

Terumah

"Contribution"

Exodus 25:1 - 27:19

Katan Aleph



In This Edition:

19.2 - Blueprints for the Mishkan Coverings and Structure
Exodus 25:8; 26:1-33, 36-37; 36:8-38



Table of Contents

Parsha Pearls is a comprehensive resource that allows for complete customization by the parent. We understand that if you were to strive to accomplish all aspects of each lesson in one day it would be unrealistic and also overload for the child. It is our intention that this be used 'a la carte' so that it suits your specific needs. Our site caters to printing only the pieces you choose.

This page will provide quick links to get to the portion of the document for which you are looking. When you hover over the title a finger will appear. Click on it and you will be taken directly to that page.

If you are new to Parsha Pearls, we have created an [Introduction](#) document outlining how to use our lessons, as well as a [Scriptural Inspiration](#) document, which explains our titles and the Scriptural inspiration for them. We pray that Parsha Pearls blesses your home and that your children will grow to love the Word and to never depart from keeping Torah. As always, feel free to email us at parshapearls@mtoi.org if you have any questions.

Gem Seeking (The Main Lesson)	3
➤ Little Gems Story (Story for Younger Children)	3
➤ Little Gems Story Characters	6
Counting What You Gained (Worksheets)	14
➤ Storing Up Treasure in My Heart (Memory Verse)	14
➤ Seeking Treasure (Questions from the Parsha)	16
➤ Word Search	17
➤ Maze	18
Precious Possessions (Arts & Crafts)	19
➤ Craft	19
➤ Coloring Page	20
Sweetness of Torah	21
➤ Sweet Sounds of Torah (Song Corresponding to the Parsha)	21
➤ Sweet Taste of Torah (Snack Corresponding to the Parsha)	22
Next Week's Treasure Hunt (Looking Ahead to Next Week's Parsha)	23



Gem Seeking

LITTLE GEMS STORY

Parent/Teacher Preparation:

Please see the [Instructions for the Little Gems Story](#) on the YMTOI website. This will help you to understand how to prepare for the story.

Blueprints for the Mishkan Coverings and Structure

Shalom, children! Today we find Mosheh still at the top of Mount Sinai, receiving more instructions from Yahweh. **(Place Mosheh and mountain on board.)** Remember that in the last parsha, he was given the instructions for making the furniture pieces - the ark of the Witness, the table of showbread, the 7-branch lampstand as well as the altar of incense. **(Place mishkan furnishings on board.)**

We wondered where those furniture pieces were going to go, didn't we? I think now Yahweh is going to tell Mosheh just how to make the home where He wants those pieces to go.

Yahweh began with the way He wanted His Dwelling Place to be covered. The wilderness is a harsh place, so He chose 4 layers of different materials for the tent's roof. Today the curtains in our houses are made in factories on machines, but back then you had to be very talented at hand-weaving these fabrics on a wooden loom. **(Place loom on board.)**

For the first layer, Yahweh wanted beautiful curtains to be made by skilled weavers. **(Place first covering on board and point to items as you read about it.)** Panels must be made of woven linen, plus material in 3 royal colors: red, blue, and purple. **(Point to woman weaving on loom.)** Remember we talked about kerubim in our last parsha? Do you remember which piece of furniture they were on? **(Give children an opportunity to answer but give answer of lid of atonement if they can't remember.)** Well Yahweh wanted kerubim to also be embroidered onto the linen of the first curtain.

(Place second covering on board.) The next layer of the covering was to be made of goats' hair, which can be spun into yarn and woven just like wool. **(Place third covering on board.)** The third covering was made of rams' skins which had been dyed red. Have you ever snuggled up on a sheepskin rug? A ram's hide would be quite large, and probably woolly, too. Wool has a special oil in it called lanolin, which would be perfect for helping to keep out rain and dew. **(Place fourth covering on board.)** Finally, the fourth covering was placed on top. It would have to be long-lasting to protect the Dwelling Place from the harsh wilderness, so Yahweh chose to have it made of fine leather. We aren't told what type of animal was used to make it. Some people claim it was badger skins. Others say it was manatees also known as sea cows but it could have also been cowhide, which is very tough, and can be rubbed to a beautiful finish.



Now we know about the coverings on top, but what will they rest on? The sides, right? So, Yahweh told Mosheh to make the sides out of wooden boards, but not just any wooden boards. **(Place acacia board on board.)** They had to be cut from acacia wood, which is a small, gnarly tree that grew all over the wilderness. **(Place acacia tree on board.)** Acacia wood is so hard that it can't be attacked by insects. **(Place tenons and sockets on board and point to each piece as you read about it.)** Each board was designed with tenons along the bottom, so they could fit onto silver sockets to form a single wall. But just imagine; Yahweh wanted none of the acacia wood showing! No, it all had to be overlaid with thin sheets of pure gold. **(Remove acacia board and place gold board on board.)** He was also to make long bars from gold-covered acacia wood and place them inside the rings all along the walls, to make sure they would stand nice and firm. **(Place boards with rings and bars on board and point to items.)**

Yahweh wanted the Dwelling Place to have 20 boards on the north and south sides. **(Place north/south side on board. Have children count boards on north and south side.)** Notice that there were 5 bars on those walls, 4 shorter and 1 very long bar in the middle that passed through the length of the wall. On the west side which was the back of the Dwelling Place, Yahweh wanted 8 boards. **(Place west side on board. Explain that the end boards were 2 boards thick making a total of 8 boards.)**

Whether you were looking from outside or inside, you would see gleaming golden walls, set in silver sockets. **(Place mishkan frame on board.)**

Now, who remembers the first covering that went over the top? It was the one that was woven with the 3 royal colors and showing figures of kerubim, right? **(Point to first covering.)** Every time the priests lifted their eyes, they would see that ceiling made of colorful woven material showing those heavenly beings. And now Yahweh wanted 2 hanging veils for the Dwelling Place, made to look much like the first covering.

The inner veil would hang down from 4 tall columns of acacia wood covered with gold set in silver sockets. **(Place inner veil on board and point to items as you read about it.)** These columns were made in the same way as the boards - acacia wood covered with pure gold. The veil was to be of fine, woven linen, in the 3 royal colors: red, blue and purple. Can you guess what was embroidered on this veil? If you said kerubim, you're right! The beautiful inner veil was meant to form a divider to separate the Set-apart Place from the Most Set-apart Place.

Once a year the high priest would also be allowed in the Most Set-apart Place, on the Day of Atonement. The Most Set-apart Place was to be perfectly square, and behind its veil they were to place the ark of the Witness, the gold-covered box with its lid of atonement that was crafted with 2 golden kerubim. **(Place ark of the Witness on board.)** Inside the ark of the Witness, Mosheh was to place the 2 stone tablets that Yahweh gave him on the mountain, of the agreement He had made with His people Yisra'el. **(Place tablets on board.)**



Now, there was an outer veil, too, for covering the entrance to the Dwelling Place. **(Place outer veil on board.)** This one was also hung on tall columns - 5 columns of acacia wood covered with gold set in bronze sockets. **(Point to each item.)** Again, it was made of fine woven linen, in the royal colors of red, blue and purple, except there were no kerubim on this veil.

(Remove all characters from board. Place mishkan on board.)

Even though they haven't put it all together yet, we can take a look at how beautiful it will be. **(Point to mishkan.)**

Can you imagine all the excitement of making all these special pieces for Yahweh's Dwelling Place? What a wonderful thing, to know that the Mighty One of Yisra'el was going to be living right there with His people!

Mosheh hasn't received all the blueprints yet. Yahweh will tell him about a special fence to go around His Dwelling Place. But that will have to wait until next time.

Well children, we have come to the end of our story for today. We will see you next week for another exciting Little Gems story!



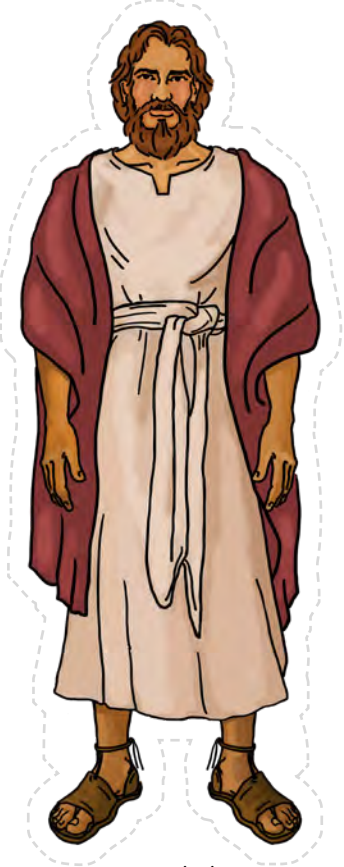

Mosheh

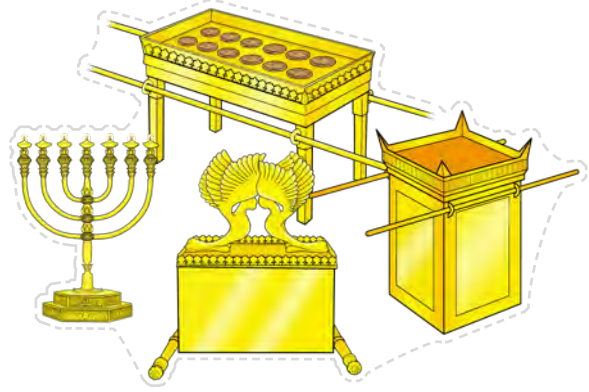

Mishkan furnishings



Ark of the Witness



Acacia tree



Loom

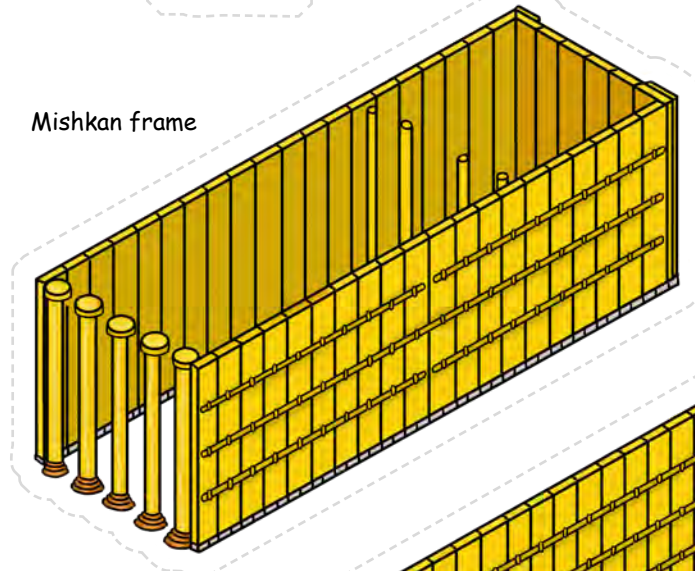

Mishkan frame

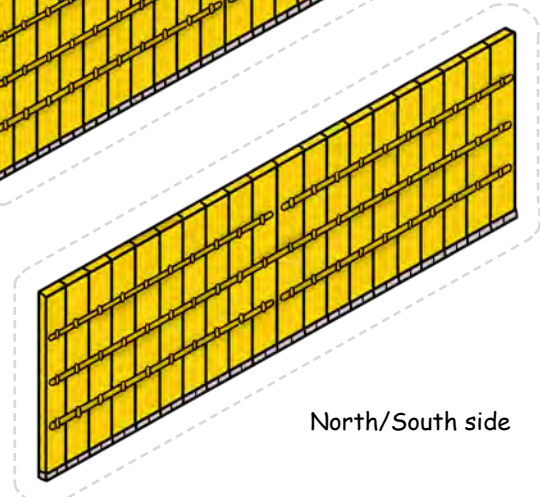

North/South side



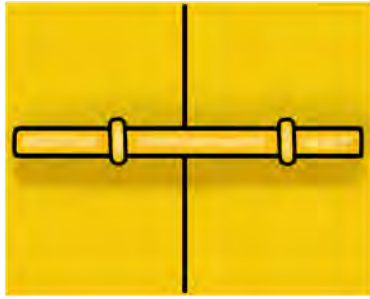

Boards with rings and bars

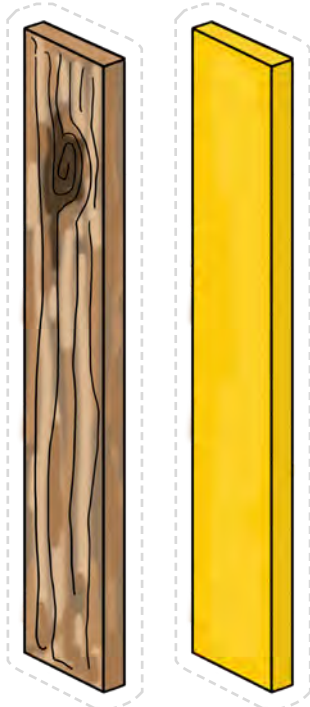

Acacia board Gold board

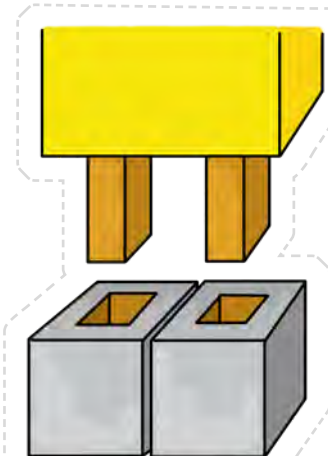

Tenons and sockets

Mountain



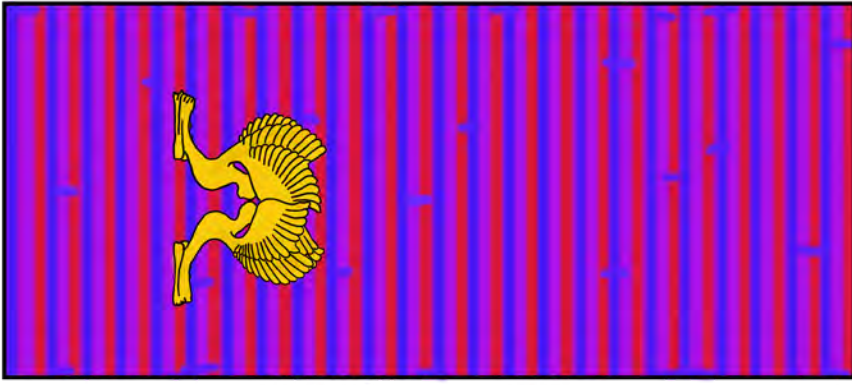

First covering

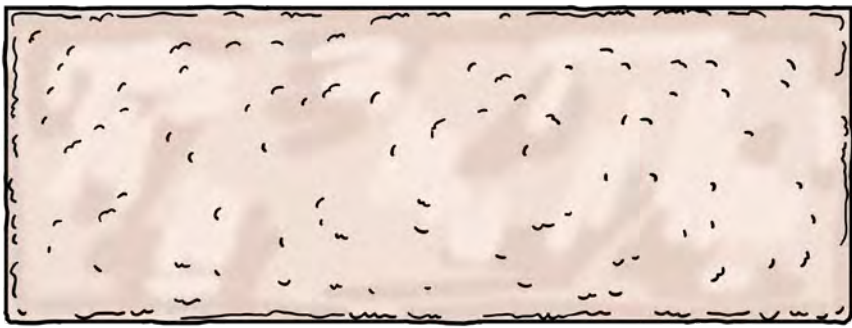

Second covering

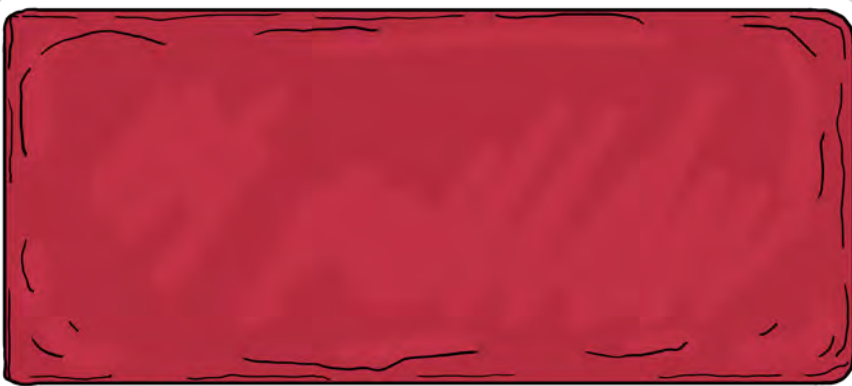

Third covering



Fourth covering

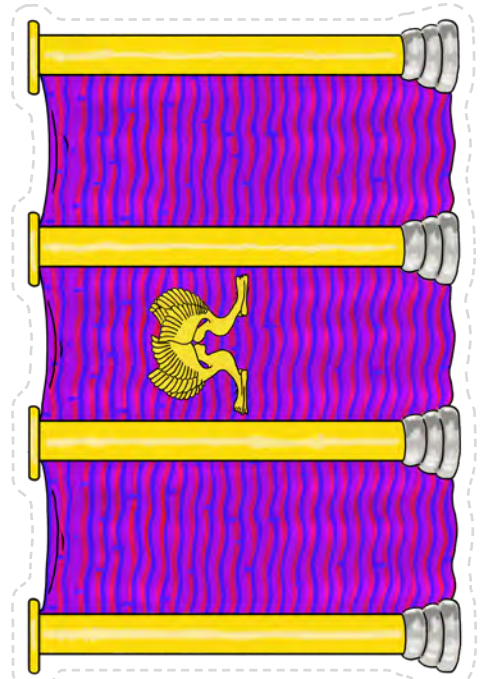

Inner veil

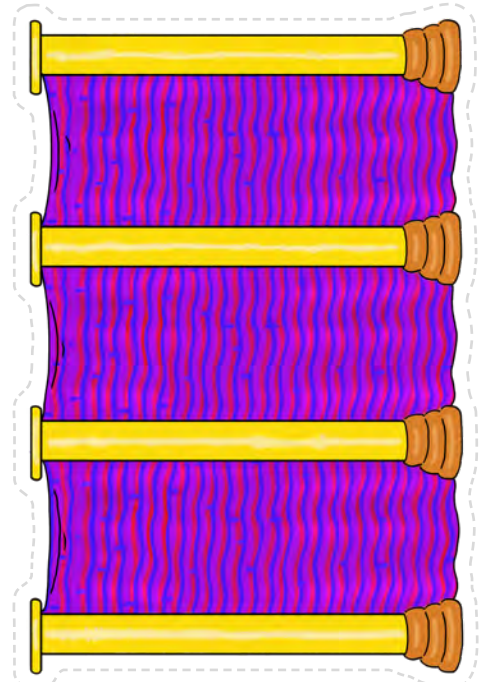

Outer veil



Tablets

Mishkan

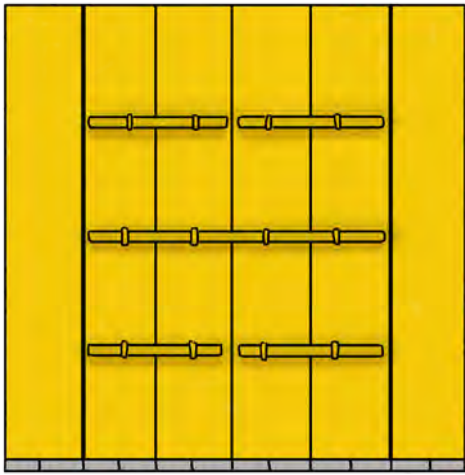

West side

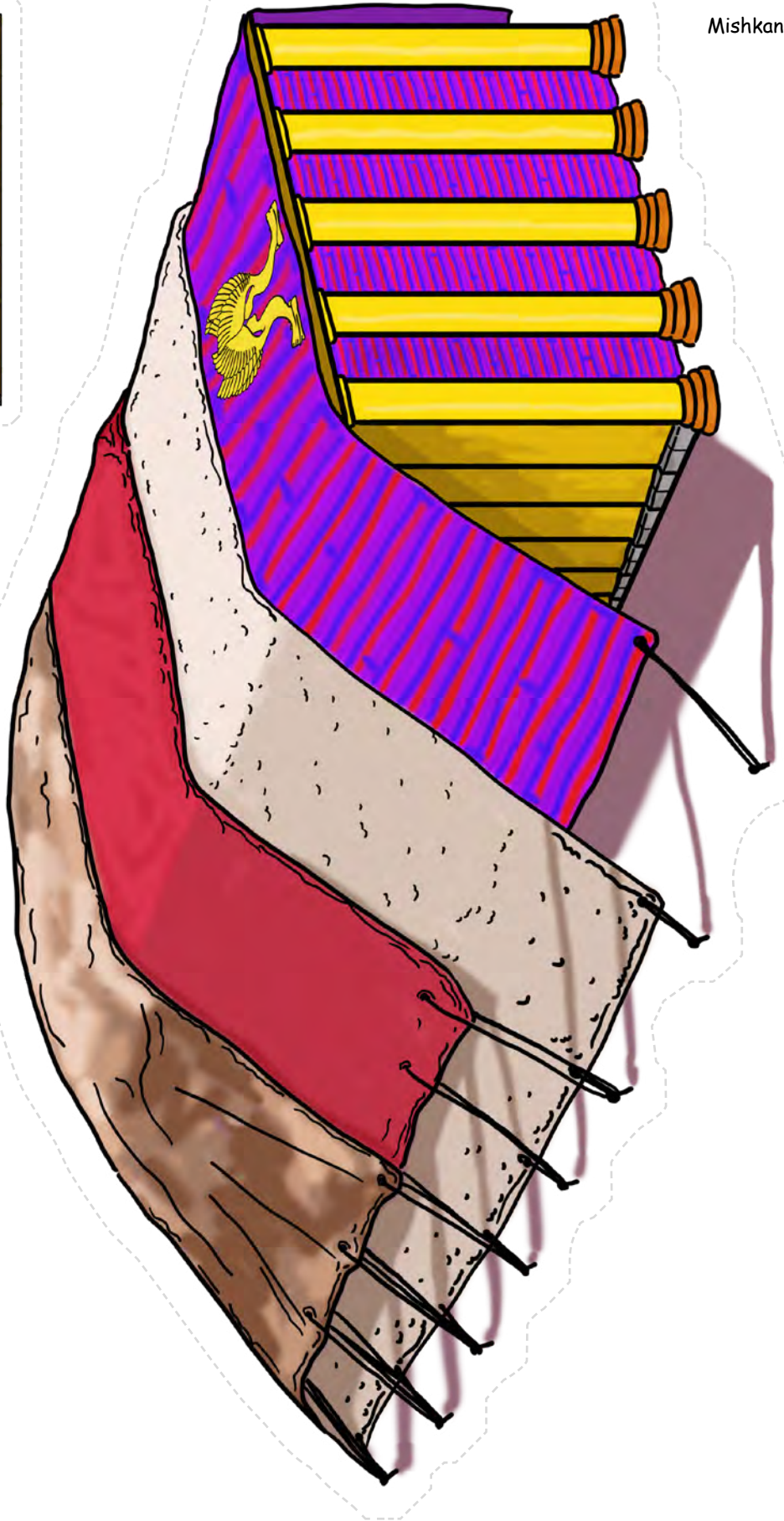



Mosheh

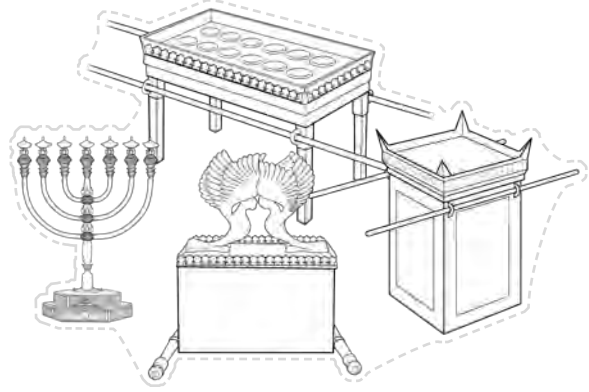

Mishkan furnishings

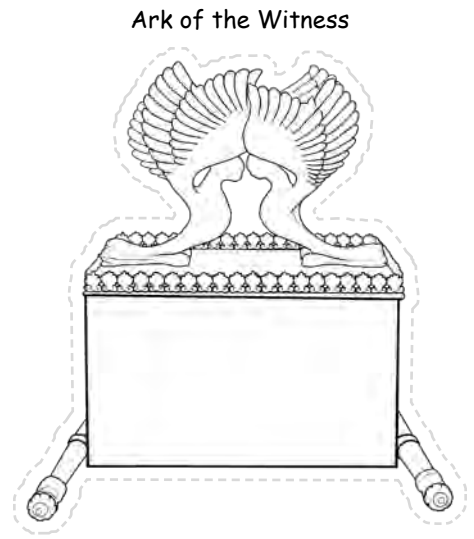

Ark of the Witness

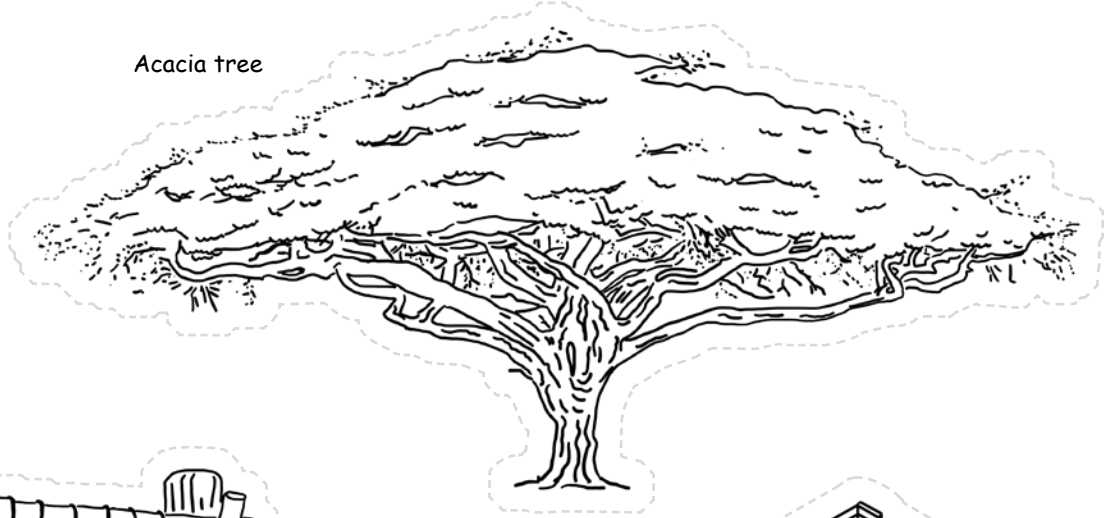

Acacia tree

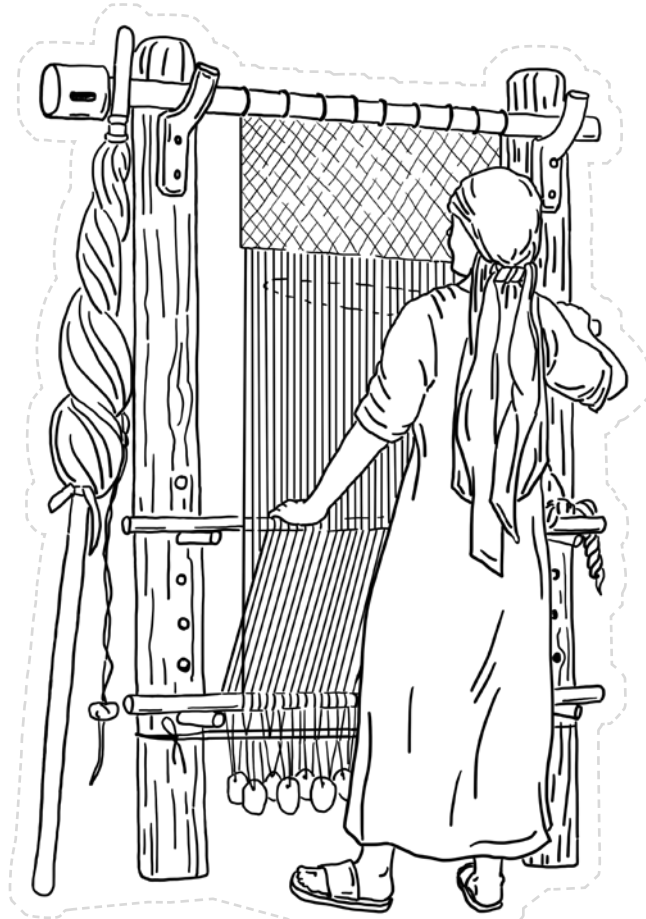

Loom

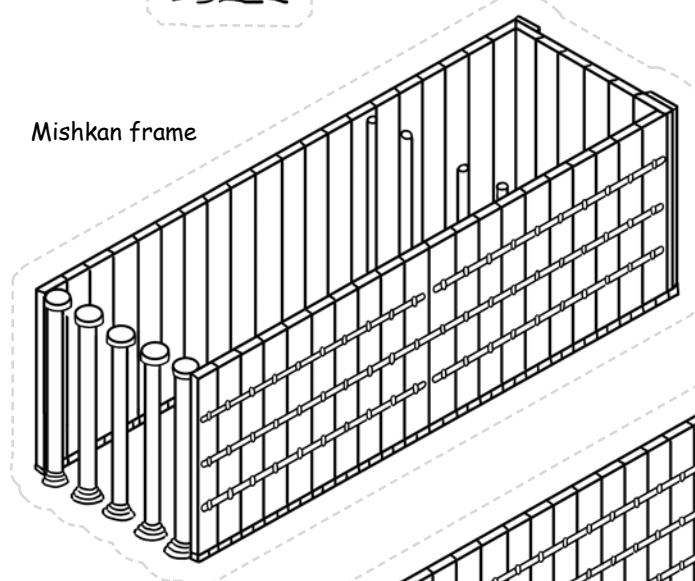

Mishkan frame

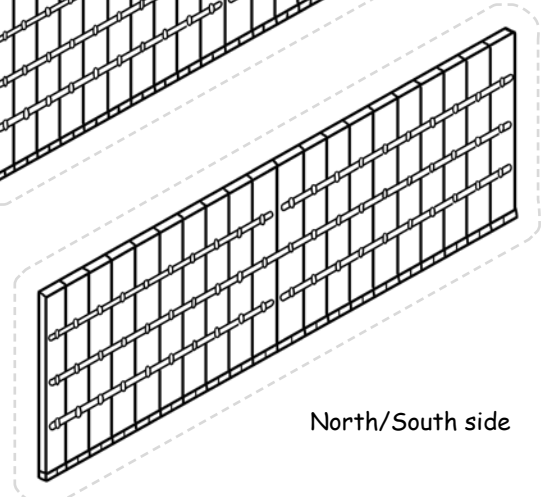

North/South side



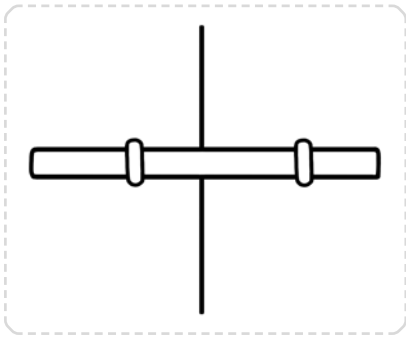

Boards with rings and bars

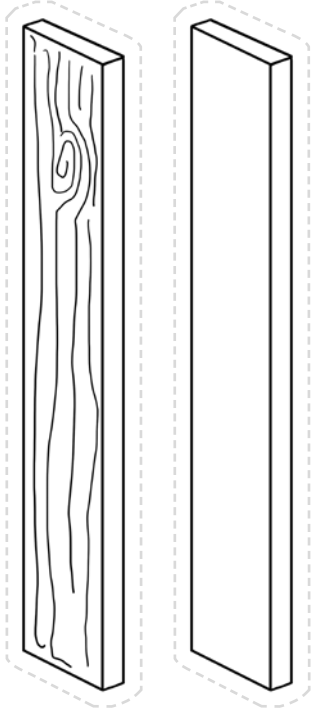

Acacia board Gold board

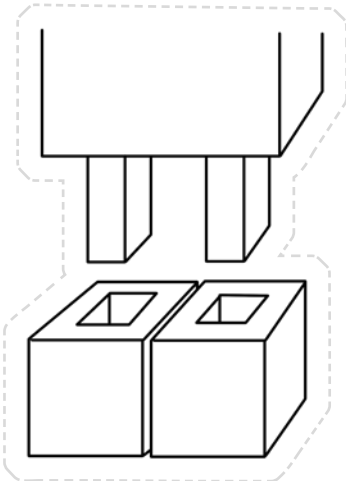

Tenons and sockets

Mountain



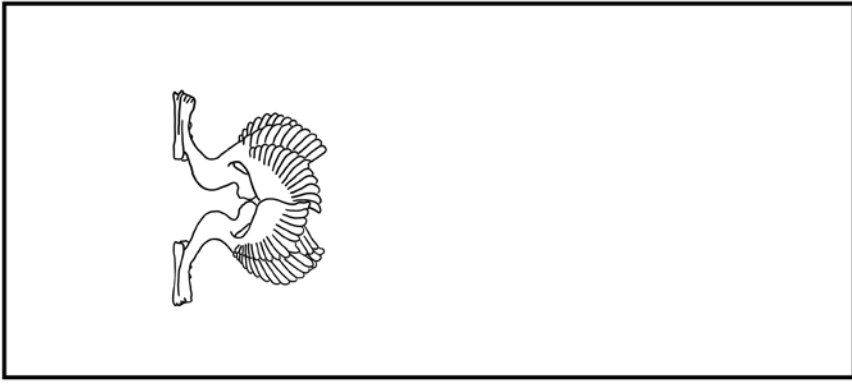

First covering

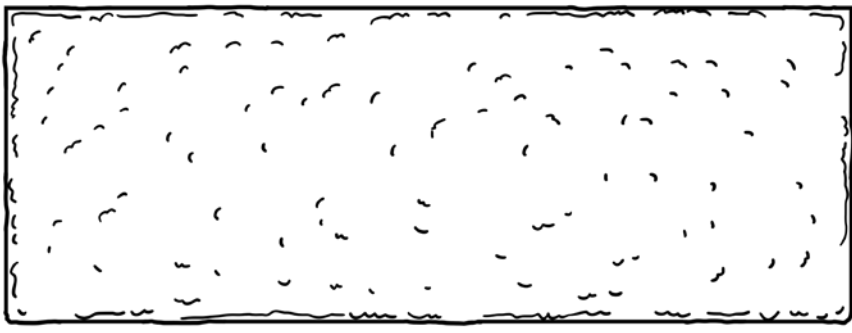

Second covering

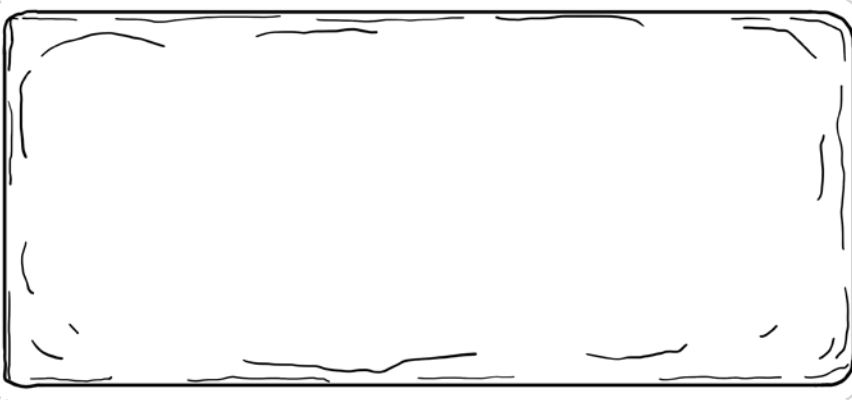

Third covering

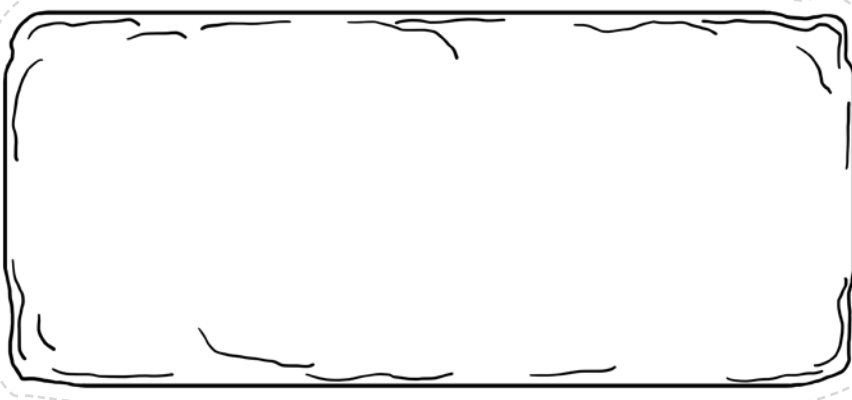

Fourth covering

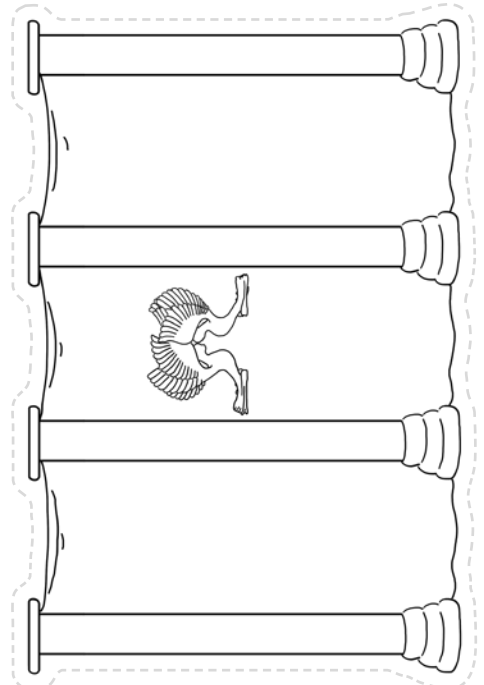

Inner veil

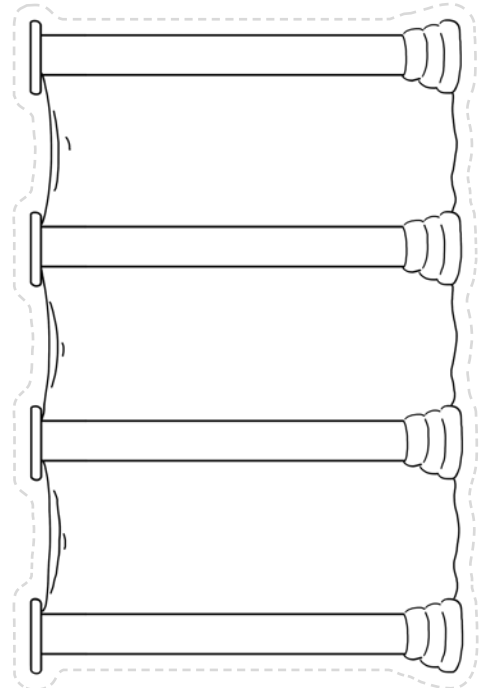

Outer veil



Tablets



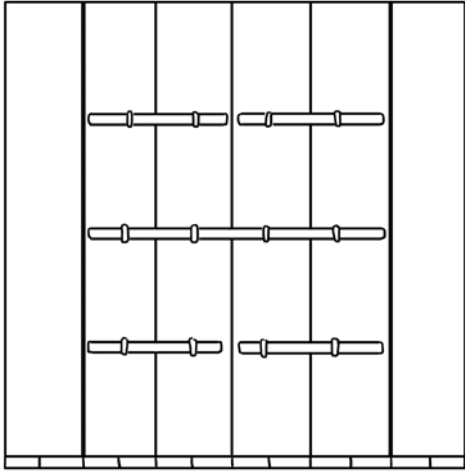

West side

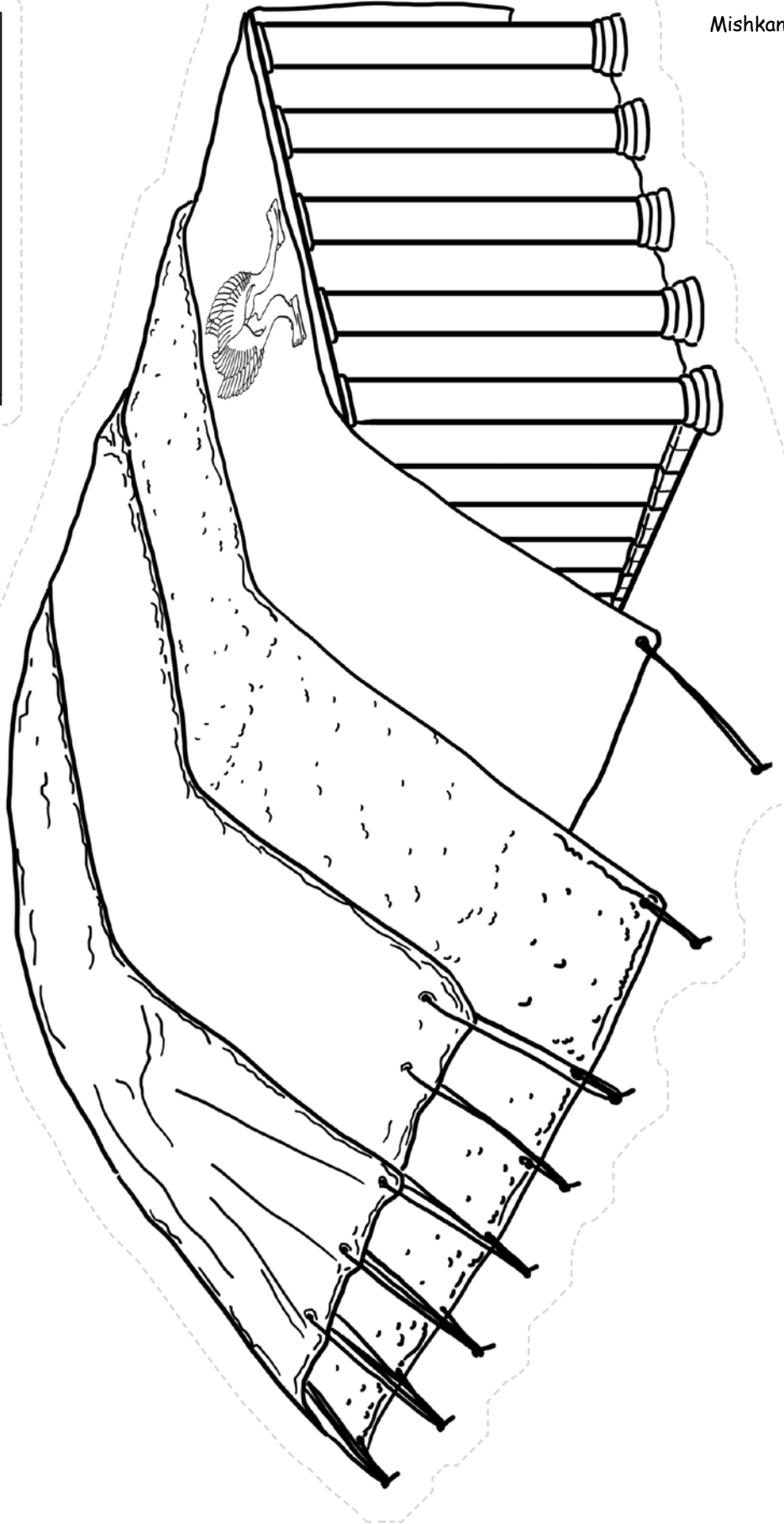

Counting What You Gained

This next section is intended to be reinforcement of the lessons learned during this parsha. Choose the activities that best fit your child.

STORING UP TREASURE IN MY HEART

The Katan Aleph memory verse for this Torah portion is Exodus 26:30. If they have not already done so, begin to help them to memorize the verse. Be creative and try acting it out, or putting it to music.

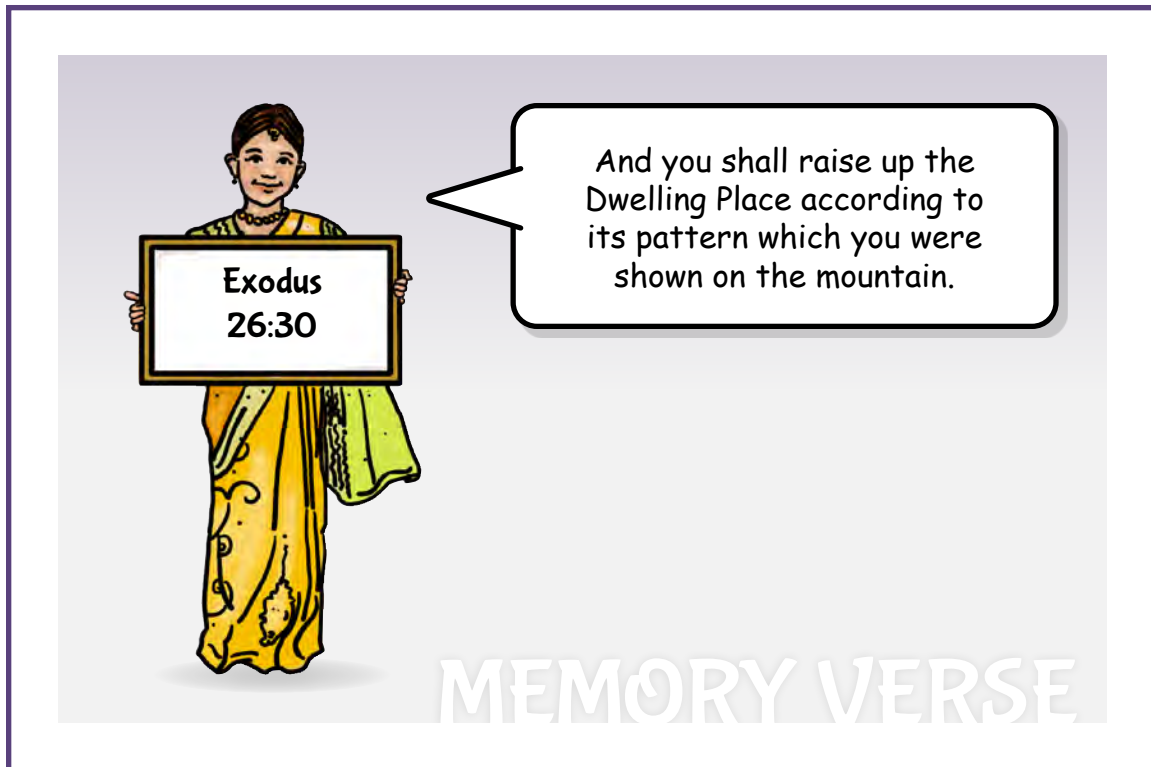

Exodus
26:30

And you shall raise up the Dwelling Place according to its pattern which you were shown on the mountain.

MEMORY VERSE

SEEKING TREASURE

Circle the correct choices.

1. What special image was on the first covering and inner veil? (26:1, 31)

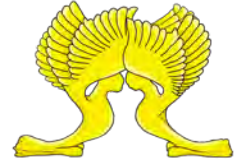

2. What was the first covering? (26:1)

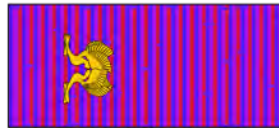

3. What was the second covering? (26:7)

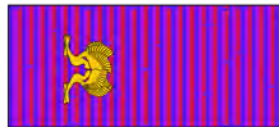

4. What was the third covering? (26:14)

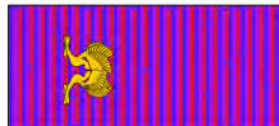

5. What was the fourth covering? (26:14)

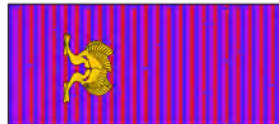

6. Which furniture piece was placed inside the Most Set-apart Place? (26:33)

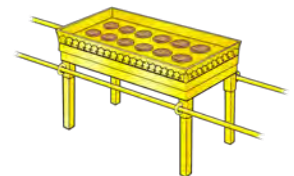
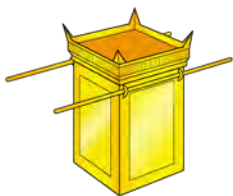

WORD SEARCH

Search for the hidden words from this week's parsha.



LINEN
GOATS
RAMS
LEATHER
BLUE
PURPLE
SCARLET



MAZE

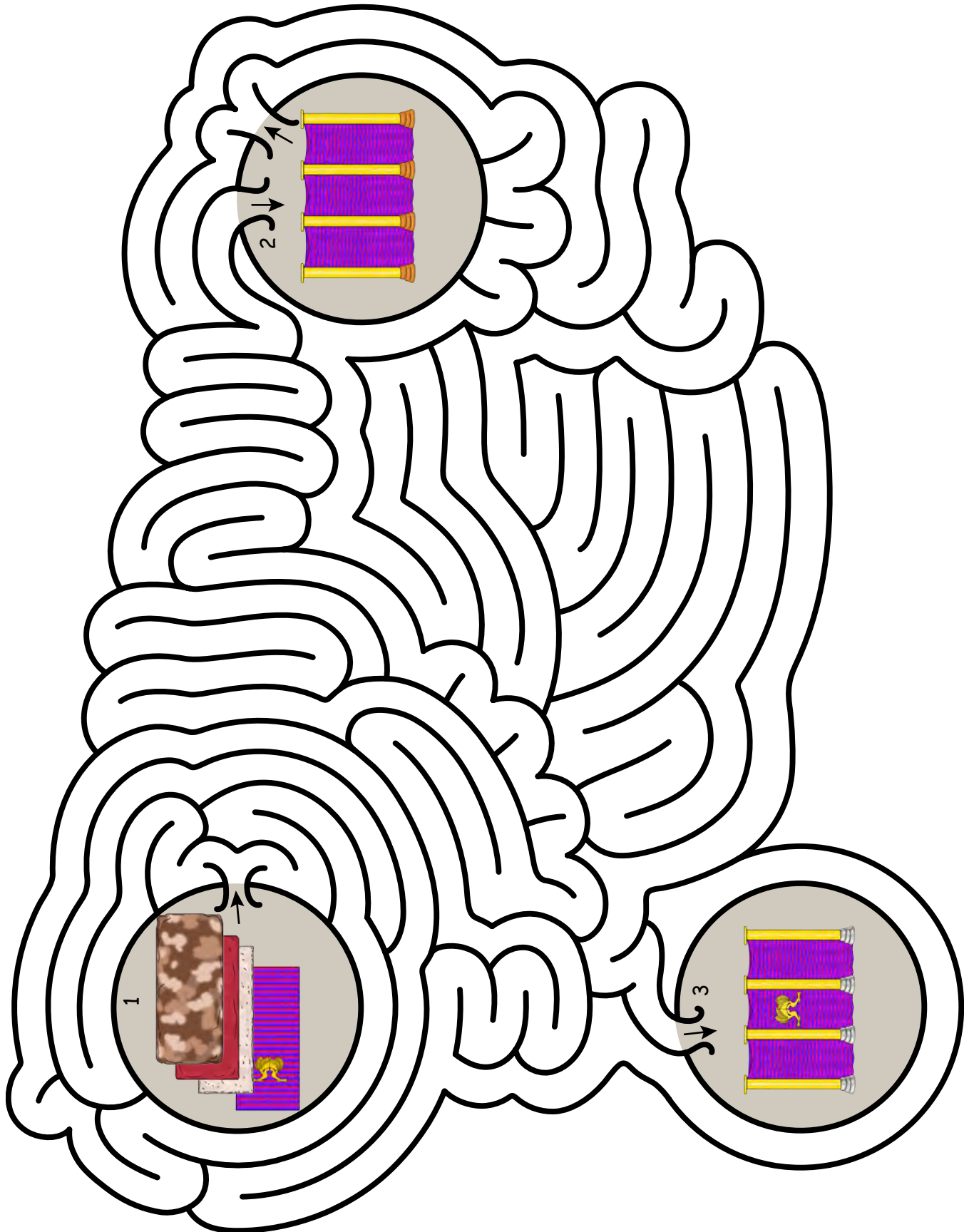

Precious Possessions

CRAFT

Materials:

- Handkerchief - white
- Permanent markers - blue, purple, red
- Rubbing alcohol
- Spray bottle
- Plastic tablecloth

Parent/Teacher Preparation:

- This project will bleed through the fabric until it is dry, so we highly recommend protecting tables with a plastic tablecloth before doing this craft.
- Pour alcohol into spray bottle. No need to dilute.

Blue, Purple & Scarlet Material

Exodus 26:1-6, 31, 36; 36:8-13, 35, 37



Instructions for the Craft:

- Using the blue, purple and red permanent markers, make straight lines on the 4" x 3" cotton piece covering it completely. (P1)
- Spray the alcohol on the drawn areas of the handkerchief a little at a time - do not saturate the cloth. (P2) A blending action will begin to take place. (P3) We recommend you work in quadrants as you do this.
- Set aside to dry.

You now have a representation of the 3 fabric colors for the first covering, the inner veil and the outer veil of the mishkan.



P1

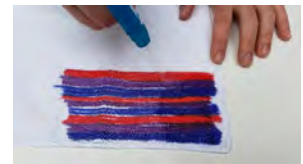

P2



P3

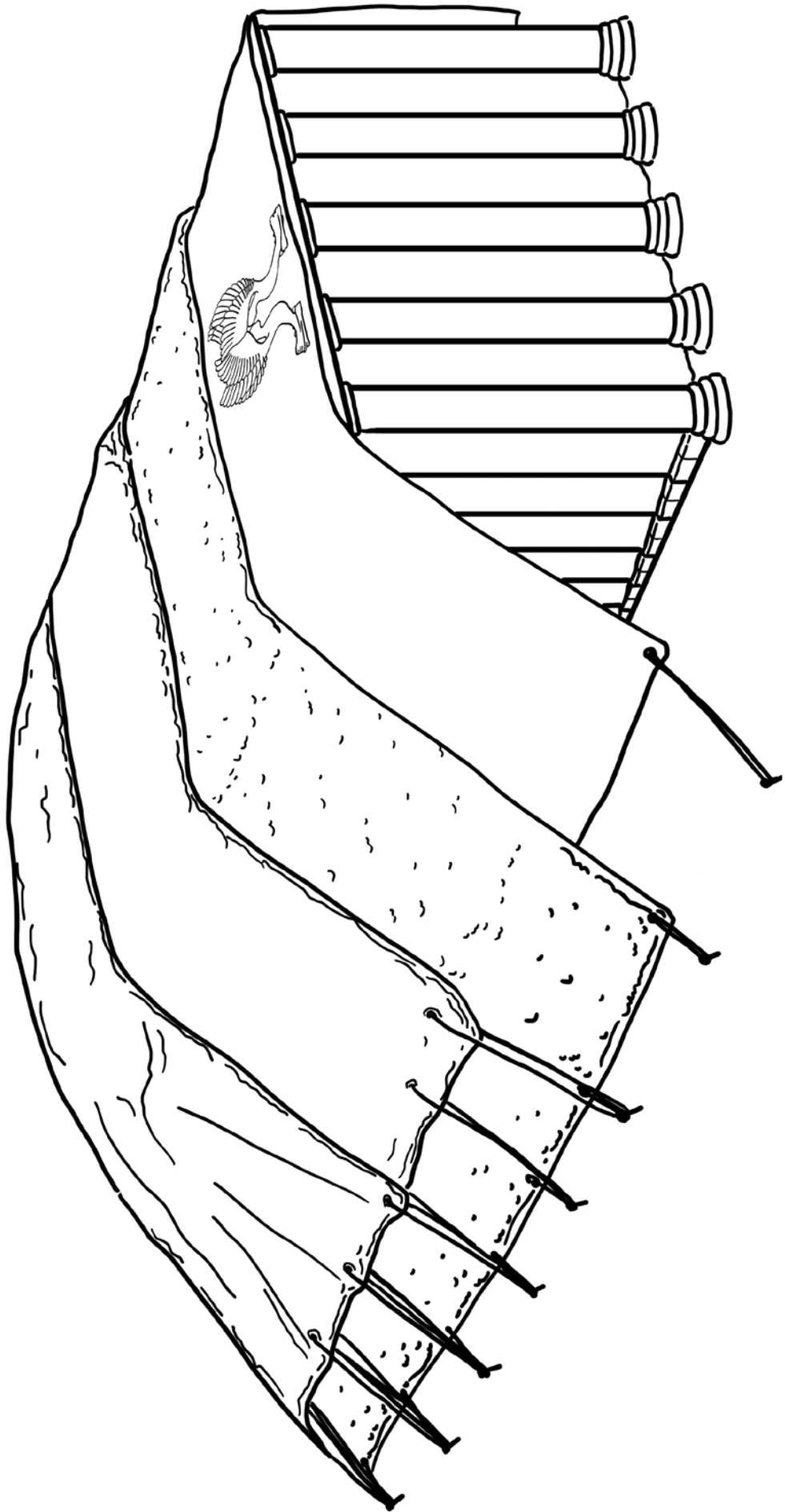

Sweetness of Torah

SWEET SOUNDS OF TORAH

(Sing Praises to His Name)

Here is the link for this song:

https://www.podomatic.com/podcasts/steveberkson/episodes/2024-02-09T06_00_00-08_00

Follow the Pattern

For when you raise up the Dwelling Place

Do it as I say

For when you raise up the Dwelling Place

Do it as I say

Follow the pattern

Follow the pattern

Which you were shown on the mountain

Follow the pattern

Follow the pattern

Which you were shown on the mountain

For when you raise up the Dwelling Place

Do it as I say

For when you raise up the Dwelling Place

Do it as I say



SWEET TASTE OF TORAH

This snack relates to this week's parsha. Please take these as suggestions and make necessary changes based on your individual dietary needs.

Mishkan/Dwelling Place

Exodus 26:15



Ingredients:

- *Graham* crackers - 7-8 (to give strength to pretzel sticks)
- Pretzel sticks - approx. 57 (represents boards & pillars)
- Fruit leather or *Fruit Roll-ups* (represents coverings/veil)
- Chocolate frosting (use as adhesive)
- Optional: brown sugar (represents ground)

Instructions:

Place *Graham* crackers in a stack in the center of a plate or aluminum foil in the shape of a rectangle. Use the chocolate frosting to go around the edge of the stack of *Graham* crackers - you may need to pipe some to ensure that you have a thick layer of frosting. Place pretzel sticks into the frosting and arrange in a pattern to create a rectangle leaving room for an opening where the first veil would be. Place 4 different colored fruit leathers/*Fruit Roll-ups* over the sticks to represent the coverings. You can also use a fruit leather to create the first veil. Optional: sprinkle brown sugar on the plate or aluminum foil to represent the ground.

Next Week's Treasure Hunt

Next Week's Torah Portion

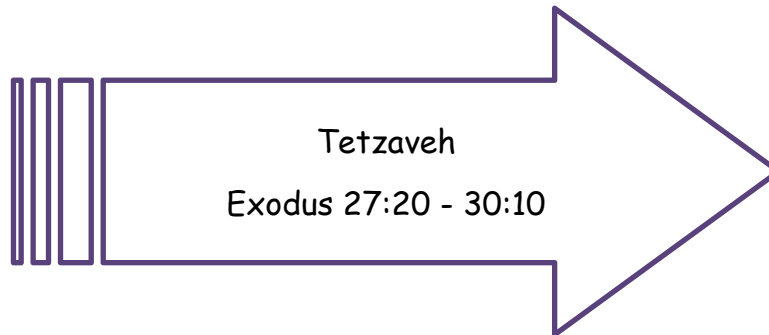

Suggested Reading Schedule

Monday:	Ex. 27:20-28:30	Oil for the lamp; Instructions for making the set-apart garments
Tuesday:	Ex. 28:31-43	Instructions for making the set-apart garments
Wednesday:	Ex. 29:1-28	Instruction for the ordination of the priests
Thursday:	Ex. 29:29-46	Instruction for the ordination of the priests
Friday:	Ex. 30:1-10	Specifications for the altar of incense