

Parsha Pearls

Ki Tisa

"When You Take Up"

Exodus 30:11 - 34:35
Katan Aleph



In This Edition:

21.2 - Blueprints for the Courtyard
Exodus 27:1-19; 30:17-21; 38:1-20; 40:6-7



Table of Contents

Parsha Pearls is a comprehensive resource that allows for complete customization by the parent. We understand that if you were to strive to accomplish all aspects of each lesson in one day it would be unrealistic and also overload for the child. It is our intention that this be used 'a la carte' so that it suits your specific needs. Our site caters to printing only the pieces you choose.

This page will provide quick links to get to the portion of the document for which you are looking. When you hover over the title a finger will appear. Click on it and you will be taken directly to that page.

If you are new to Parsha Pearls, we have created an [Introduction](#) document outlining how to use our lessons, as well as a [Scriptural Inspiration](#) document, which explains our titles and the Scriptural inspiration for them. We pray that Parsha Pearls blesses your home and that your children will grow to love the Word and to never depart from keeping Torah. As always, feel free to email us at parshapearls@mtoi.org if you have any questions.

Gem Seeking (The Main Lesson)	3
➤ Little Gems Story (Story for Younger Children)	3
➤ Little Gems Story Characters	5
Counting What You Gained (Worksheets)	11
➤ Storing Up Treasure in My Heart (Memory Verse)	11
➤ Seeking Treasure (Questions from the Parsha)	13
➤ Word Search	14
➤ Maze	15
Precious Possessions (Arts & Crafts)	16
➤ Craft	16
➤ Coloring Page	17
Sweetness of Torah	18
➤ Sweet Sounds of Torah (Song Corresponding to the Parsha)	18
➤ Sweet Taste of Torah (Snack Corresponding to the Parsha)	19
Next Week's Treasure Hunt (Looking Ahead to Next Week's Parsha)	20



Gem Seeking

LITTLE GEMS STORY

Parent/Teacher Preparation:

Please see the [Instructions for the Little Gems Story](#) on the YMTOI website. This will help you to understand how to prepare for the story.

Blueprints for the Courtyard

Shalom, children! Our last story was all about how Yahweh commanded a special ceremony that would mark His priests as set-apart for serving Him in the Dwelling Place. But before that can be done, Mosheh must receive instructions for building the courtyard, a larger area surrounding the Dwelling Place. **(Place courtyard on board.)** Here the Yisra'elites will bring their offerings of clean animals and grains mixed with oil, so that the priests and Lewites can cook them in a very special way, just as Yahweh commanded.

Just imagine how very beautiful it will be inside the Set-apart Place! But unless you were a priest, you would never see it, because it was to be covered up and only the priests will be allowed to go in there. But the courtyard will be just outside the Dwelling Place, and it's marked off by fine linen screens all around it. **(Place screen on board.)** Yahweh told Mosheh exactly how long and how wide each screen had to be, and exactly how many screens were to be set up on each side. That wall of screens around the Dwelling Place is going to be too tall for us to see inside, but whenever we bring an offering made by fire, we will be invited into the courtyard with our animal to be offered, and will be able to see just how busy those priests had to be! **(Place priest on board.)**

Has anyone ever been camping in a tent that was held down with cords and tent pegs? **(Place tent with cords and pegs on board.)** Yahweh wants the linen screens around the courtyard to be anchored down the same way. How handsome these screens will be! Mosheh was told to have them made from finely woven linen and fastened to bronze columns by special bands and hooks made of silver. **(Place column with cord and peg on board.)** Then the columns are to be fixed to the ground by bronze pegs connected to cords that reach to the top of the columns. **(Point to cord and peg on board.)** Who remembers what kind of metal bronze is? That's right - it's copper and tin melted together. Those pegs had to be very strong. Yahweh did not want His Dwelling Place blowing all over the wilderness!

Now on the east end of the Dwelling Place, Mosheh was to leave space for a beautiful gate, where the people could enter with their offerings. **(Place east gate on board.)** It must also be woven of linen, with beautiful colors of blue, purple and scarlet on it. Wow, I'm sure none of us has ever camped in a tent like that!



Now, let's talk about how Yahweh intended to get His offerings roasted in fire. Near to the gate of the courtyard, He told Mosheh to build a big altar to hold the fire for cooking. **(Place bronze altar on board.)** Have you ever been to a barbecue, where your parents cooked chicken, or maybe hamburgers and hot dogs on a grill? **(Place grill on board.)** Well, Yahweh knew they would need a very big grill in that courtyard, because all the people would be bringing their lambs, cattle and goats to be offered to Him by fire. As we saw last week, some of the offerings must be burned completely and not eaten, in obedience to Yahweh. And just because this altar was to be placed outside the Set-apart Place, that didn't mean that Yahweh was any less careful about its measurements. Like everything else, this big grill would have to be made exactly the size Yahweh ordered, and out of His chosen materials. He ordered it to be made from planks of acacia wood, in the shape of a perfect square. **(Place acacia wood board on board.)** Then the planks would have to be completely covered in bronze. **(Place bronze board on board.)**

Wow, this bronze altar would be something to look at, won't it? But what the people won't be able to see is that it's going to be hollow inside, with a grating across the middle that Yahweh wants to be there so it can catch dripping animal fat and ashes. **(Point to grating.)** He also told Mosheh to make all kinds of long utensils out of bronze, so no one would burn their hands or get all sooty when they handled the fire, the ashes and the meat. **(Place shovel, pot, fire holder and fork utensils on board.)** Our Elohim thinks of everything, doesn't He?

Now, the altar for burnt offerings wasn't the only thing in the courtyard. Yahweh also wanted a big, round washbasin, full of gallons and gallons of water. **(Place bronze basin on board.)** Can anyone guess what this will be made of? If you guessed bronze, you're right! And this huge bowl was to sit on top of a bronze stand, so the priests could use it for washing. **(Place bronze basin on stand on board.)** In fact, they will not be allowed to make any offerings or to do any service in the Dwelling Place until they have washed both their hands and their feet in it. If they come near the Dwelling Place to serve there or come to the altar to make any animal sacrifices, they'd better be sure they have washed both their hands and their feet in it. If they got lazy and forgot, Yahweh said they must die!

You see, children, it's so important to do exactly as Yahweh commands us. Our hands represent what we do, and our feet represent our walk with Him. We want to be careful that our deeds are clean and pleasing to Him. The more we learn about His Dwelling Place, the more excited we will be about walking with Him in careful obedience, so we can each become a beautiful place for Him to live in.

Well children, we have come to the end of our story for today. We will see you next week for another exciting Little Gems story!



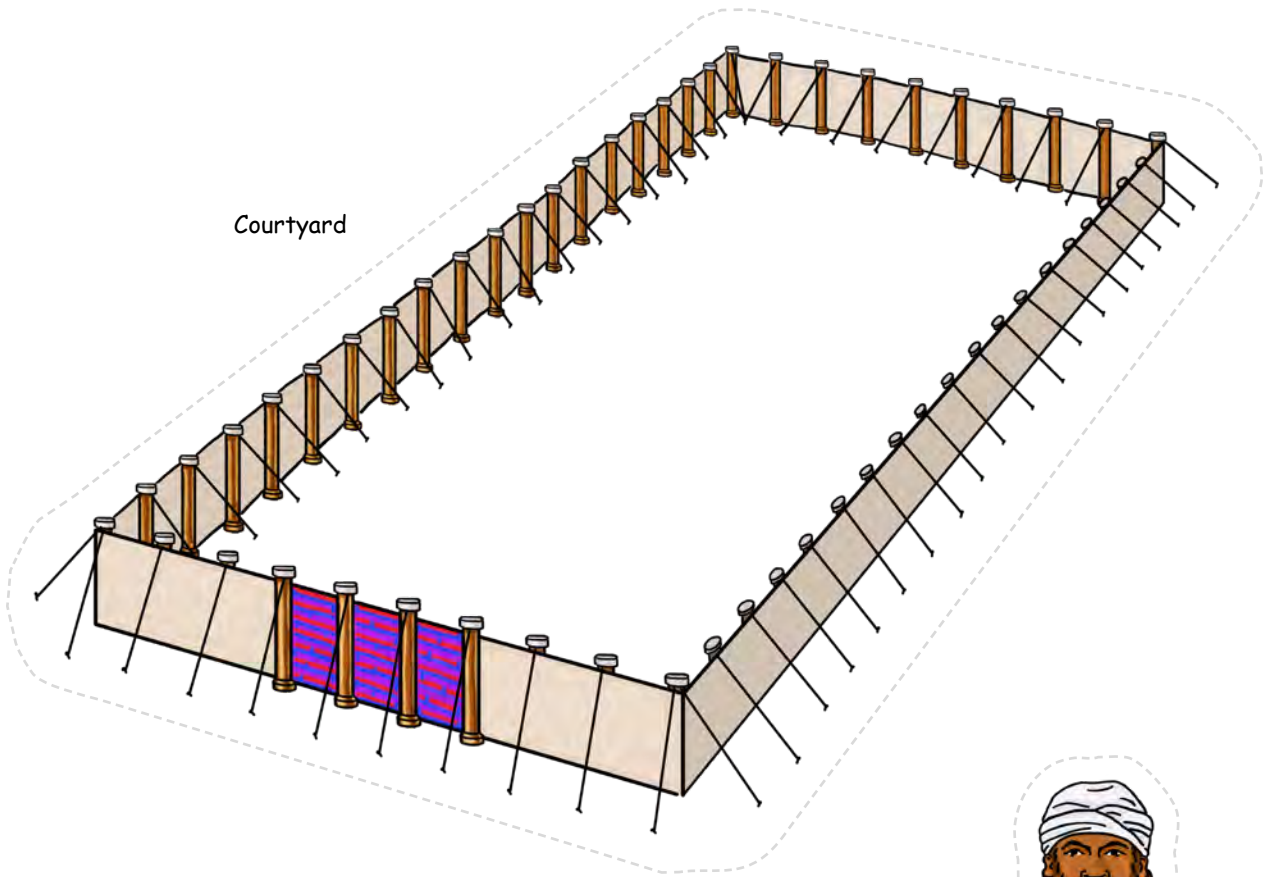

Courtyard

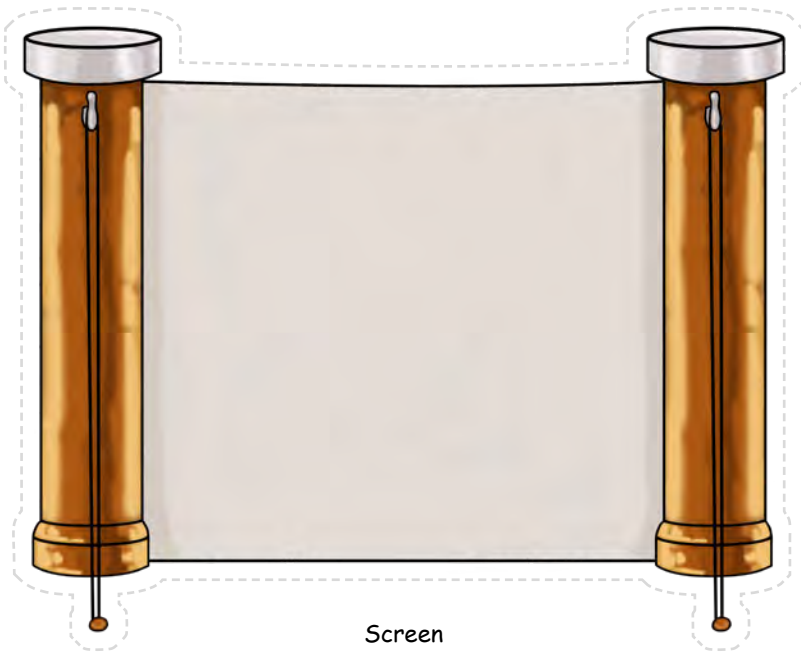

Screen



Priest

Tent with cords and pegs

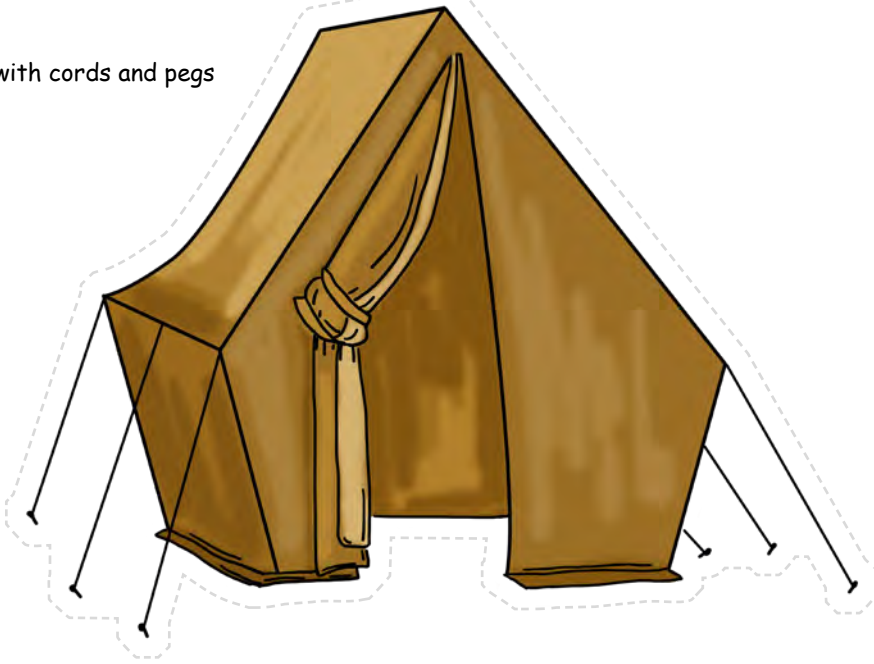

Column with cord and peg

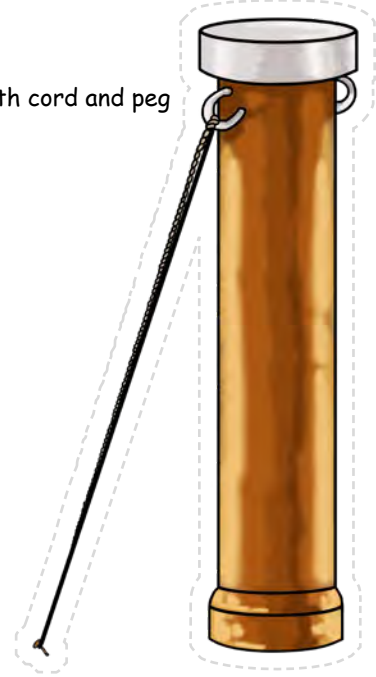

East gate

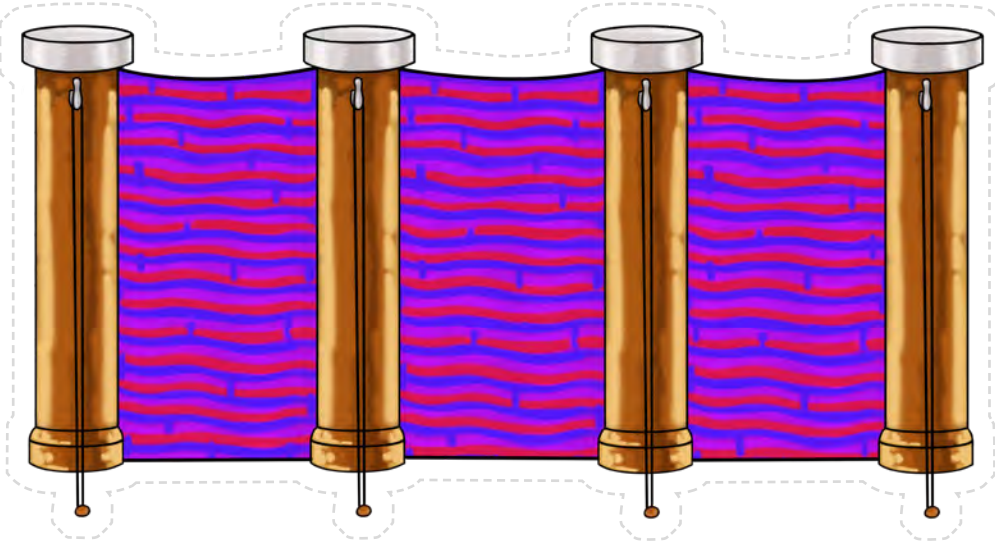

Bronze altar

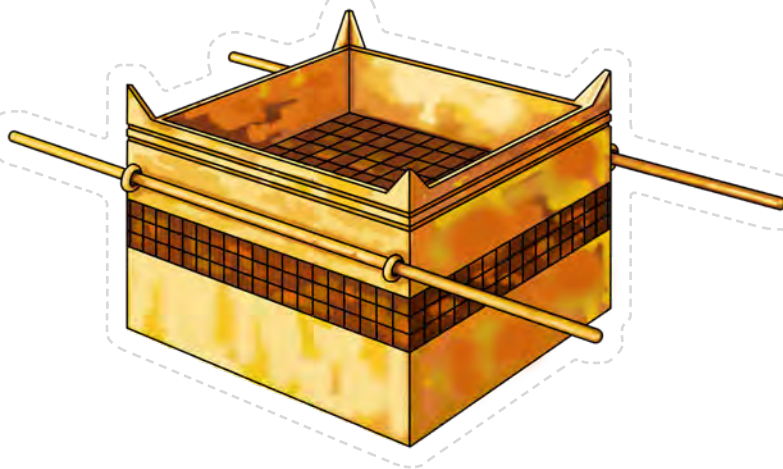

Grill





Fireholder



Fork

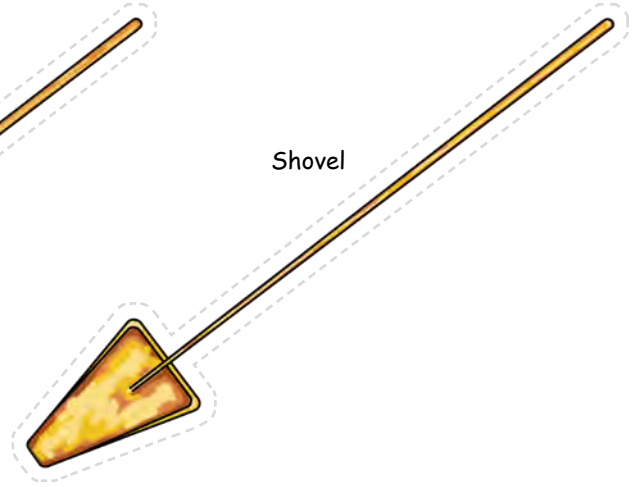

Shovel



Pot

Bronze board

Acacia board

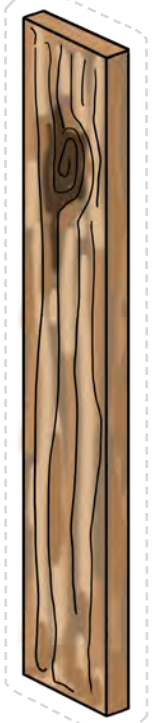

Bronze basin on stand

Bronze basin

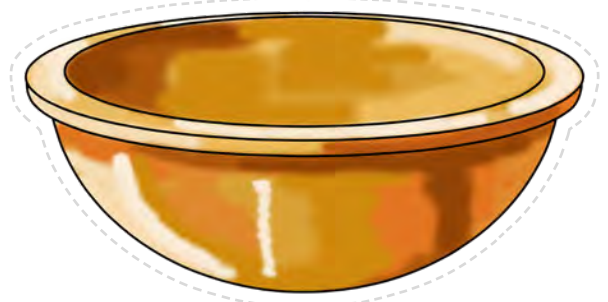

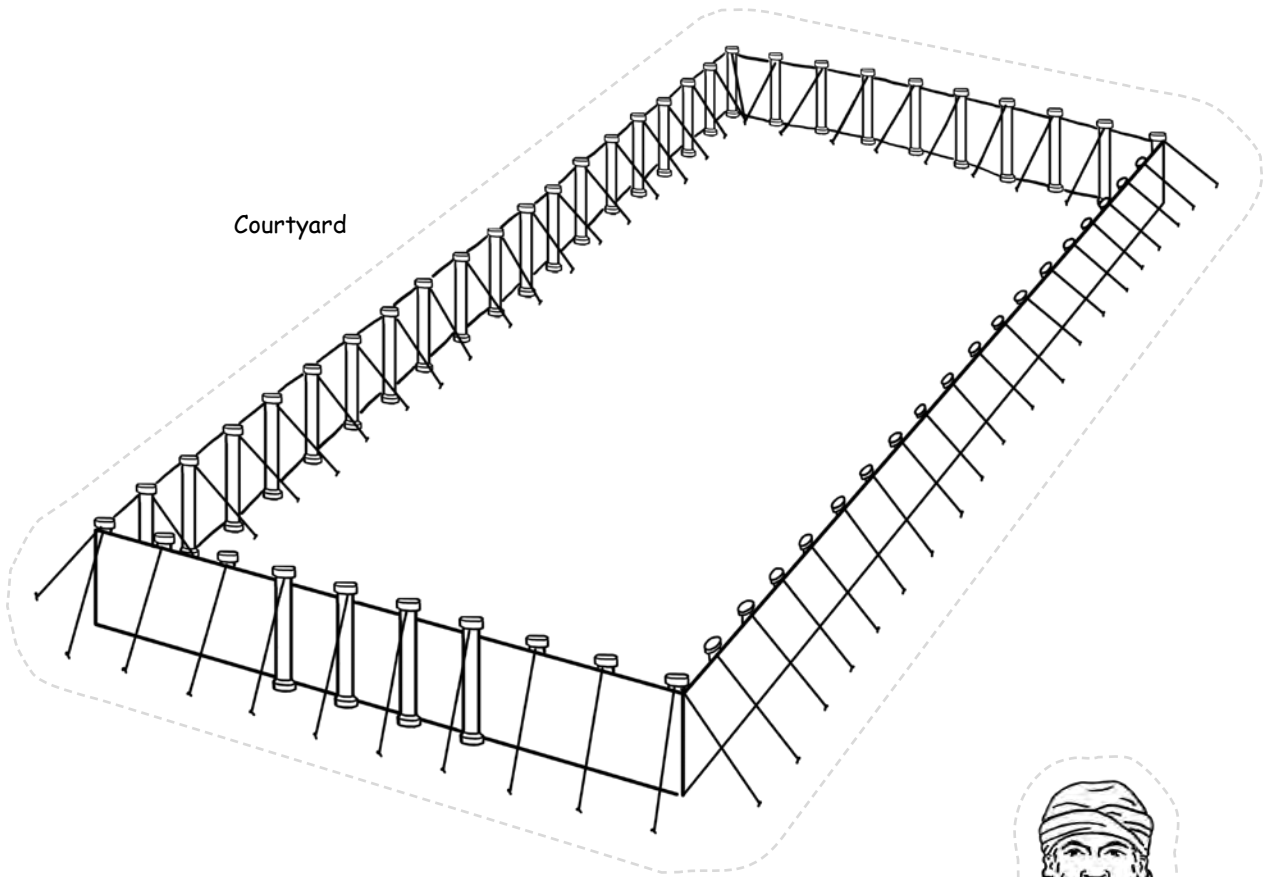

Courtyard

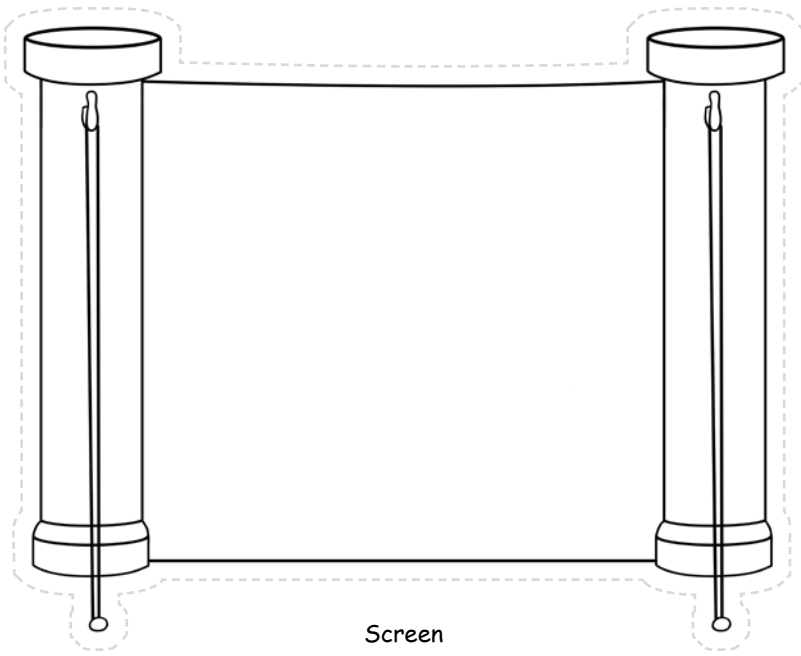

Screen

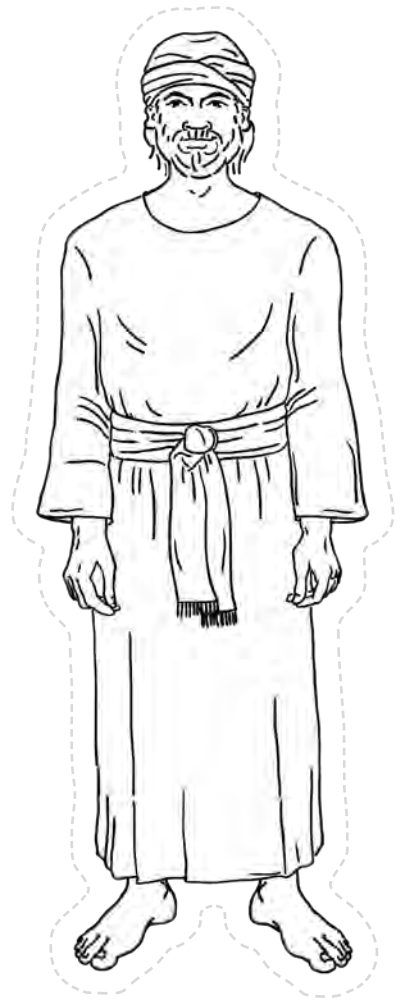

Priest



Tent with cords and pegs

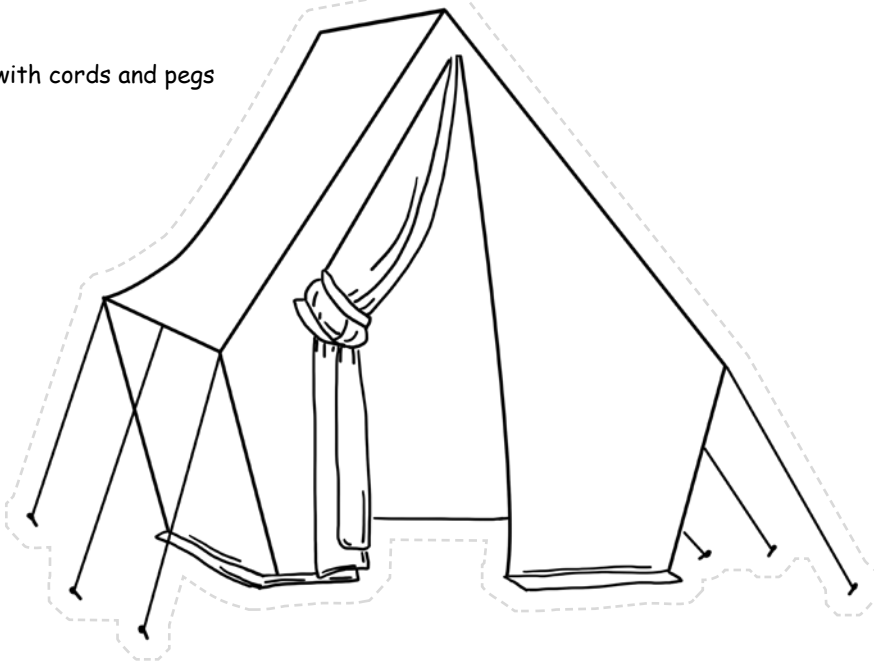

Column with cord and peg

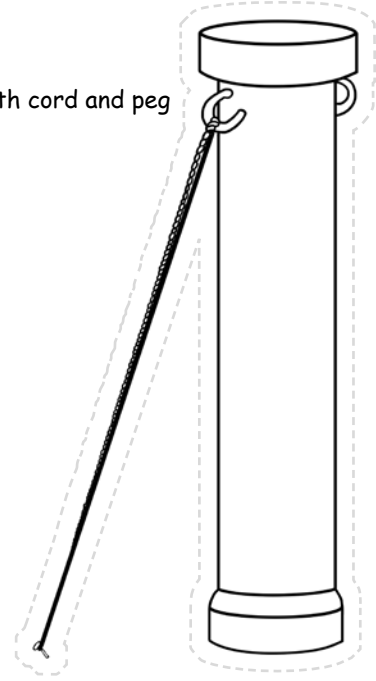

East gate

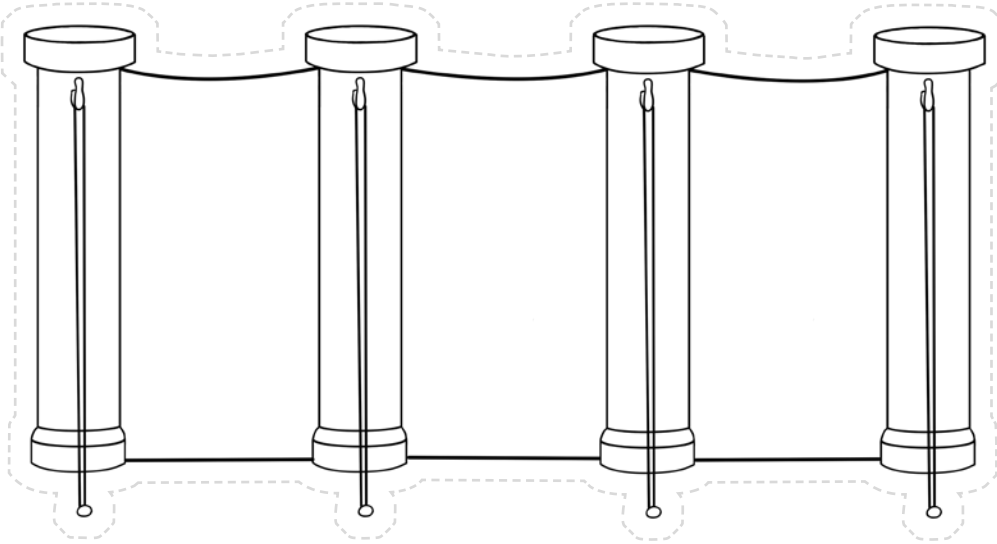

Bronze altar

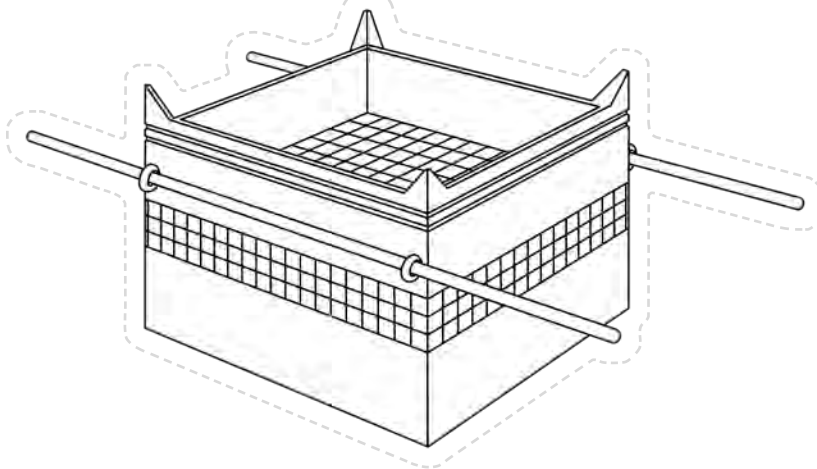

Grill

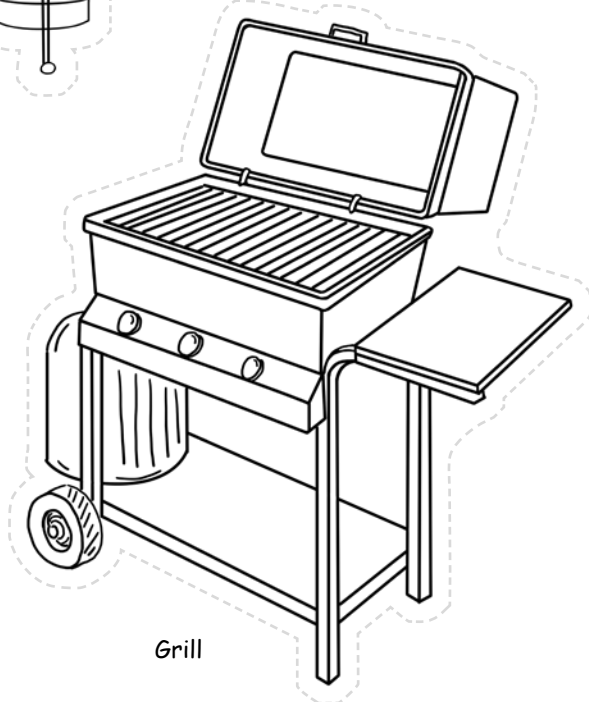

Fireholder

Fork

Shovel

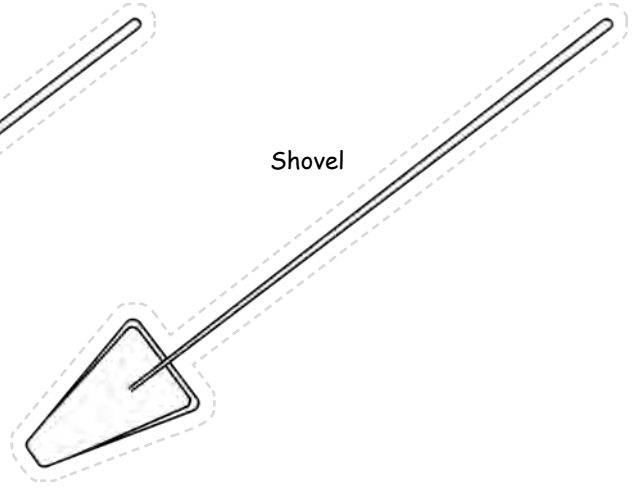
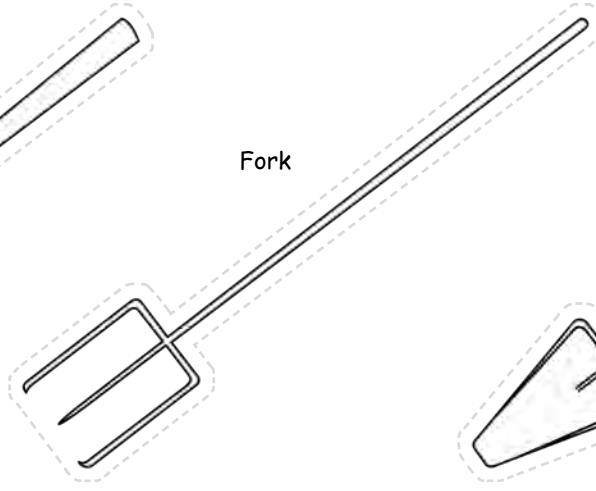
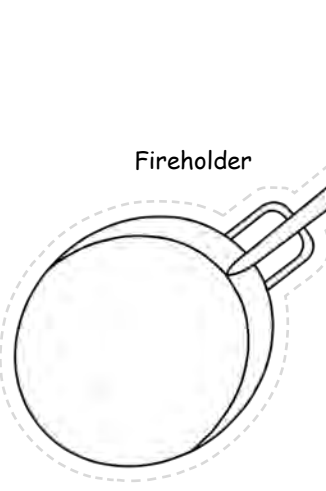

Pot

Bronze board

Acacia board

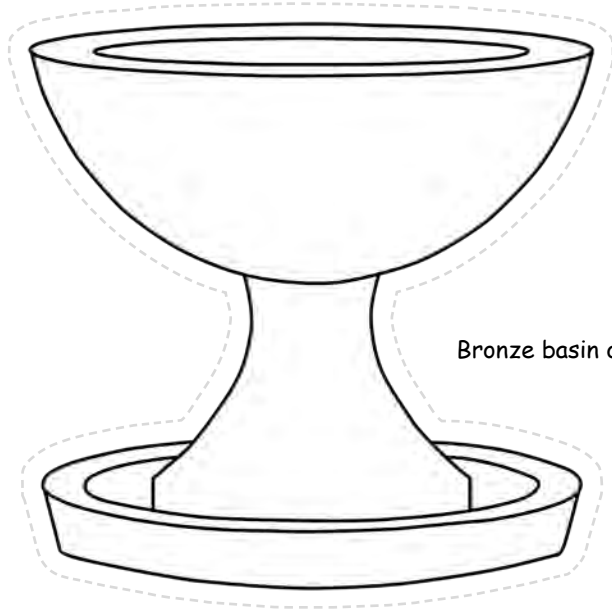
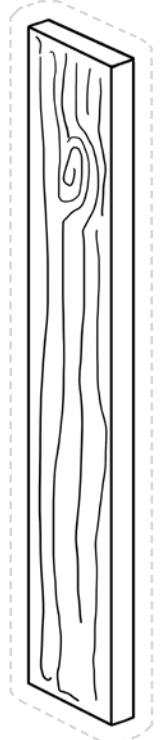
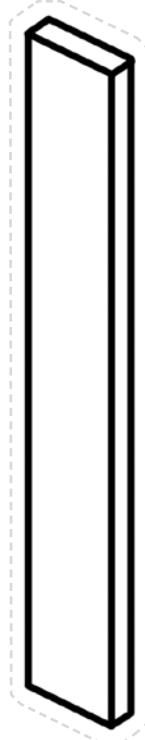
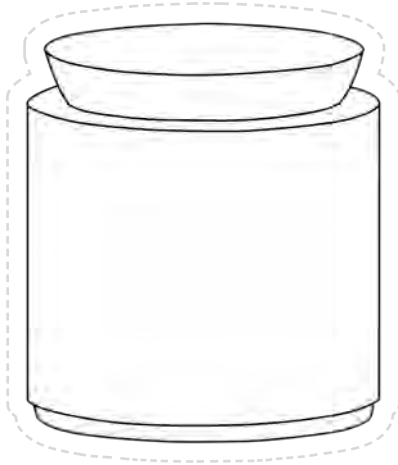

Bronze basin on stand

Bronze basin

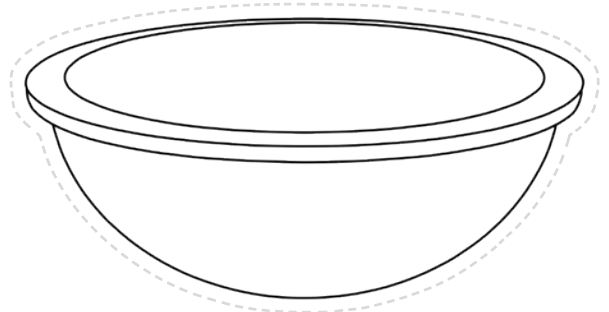

Counting What You Gained

This next section is intended to be reinforcement of the lessons learned during this parsha. Choose the activities that best fit your child.

STORING UP TREASURE IN MY HEART

The Katan Aleph memory verse for this Torah portion is Exodus 30:19. If they have not already done so, begin to help them to memorize the verse. Be creative and try acting it out, or putting it to music.

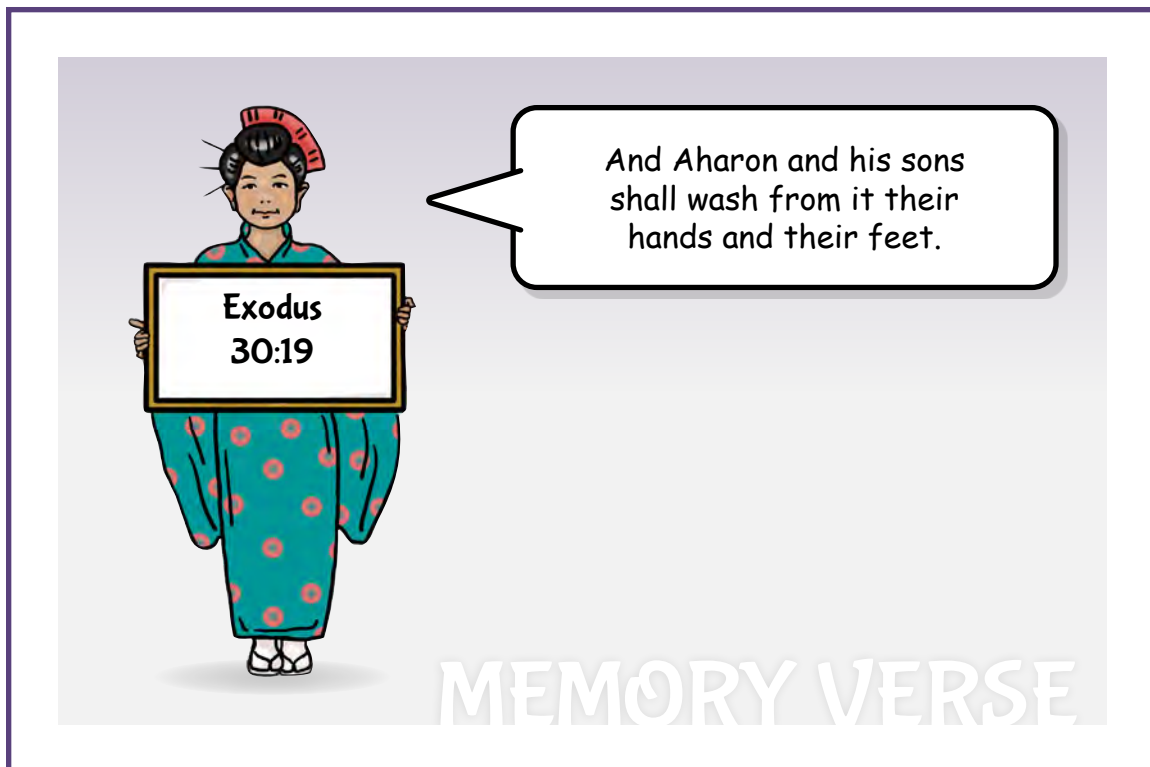

Exodus
30:19

And Aharon and his sons
shall wash from it their
hands and their feet.

MEMORY VERSE

SEEKING TREASURE

Circle the correct choices.

1. What metal were the altar, basin and stand made from? (27:2; 30:18)



2. How many horns did the altar have? (27:2)



3. How many columns were on the north and south side of the courtyard? (27:10-11)

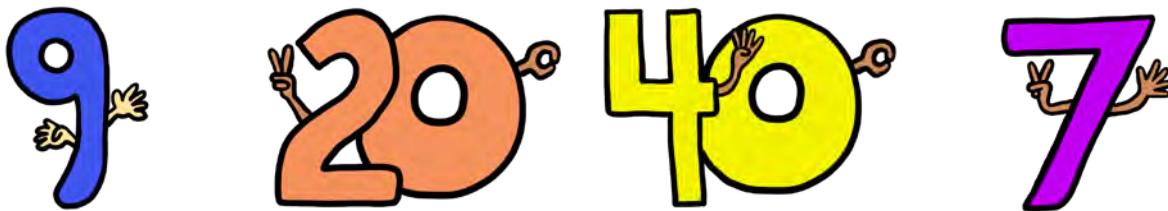

4. What colors were the coverings on the east gate made from? (27:16)

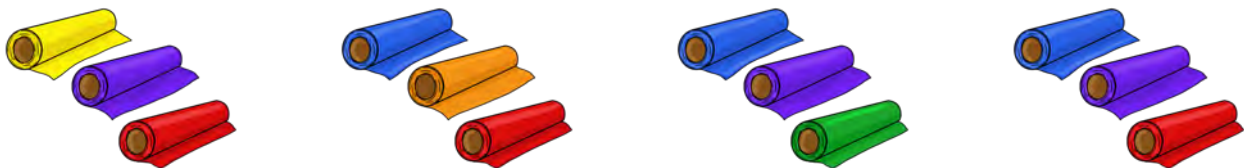

5. What did the bronze basin have in it? (30:18)



water

milk

blood

oil

WORD SEARCH

Search for the hidden words from this week's parsha.



ALTAR
COLUMNS
SCREENS
BASIN
BRONZE
GATE
COURTYARD



MAZE

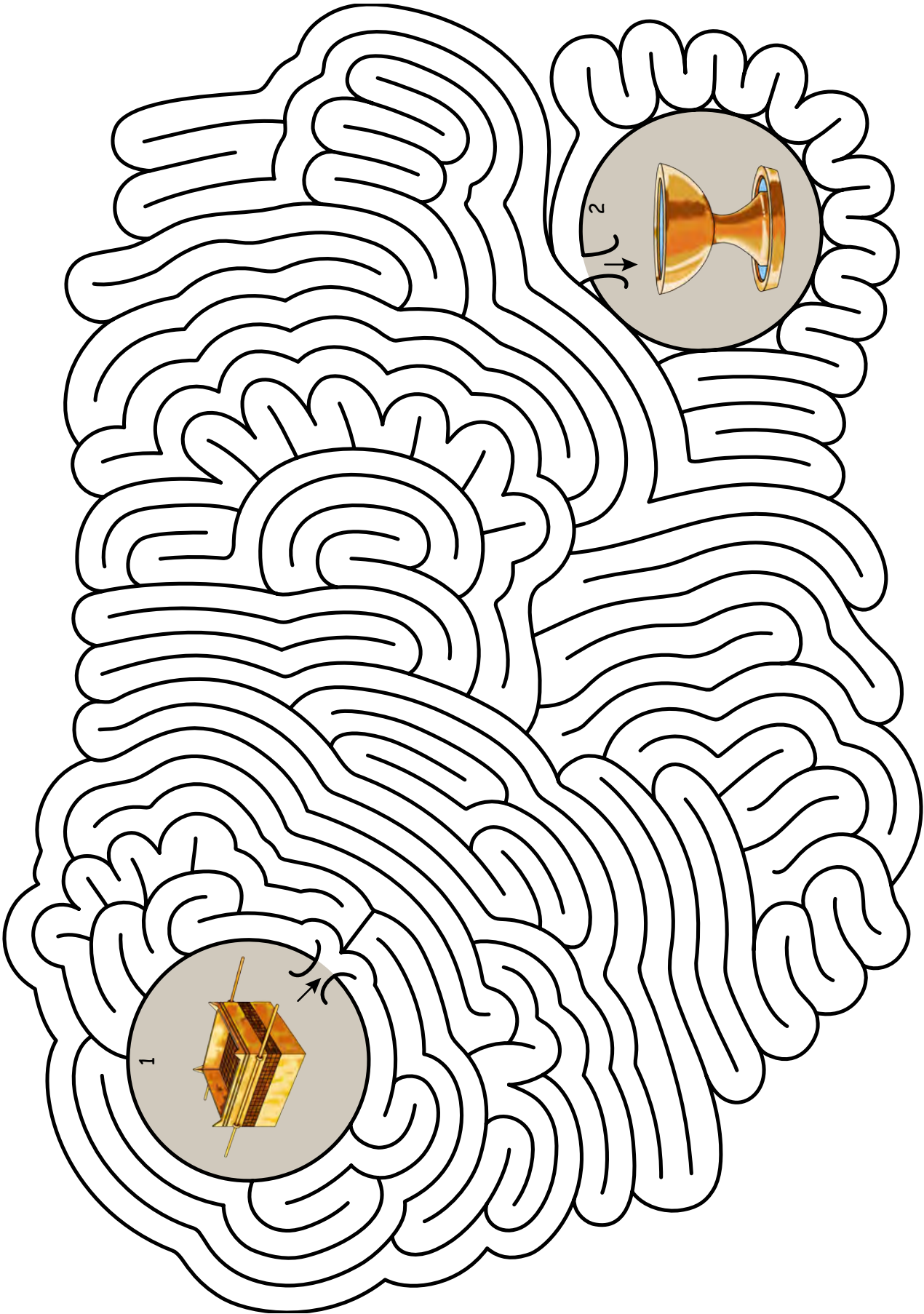

Precious Possessions

CRAFT

Materials:

- Plastic bowl
- Plastic shot glass
- Plastic lid (size of *Pringles* can lid)
- Hot glue gun
- Paint - bronze
- Paint brush
- Tissue paper - blue

Parent/Teacher Preparation:

- Review instructions to ensure how to execute the craft for your children.

Bronze Basin

Exodus 30:18



Instructions for the Craft:

- Using the hot glue gun, assemble the basin in the following order:
 - attach the plastic shot glass to the plastic lid. (P1a, P1b)
 - attach the plastic bowl to the top of the plastic shot glass. (P2a, P2b)
- Using the bronze colored paint, paint the entire basin. (P3)
- Place blue tissue paper in the upper and lower basin to represent water. (See Main Pic)

You now have a visual representation of the bronze wash basin that was in the courtyard used for washing the priest's hands and feet.



P1a



P1b



P2a



P2b



P3

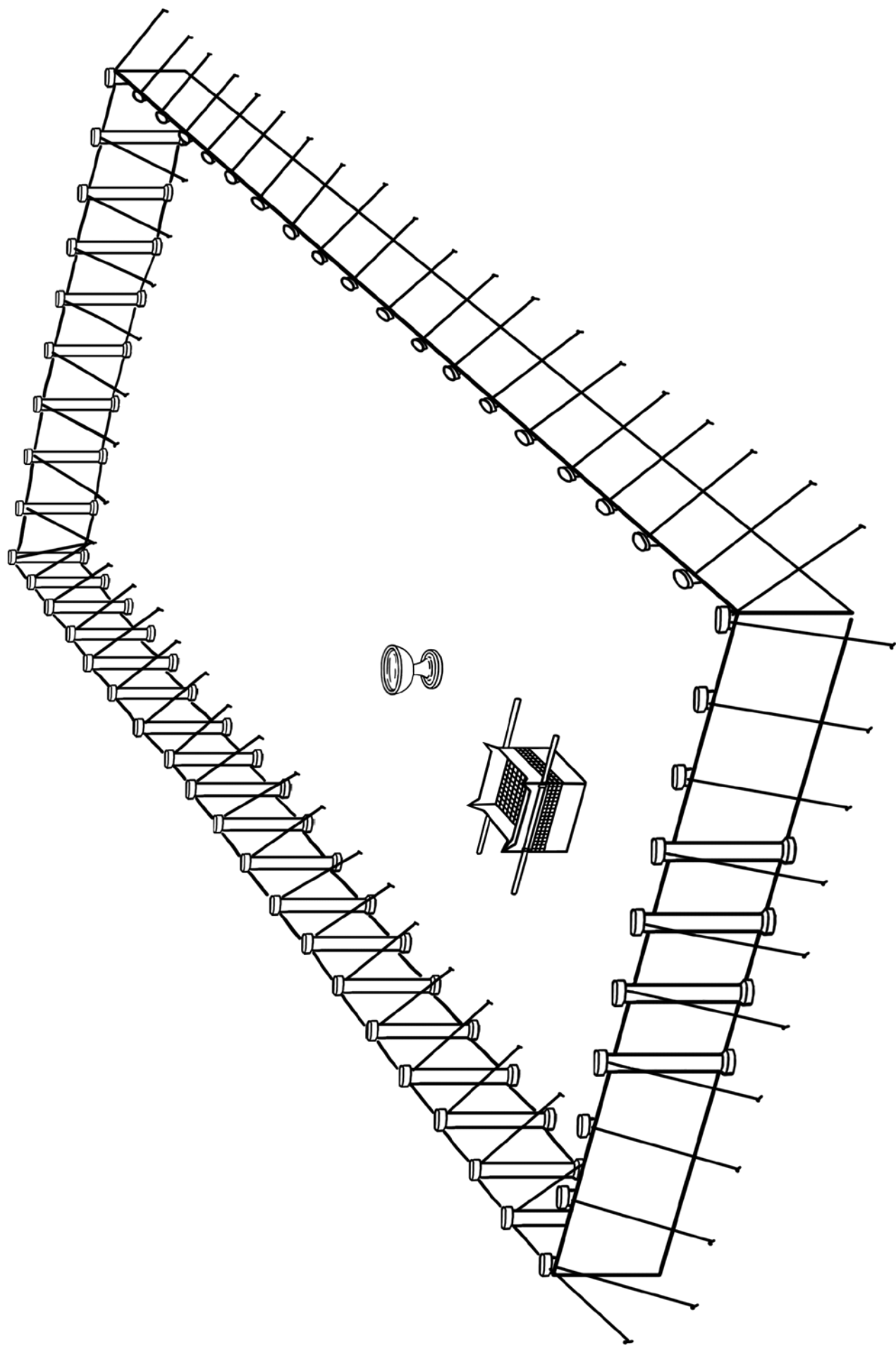

Sweetness of Torah

SWEET SOUNDS OF TORAH

(Sing Praises to His Name)

Here is the link for this song:

https://www.podomatic.com/podcasts/steveberkson/episodes/2023-03-03T13_00_00-08_00

The Bronze Basin

And you shall make a basin of bronze, of bronze
And put it between the Tent of Meeting and the altar
And Aharon and his sons shall wash from it their hands and feet
And it shall be a law forever to them and his seed

When they go into the Tent of Meeting and bring an offering
They'd wash their hands and their feet with water
And Aharon and his sons shall wash from it their hands and feet
And it shall be a law forever to them and his seed

And Aharon and his sons shall wash from it their hands and feet
And it shall be a law forever to them and his seed



SWEET TASTE OF TORAH

This snack relates to this week's parsha. Please take these as suggestions and make necessary changes based on your individual dietary needs.

Bronze Altar

Exodus 27:1-2 & 38:1-2



Ingredients:

- Square cookies - approx. 8-10 (represents the altar)
- Red frosting (represents the flames)
- 4 cashews (represents the horns)
- Animal cracker (represents the sacrificial animal)

Instructions:

Place the square cookies on top of each other to create the altar. Then pipe some red frosting in the center to create the fire flames. Place the cashews in the corners standing them upright and lay the animal cracker on the flames.

Next Week's Treasure Hunt

Next Week's Torah Portion

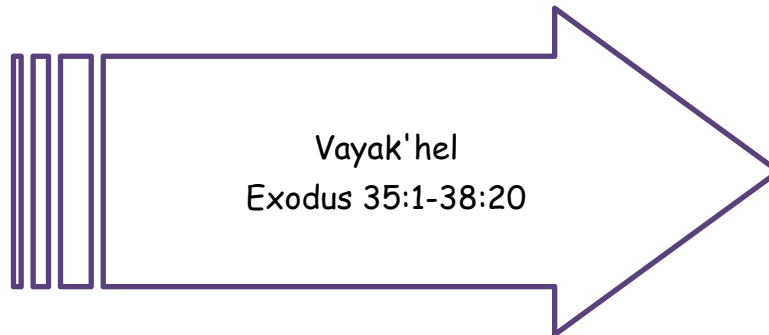

Suggested Reading Schedule

Monday:	Ex. 35:1-29	Sabbath instructions; Contributions for the tabernacle
Tuesday:	Ex. 35:30-36:7	Introducing Betsal'el and Oholiab
Wednesday:	Ex. 36:8-38	Curtains, coverings, boards, veil, columns for the Dwelling Place
Thursday:	Ex. 37:1-29	Making the ark, the table of showbread, lampstand, altar of incense, the anointing oil and incense
Friday:	Ex. 38:1-20	Making the bronze altar, the bronze basin and the courtyard