

Parsha Pearls

Ki Tisa

"When You Take Up"

Exodus 30:11 - 34:35

Katan Bet/Gadol



In This Edition:

21.2 - Blueprints for the Courtyard

Exodus 27:1-19; 30:17-21; 38:1-20; 40:6-7



Table of Contents

Parsha Pearls is a comprehensive resource that allows for complete customization by the parent. We understand that if you were to strive to accomplish all aspects of each lesson in one day it would be unrealistic and also overload for the child. It is our intention that this be used 'a la carte' so that it suits your specific needs. Our site caters to printing only the pieces you choose.

This page will provide quick links to get to the portion of the document for which you are looking. When you hover over the title a finger will appear. Click on it and you will be taken directly to that page.

If you are new to Parsha Pearls, we have created an [Introduction](#) document outlining how to use our lessons, as well as a [Scriptural Inspiration](#) document, which explains our titles and the Scriptural inspiration for them. We pray that Parsha Pearls blesses your home and that your children will grow to love the Word and to never depart from keeping Torah. As always, feel free to email us at parshapearls@mtoi.org if you have any questions.

Pearl Seeking (The Main Lesson)	3
➤ Treasuring His Word (Overview of the Parsha)	3
➤ Parsha Points (Main Lesson Content)	3
➤ Digging Deeper (Thought Provoking Questions)	9
Searching Out Hebrew (Reading & Writing)	10
➤ Words	10
➤ Numbers	10
➤ Word Match	11
➤ Flashcards	12
➤ Writing Hebrew	13
Counting What You Gained (Worksheets)	14
➤ Storing Up Treasure In My Heart (Memory Verse)	14
➤ Seeking Treasure (Questions from the Parsha)	16
➤ Word Search	18
➤ Crossword Puzzle	22
➤ Maze	24
➤ Worksheets	25
Precious Possessions (Arts & Crafts)	29
➤ Notebook Page	29
» Furniture Pieces for the Courtyard	29
➤ 3-D Craft	33
» Furniture Pieces for the Courtyard	33
➤ Coloring Page	41
Sweetness of Torah	42
➤ Sweet Sounds of Torah (Song Corresponding to the Parsha)	42
➤ Sweet Taste of Torah (Snack Corresponding to the Parsha)	43
Next Week's Treasure Hunt (Looking Ahead to Next Week's Parsha)	44



Pearl Seeking

TREASURING HIS WORD

Let's do a quick overview of the entire Torah portion:

Monday:	Ex. 30:11-31:18	The half-shekel contribution to Yahweh; The bronze basin, anointing oil and incense; Appointing Betsal'el and Oholiab, Sabbath instruction; The 2 tablets of the Witness
Tuesday:	Ex. 32	The golden calf incident
Wednesday:	Ex. 33:1-11	Seeking Yahweh after the golden calf incident; The Tent of Meeting outside the camp
Thursday:	Ex. 33:12-23	Mosheh asks to see Yahweh's esteem
Friday:	Ex. 34	Mosheh cuts the second tablet of stones and sees Yahweh's esteem; The 13 attributes of Yahweh; Instruction to the children of Yisra'el

Our journey through the last few parshas have taught us about the Dwelling Place that Yahweh wanted the children of Yisra'el to build for Him. In this week's Parsha Pearls lessons we will continue learning about the Dwelling Place, and will now cover the making of the courtyard and its furnishings - the bronze altar, its utensils and the bronze wash basin. In order to get the most complete picture of the courtyard, this lesson will include verses from other parshas as well. Now, let's read Ex. 27:1-19; 30:17-21; 38:1-20 & 40:6-7.

Terms to know: For the following 3 terms, we at MTOI have chosen to use the wording in the earlier edition (98" version) of the ISR Scriptures. Please use this as a resource for your study.

Tent of Meeting = Tent of Appointment
altar = slaughter-place
burnt offering = ascending offering

PARSHA POINTS

Altar (27:1-8; 38:1-7; 40:6)

- Yahweh's specifications for the altar (**mizbeach**)
 - made of acacia wood
 - hollow with boards, as shown on the mountain
 - overlaid with bronze (**nechoshet**)
 - its shape was to be a square
 - to be placed before the door of the Dwelling Place of the Tent of Meeting

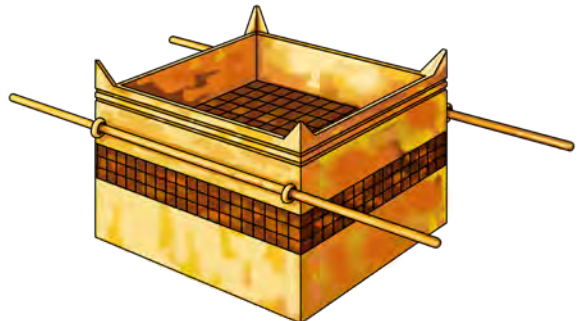

- The altar's measurements
 - 5 (**chamesh**) cubits long ($7\frac{1}{2}$ ft.)
 - 5 cubits wide ($7\frac{1}{2}$ ft.)
 - 3 (**shalosh**) cubits high ($4\frac{1}{2}$ ft.)
- The altar's parts
 - 4 (**arba**) horns on its 4 corners - all the same size
 - 1 (**achat**) removable bronze grating network under the rim, placed halfway up the altar
 - 4 bronze rings at its 4 corners, as holders for the 2 (**shtayim**) poles

Poles for Altar (27:6-7; 38:6-7)

- Yahweh's specifications for the poles
 - 2 poles
 - made of acacia wood
 - overlaid with bronze
 - each pole was to be inserted into 2 rings on each side of the altar
 - their purpose was to help lift the altar



Bronze Utensils for Altar (27:3, 19; 38:3)

- pots and pans - to hold the ashes that were taken outside the camp
- shovels - used to clear away the ashes from the altar and place them into the pots/pans
- basins - the priests would catch the blood in the basin and use it to sprinkle blood on the altar and pour blood at the base of the altar
- forks - an instrument with 3 prongs used for placing the pieces of the offering upon the altar
- fire holders and fire pans - for moving coals from the bronze altar to the altar of incense

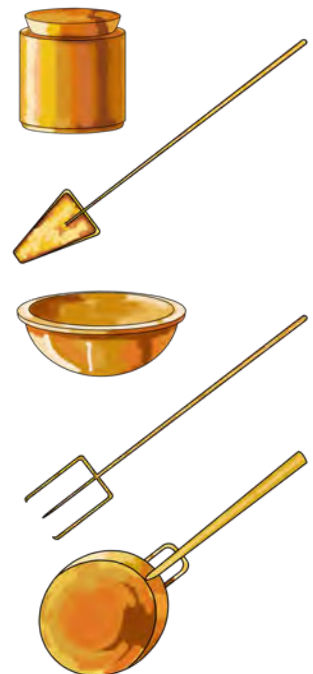

Wash Basin and Stand (30:17-21; 40:7)

- Yahweh's specifications for the wash basin (**kiyor**) and stand
 - made completely of bronze
 - to be placed between the Tent of Meeting and the altar
 - to have water in it
- The basin and stand were made from the bronze mirrors of the serving women who did service at the door of the Tent of Meeting - 38:8
- Aharon and his sons were to wash their hands and feet in the basin when they:
 - went into the Tent of Meeting
 - came near the altar to attend it
 - offered an offering made by fire to Yahweh
- The priests were to wash their hands and feet with water from the basin before performing their service - a law forever to them and their seed, lest they die - 30:20-21



Courtyard (**Khatzer**) of the Dwelling Place (27:9-19; 38:9-20)

- Measurements of the courtyard
 - 100 (**me'ah**) cubits long (150 ft.)
 - 50 (**chamishim**) cubits wide (75 ft.)
 - 5 cubits high (7½ ft.)
- Screens
 - made of fine woven linen
 - 5 screens (1 on the south, 1 on the north, 1 on the west, 2 on the east) - on each side of the gate
 - suspended from columns/pillars which were 5 cubits apart (7½ ft.)

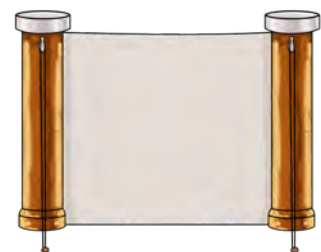
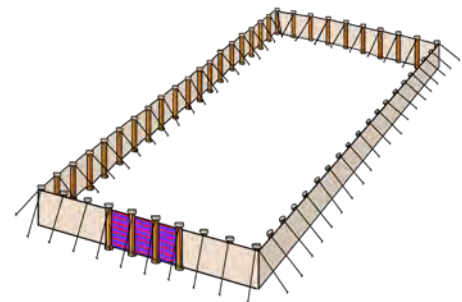

- Measurements of the screens
 - 100 cubits long (150 ft.) on south
 - 100 cubits long (150 ft.) on north side
 - 50 cubits wide (75 ft.) on west side
 - 30 (**shloshim**) cubits wide (45 ft.) on east side (to allow for the 20-cubit (**esrim**) gate)
 - 5 cubits high (7½ ft.) on all sides

- Columns, Sockets, Pegs

- made of bronze
- 60 (**shishim**) bronze columns
- 60 bronze sockets
- 60 pegs

- Bands and Hooks

- made of silver
- 60 bands
- 60 hooks

South and North side

- Screens

- made of fine woven linen
- 1 screen on each side

- Measurements of the screens

- 100 cubits long (150 ft.) on each side
- 5 cubits high (7½ ft.) on each side

- 40 (**arba'im**) bronze columns (20 on each side)
- 40 bronze sockets and pegs (20 on each side)
- 40 silver bands (20 on each side)
- 40 silver hooks (20 on each side)

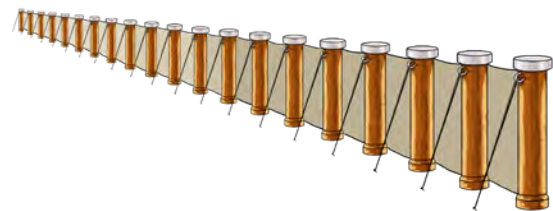
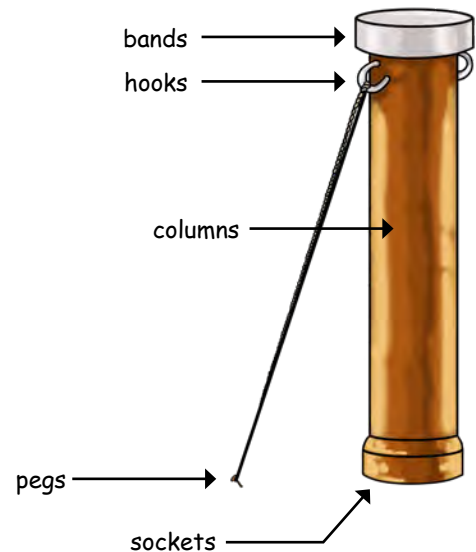

West side

- Screen
 - made of fine woven linen
 - 1 screen
- Measurements of the screen
 - 50 cubits wide (75 ft.)
 - 5 cubits high (7½ ft.)
- 10 (**eser**) bronze columns
- 10 bronze sockets and pegs
- 10 silver bands
- 10 silver hooks



East side

- Screens
 - made of fine woven linen
 - 2 screens
 - 6 (**shesh**) bronze columns
 - 6 bronze sockets and pegs - (3 on each side of the gate)
 - 6 silver bands
 - 6 silver hooks
- Measurements of the screens
 - 30 cubits wide (45 ft.)
 - screens on either side of the gate were each 15 (**chamesh esre**) cubits (22½ ft.)

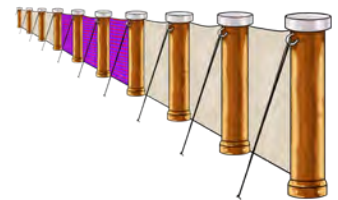

Gate

- made of fine woven linen, using 3 colors
 - blue
 - purple
 - scarlet
- had 4 bronze columns
- had 4 bronze sockets and pegs
- had 4 silver bands
- had 4 silver hooks
- Measurements of the gate
 - 20 cubits wide (30 ft.)
 - 5 cubits high (7½ ft.)

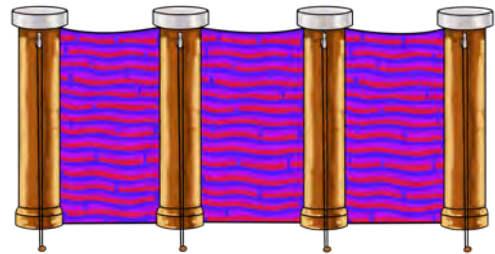

Fun Facts

- The length and width of the courtyard created 2 perfect squares. (75 ft. x 75 ft.)
- The pegs of bronze were like nails that were driven into the ground, to which the ropes/cords were attached. The pegged cords added strength and protection from wind, etc.
- We are told how they were to carry the altar - on its poles, but we are not told how they were to carry the wash basin.
- The priest would change out of his priestly garments and take the ashes from the bronze altar to a designated place outside the camp.
- The bronze grating allowed the fat to drip down and the ashes to fall below.
- The bronze grating was the same distance from the ground as the lid of atonement on the ark.

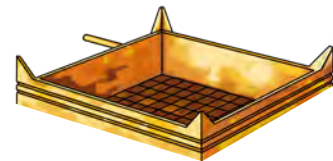
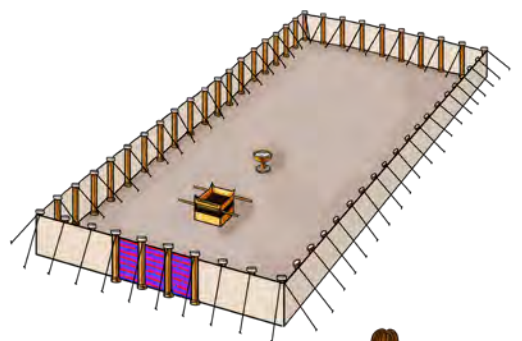

DIGGING DEEPER

Parents/Teachers may choose to use these prompts for further discussion of the Torah portion.

- What was the purpose of the horns on the bronze altar?
- Why do you think Yahweh had rings placed on the altar in order to hand carry it, instead of allowing it to be placed onto a wagon?
- Research the 5 types of offerings made on the bronze altar (found in Leviticus 1-6).
- Talk about the importance of following the pattern exactly so. What would happen if they created the tabernacle the way they wanted to, or used inferior materials?
- Why do you think Yahweh gave details about what to do with the ashes? Why were they taken to a clean place outside the camp, and why did the priest have to put on special clothing to do this?



Searching Out Hebrew

Parents/Teachers can print out the '[Hebrew Pronunciation Guide](#)' to help with the pronunciation of Hebrew names and words. They can be cut out and used in conjunction with the Flashcards.

WORDS

Parents/Teachers see the following page for 3 x 5 card cut outs of the words from this week's parsha. If printed on cardstock, they can be kept in a box to reinforce learning.

Mizbeach (**מִזְבֵּחַ**) - altar

Nechoshet (**נְחֹשֶׁת**) - bronze

Khatzer (**חֲצֵר**) - courtyard

Kiyor (**כִּיּוֹר**) - basin

NUMBERS

Parents/Teachers can print out these numbers to have as additional resources. These can be found under the 'Resources' tab on the YMTOI website.

1 - achat

2 - shtayim

3 - shalosh

4 - arba

5 - chamesh

6 - shesh

10 - eser

15 - chamesh esre

20 - esrim

30 - shloshim

40 - arba'im

50 - chamishim

60 - shishim

100 - me'ah

WORD MATCH

Match this week's Hebrew words to their correct definition.

Khatzer

Altar

Kivor

Basin

Mizbeach

Bronze

Nechoshet

Courtyard



FLASHCARDS

נחשת

Nechoshet

Ne-cho-shet

bronze

כִּיּוֹר

Kiyor

Ki-yor

basin

מִזְבֵּחַ

Mizbeach

Miz-be-ach

altar

חַצְרָה

Khatzer

Kha-tzer

courtyard



WRITING HEBREW

Nechoshet (bronze)

נחשת

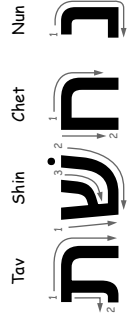

Mizbeach (altar)

מזבח

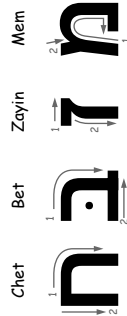

Kiyor (basin)

כּיּוּר

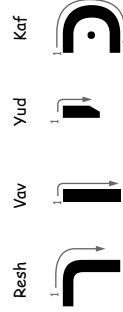

Khatzer (courtyard)

חצר

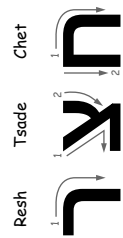

Counting What You Gained

This next section is intended to be reinforcement of the lessons learned during this parsha. Choose the activities that best fit your child.

STORING UP TREASURE IN MY HEART

The Katan Bet and Gadol memory verse is Exodus 30:18. You can review the verse with them by reciting it out loud, acting it out, putting it to music... whatever works for you.

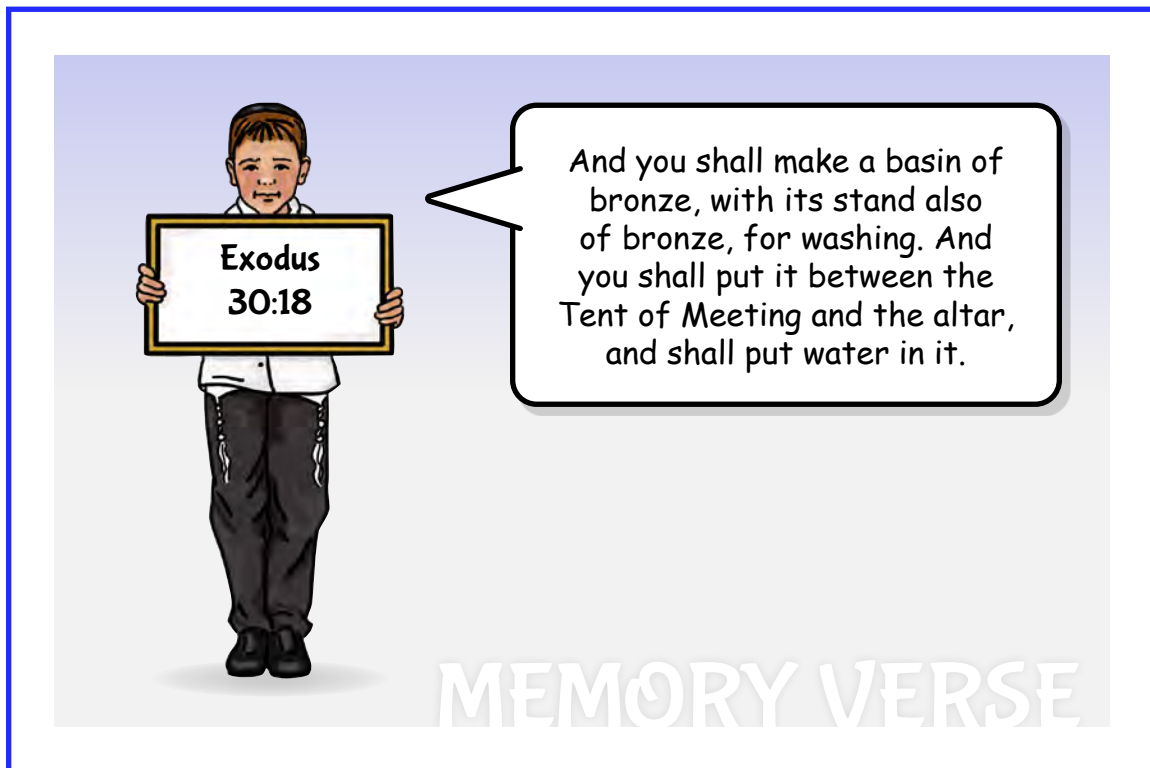

SEEKING TREASURE

1.



The altar was a perfect rectangle.

T / F

(27:1)

2.



The altar had 4 horns.

T / F

(27:2; 38:2)

3.



Which utensils were used for the altar?

Circle the correct choices.

pots spoons shovels basins

forks fire holders ladles

graters carving knives

(27:3; 38:3)

4.

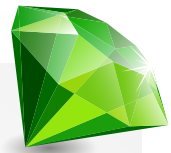

The screens for the courtyard were made of this material.

Circle the correct choice.

linen wool rams' skins dyed red

polyester rayon burlap

cotton leather goat's hair

(27:9; 38:9, 16)

5.

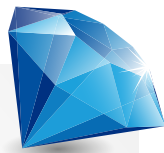

As it was _____ to you on the _____, so they are to _____ it.

(27:8b)

6.



The west side of the courtyard had a gate.

T / F

(27:13-16; 38:13-15)

7.

Which tabernacle furnishings were made completely out of bronze?

Circle the correct choices.

wash basin altar ark of the covenant
pots/pans lampstand table of showbread shovels
basins forks fire holder/fire pans

(27:3, 29; 30:18; 38:3, 8)



8.

And you shall make a _____ of bronze, with its _____ also of bronze,
for _____. And you shall put it between the _____
and the _____, and shall put _____ in it.

(30:18)



9.

Aharon and his sons were to wash
their face, hands and feet in the
bronze wash basin—a law forever.

T / F

(30:19)



WORD SEARCH

Search for the hidden words from this week's parsha.

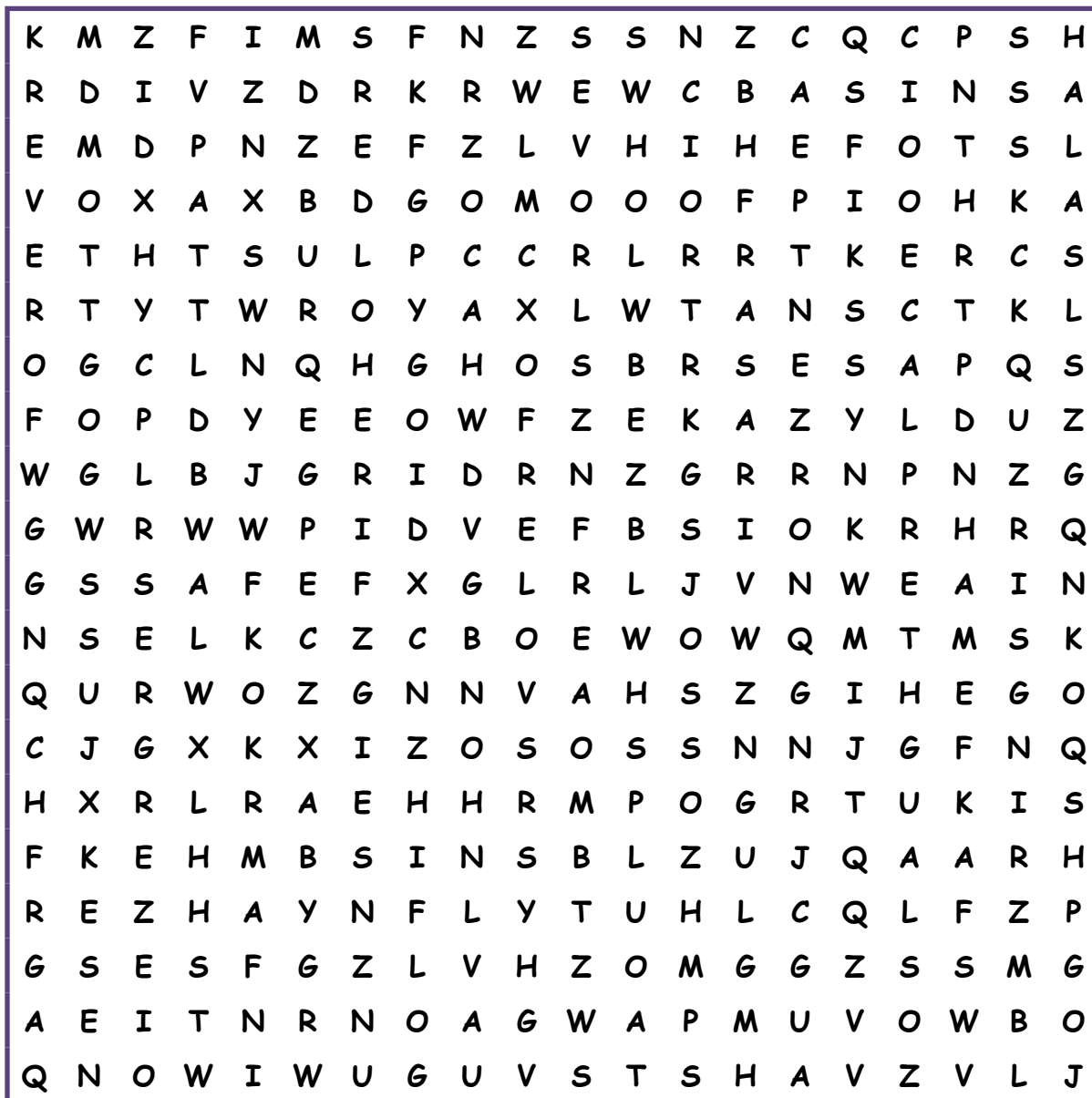

SLAUGHTER-PLACE

ASHES

FORKS

GRATING

POLES

WASHING

LAW

HORNS

SHOVELS

FIRE HOLDERS

NETWORK

HOLLOW

HANDS

FOREVER

POTS

BASINS

BRONZE

RINGS

BRONZE BASIN

FEET

GENERATIONS



Answer Key

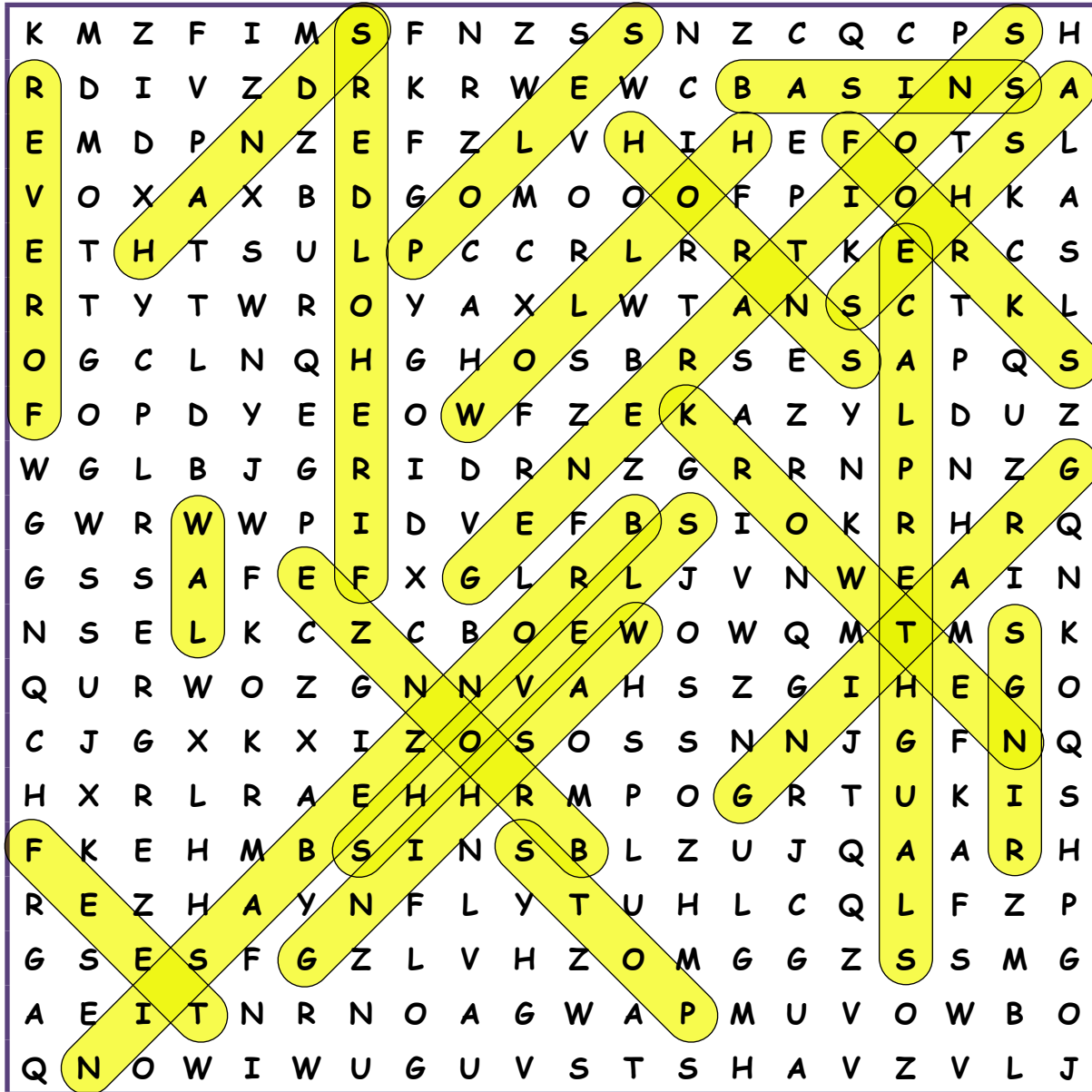

SLAUGHTER-PLACE

ASHES

FORKS

GRATING

POLES

WASHING

LAW

HORNS

SHOVELS

FIRE HOLDERS

NETWORK

HOLLOW

HANDS

FOREVER

POTS

BASINS

BRONZE

RINGS

BRONZE BASIN

FEET

GENERATIONS



WORD SEARCH

Search for the hidden words from this week's parsha.

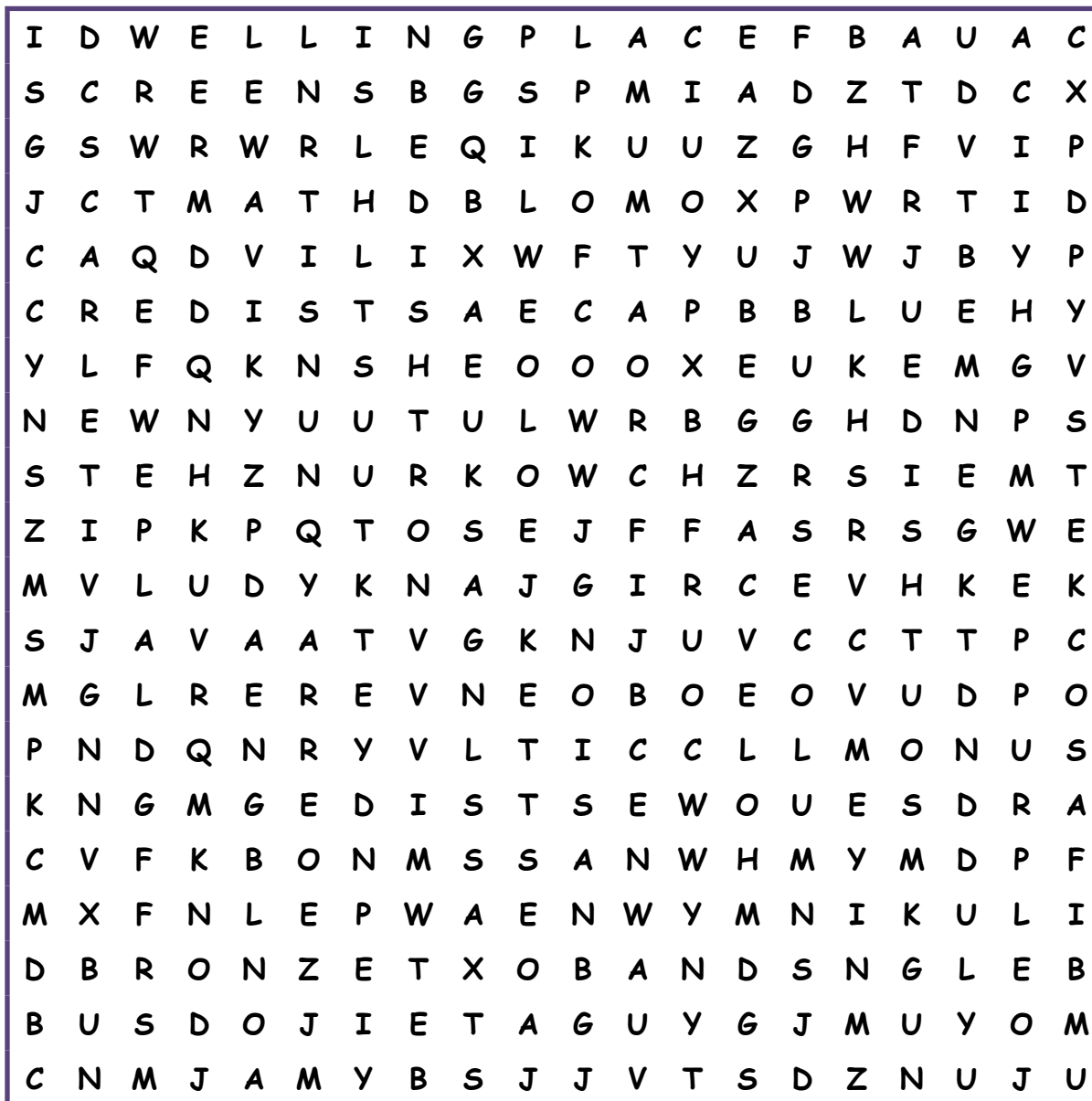

DWELLING PLACE

COURTYARD

NORTH SIDE

SOUTH SIDE

EAST SIDE

WEST SIDE

SCREENS

GATE

BLUE

PURPLE

SCARLET

WEAVER

FINE LINEN

COVERING

COLUMNS

CUBITS

SOCKETS

SILVER

BANDS

BRONZE

PEGS



Answer Key

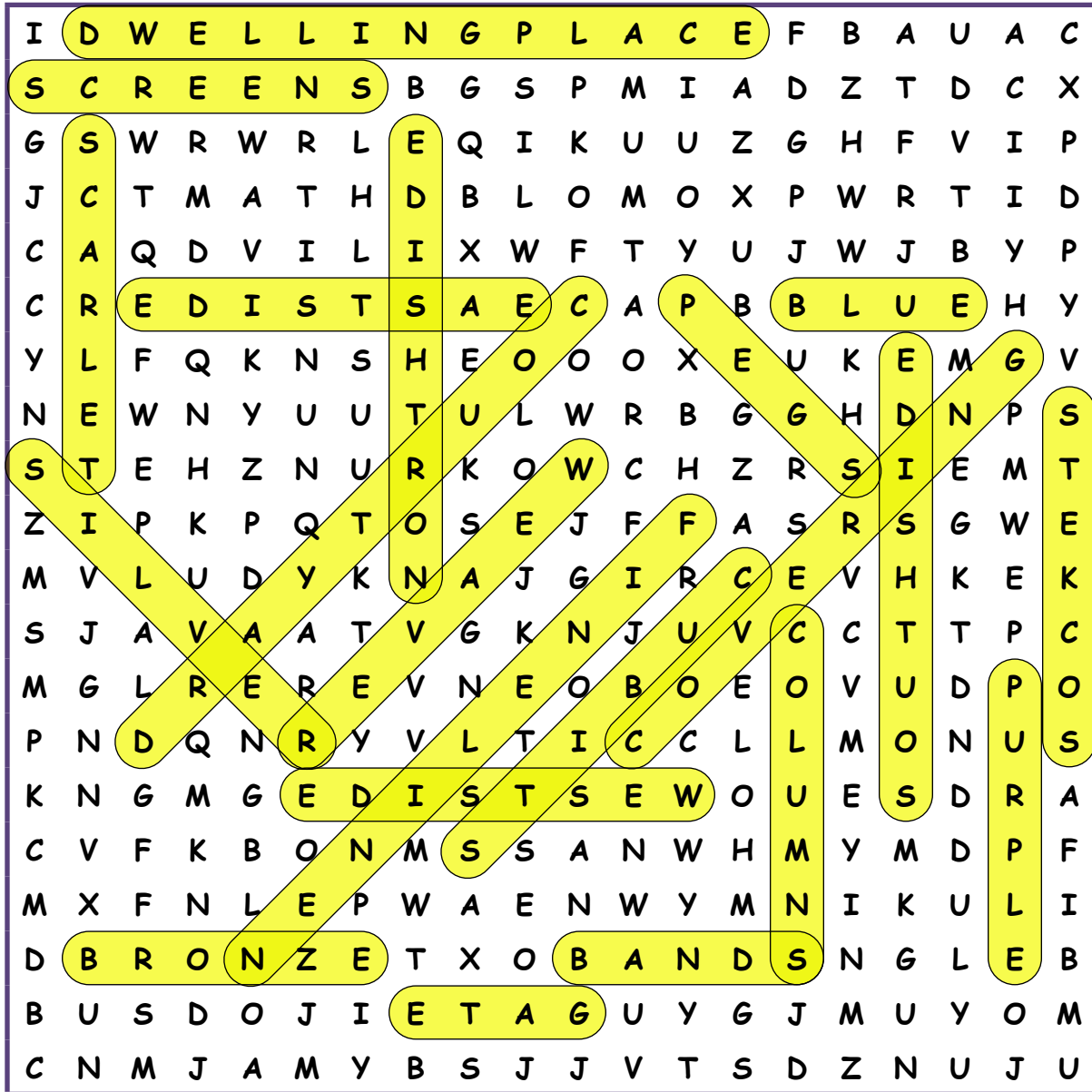

DWELLING PLACE

COURTYARD

NORTH SIDE

SOUTH SIDE

EAST SIDE

WEST SIDE

SCREENS

GATE

BLUE

PURPLE

SCARLET

WEAVER

FINE LINEN

COVERING

COLUMNS

CUBITS

SOCKETS

SILVER

BANDS

BRONZE

PEGS



CROSSWORD PUZZLE

Complete the crossword using words from this week's parsha.

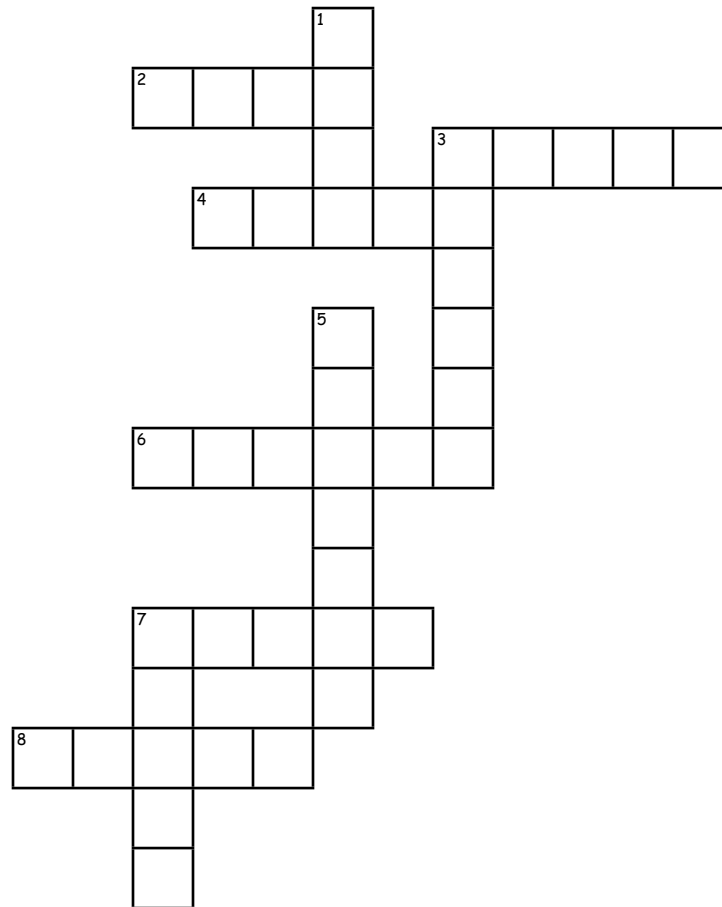

Across

2. What part of the courtyard had blue, purple and scarlet material?
3. The bronze _____ was placed between the Tent of Meeting and the altar.
4. What was placed in the bronze basin?
6. What shape was the altar?
7. What was on the 4 corners of the altar?
8. What material were the screens made of?

Down

1. Aharon and his sons were commanded to wash their hands and _____ in the bronze basin.
3. What type of metal were the pegs and utensils made from?
5. What was half-way up the altar?
7. Aharon and his sons were commanded to wash their _____ and feet in the bronze basin.



Answer Key

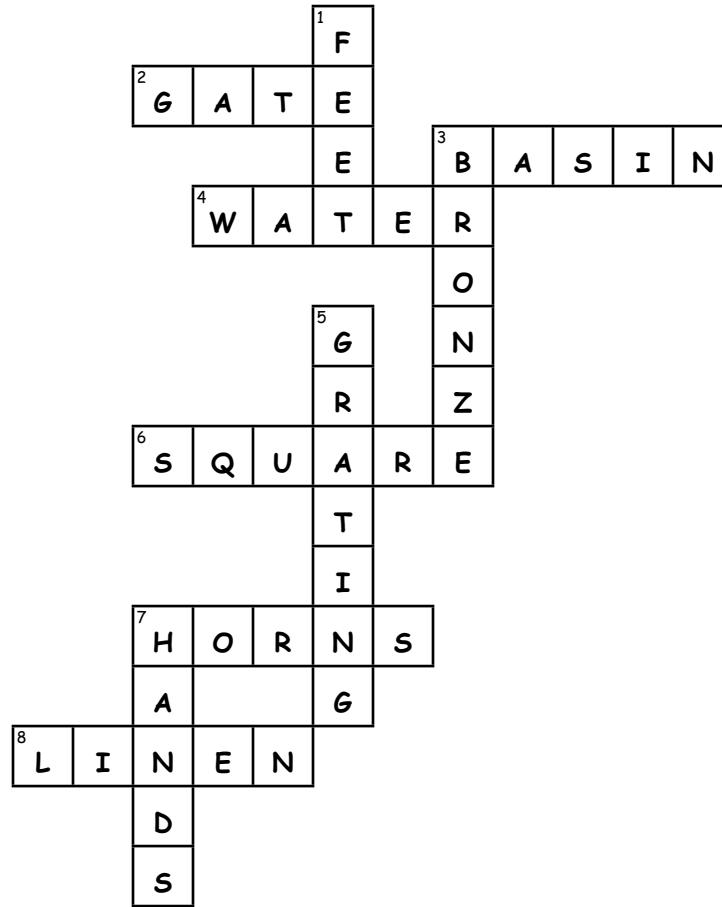

Across

2. What part of the courtyard had blue, purple and scarlet material? **gate**
3. The bronze **basin** was placed between the Tent of Meeting and the altar.
4. What was placed in the bronze basin? **water**
6. What shape was the altar? **square**
7. What was on the 4 corners of the altar? **horns**
8. What material were the screens made of? **linen**

Down

1. Aharon and his sons were commanded to wash their hands and **feet** in the bronze basin.
3. What type of metal were the pegs and utensils made from? **bronze**
5. What was half-way up the altar? **grating**
7. Aharon and his sons were commanded to wash their **hands** and feet in the bronze basin.

MAZE

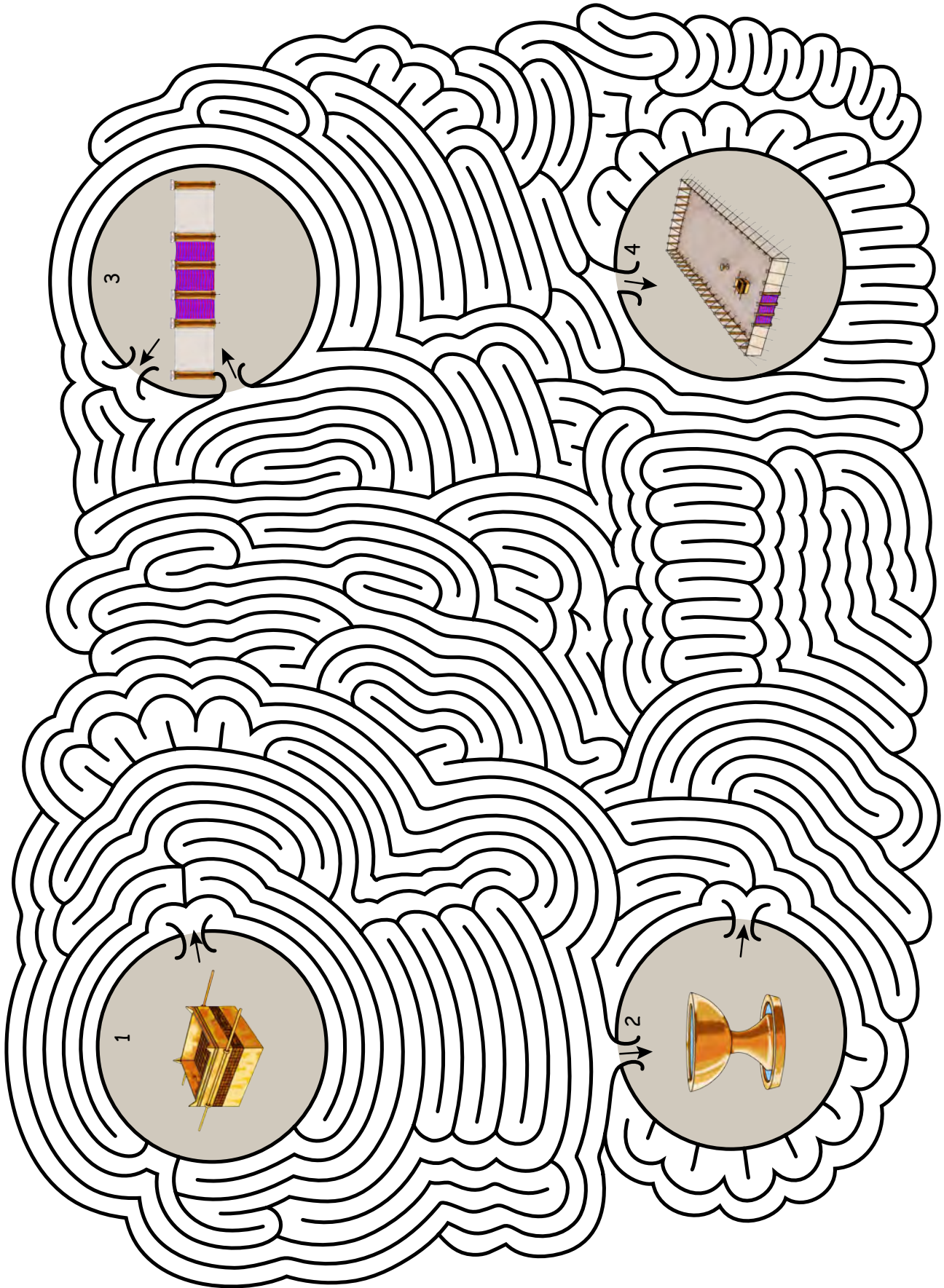

WORKSHEETS

Exodus 27:1-8; 38:1-7 describes the altar

Measurements for the altar
(27:1, 38:1):

_____ cubits long

_____ cubits wide

_____ cubits high

Label the following:

- (a) horns
- (b) bronze grating
- (c) poles
- (d) rings

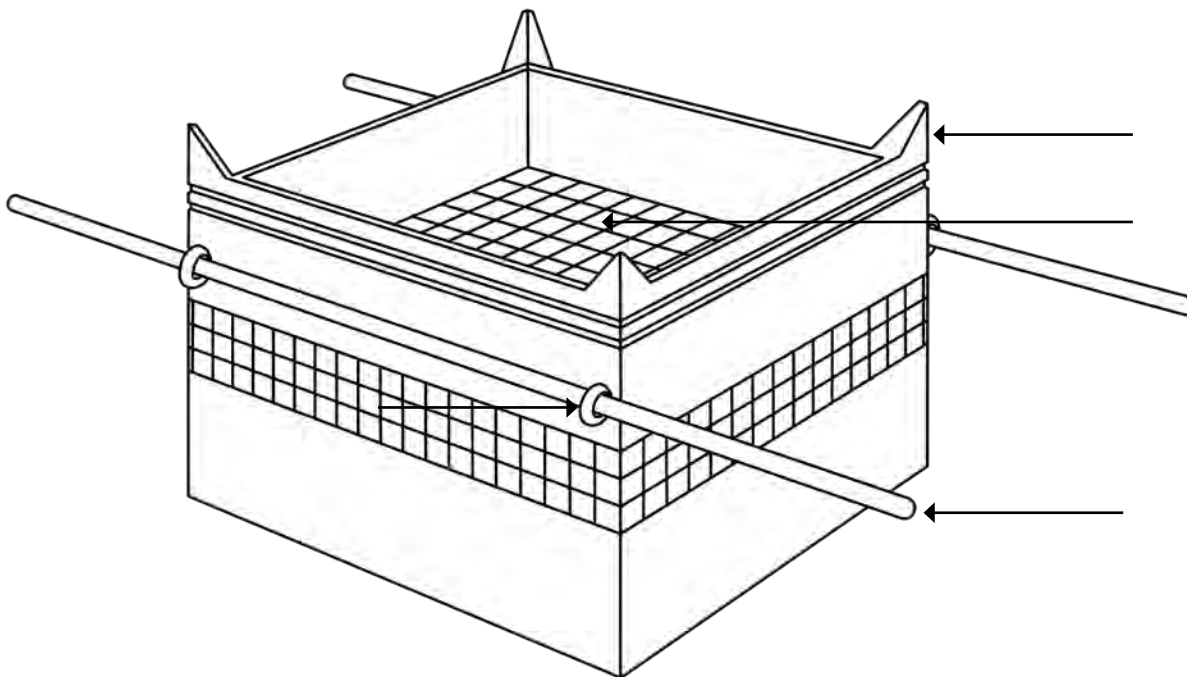

The altar and the poles are made of _____. (27:1, 6; 38:1, 6)

The altar and the poles overlaid with _____. (27:2, 6; 38:2, 6)

The rings are made of _____. (27:4)

Indicate how many of each:

rings (27:4; 38:5) _____

poles (27:7) _____

horns (27:2; 38:2) _____

Exodus 30:18-21; 38:8 describes the wash basin and stand

Use a blue crayon or pencil to color the areas of the basin where there would be water.

Label the following:

- (a) basin
- (b) stand

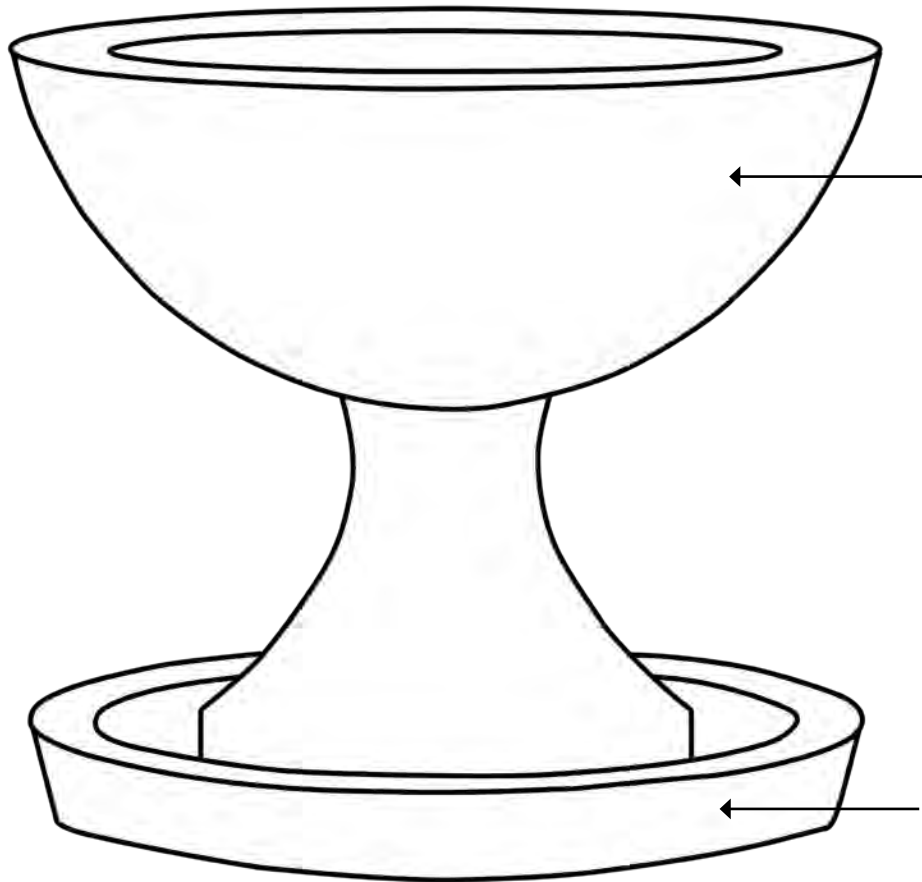

The basin and the stand are made of _____ (30:18; 38:8)
What was the basin and stand made from? bronze _____ (38:8)
What parts of the body were to be washed in the basin?
_____ and _____ (30:19, 21)



Exodus 27:9-18; 38:9-20 describes the courtyard

Measurements for the courtyard
(27:18):

_____ cubits long

_____ cubits wide

_____ cubits high

Label the following:

- (a) screen
- (b) column
- (c) rope
- (d) peg
- (e) east gate
- (f) band
- (g) hook
- (h) socket
- (i) north side
- (j) south side
- (k) east side
- (l) west side

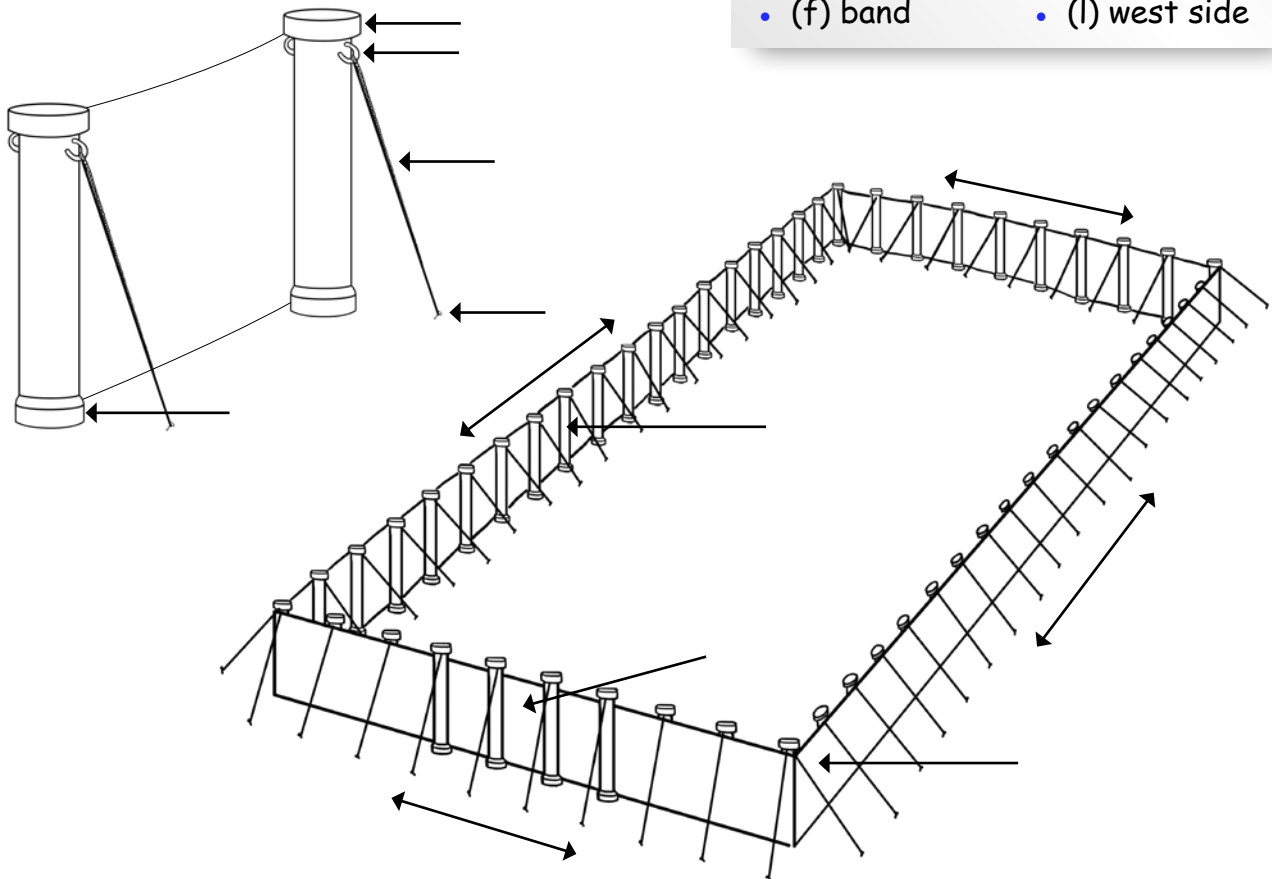

How many of the following are there on the courtyard?

- columns on the north and south side _____ (27:10-11)
- columns on the east and west side _____ (27:12-15)
- total columns _____
- screens on the north and south side _____ (27:9-11)
- screens on the east side _____ (27:14-15)
- screens on the west side _____ (27:12)

Exodus 27:13-16 describes the east gate

Measurements for the east gate
(v 16):

_____ cubits wide

_____ cubits high

Label the following:

- (a) screen
- (b) column
- (c) rope
- (d) peg
- (e) band
- (f) covering
- (g) socket

Inside view

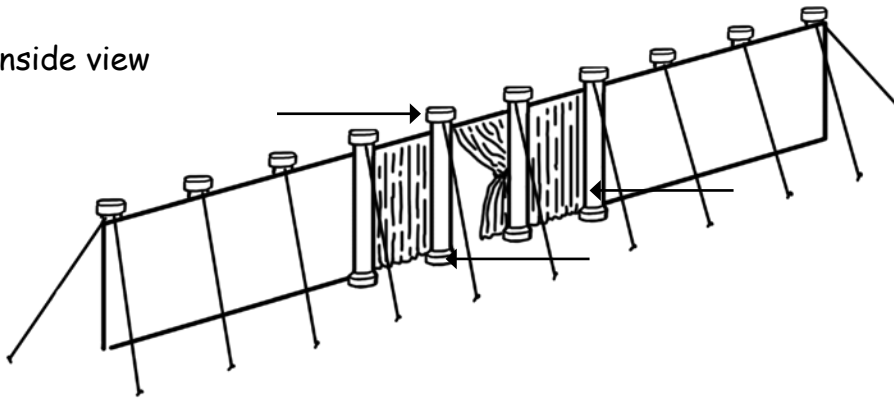

Outside view

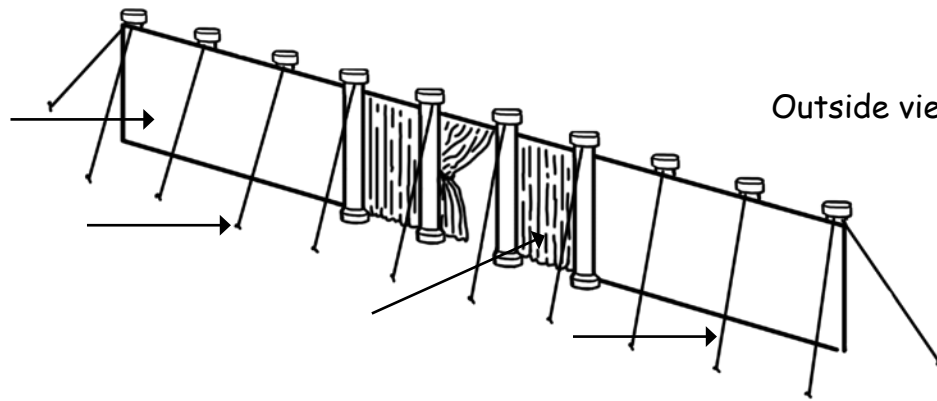

How many columns and sockets did the gate have? (v 16) _____

What colors were the coverings ? (v 16)

Color the coverings with the appropriate colors.

Precious Possessions

NOTEBOOK PAGE

Special Instructions:

We have created two different options for this craft. The first is for a standard Notebook Page. The second is a 3-D version of the two Furniture Pieces for the Courtyard. Parsha Terumah 19.1 KB lesson also had a craft option for the four 3-D Furniture Pieces for the Mishkan. We recommend that you store all the 3-D furnishings in a shoebox or plastic bin.

Materials:

- Cardstock - white
- Foam dimensional
- Puffy paint - copper shades (for furnishings) & blue (for water)
- Scissors
- Glue
- Coloring pencils, crayons or markers
- Optional: toothpick (to assist in placing puffy paint)
- Notebook Templates: A (BW) or B (color)

Parent/Teacher Preparation:

- Print Notebook Template of choice on white cardstock.

Furniture Pieces for the Courtyard

Exodus 27:1-8; 30:18



Instructions for the Standard Notebook Page:

- If using BW Template, color using medium of choice.
- Cut out all Template pieces. (P1)



P1

Instructions for the Standard Notebook Page Cont'd:

- Embellish the bronze basin and altar with copper and bronze puffy paint. You can add some to the grating and the poles on the altar as well. (P2a, P2b)
- Set pieces aside to dry.
- Once pieces are dry, add foam dimensionals to the back of each piece. (P3)
- Glue each furniture piece to a sheet of cardstock. (P4)



P2a



P2b



P3

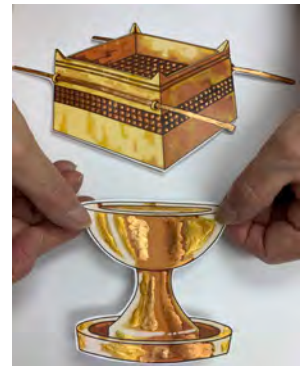

P4

Hebrew Words

- Write the following directly on the Main Page or on a piece of colored cardstock and glue to the page:

- | | | |
|----------------|-------------|----------------|
| ➤ 1) Mizbeach | 2) מזבח | 3) Altar (P5) |
| ➤ 1) Nechoshet | 2) נחשת | 3) Bronze (P6) |
| ➤ 1) Kiyor | 2) כִּיּוֹר | 3) Basin (P7) |



P5



P6

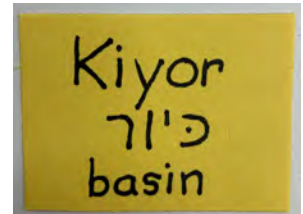

P7

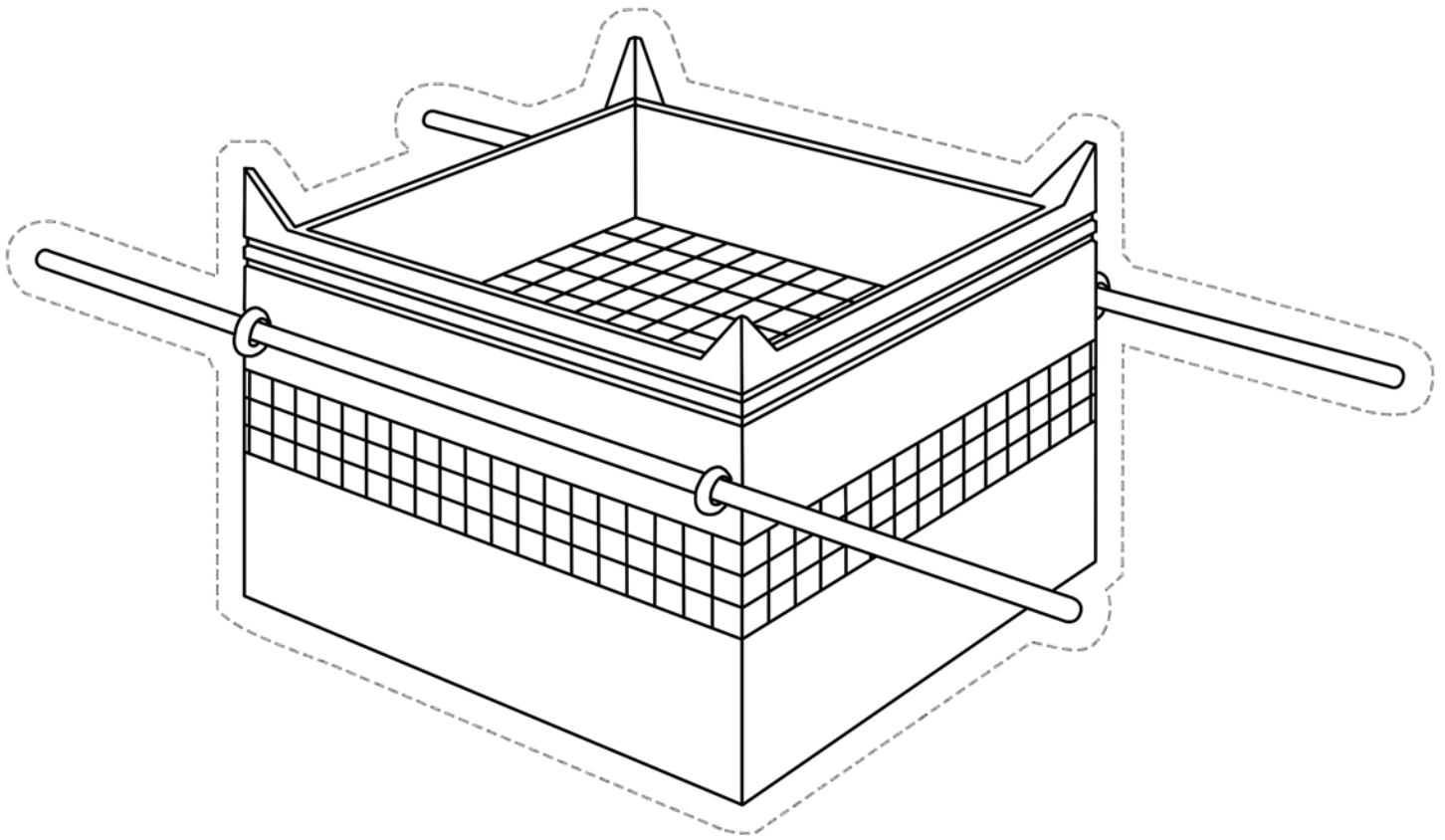

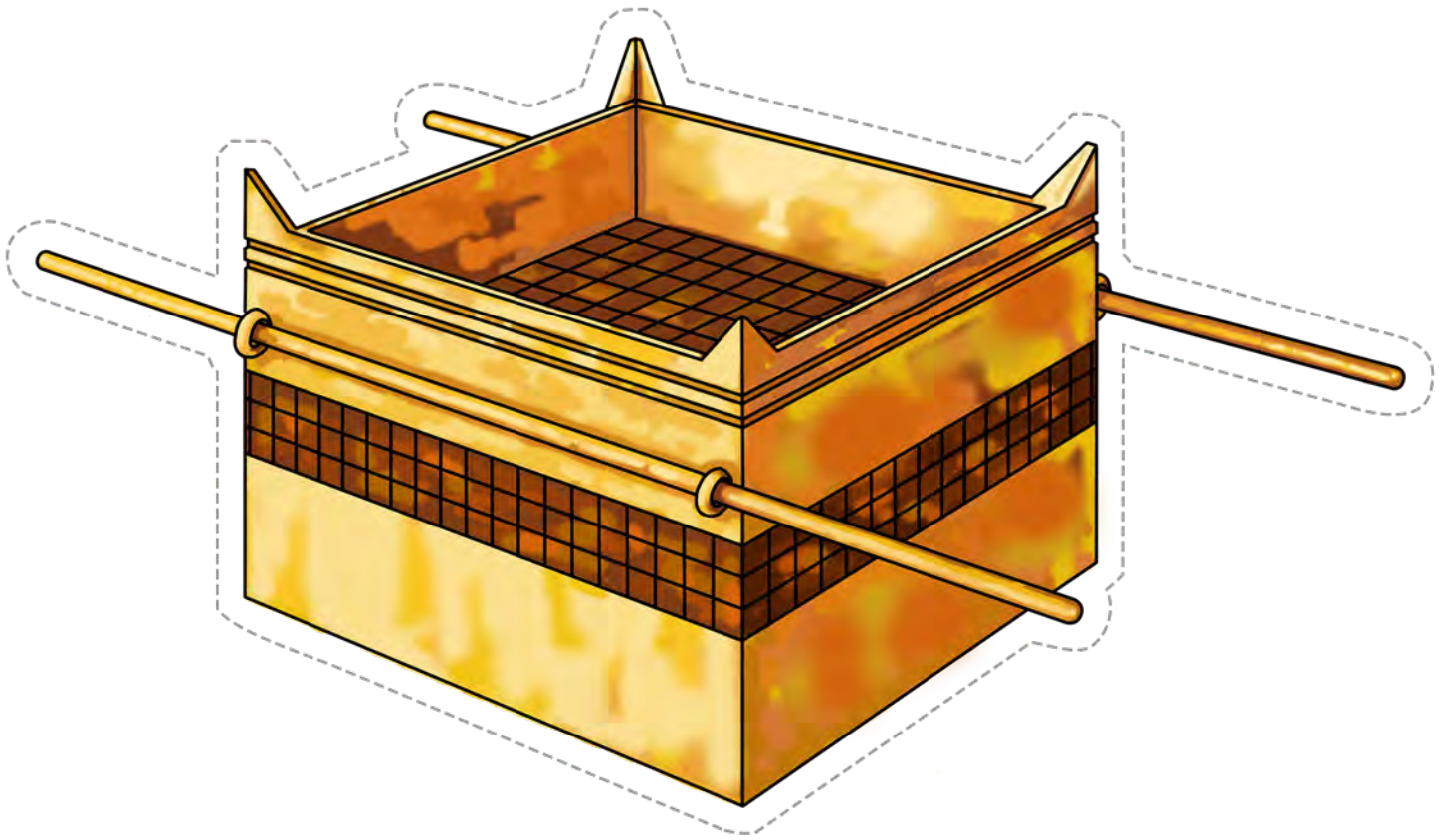

3-D CRAFT

Materials:

- Cardstock - white
- Lollipop sticks - white (2)
- Bronze paint (to paint lollipop sticks)
- Brush
- Double-sided tape
- Ruler
- Gorilla or Tacky glue
- Scissors
- Coloring pencils, crayons or markers
- Craft Templates: Bronze Altar A & B (BW) or C & D (color)
Bronze Basin E (BW) or F (color)

Parent/Teacher Preparation:

- Print Craft Templates of choice on white cardstock.

Furniture Pieces for the Courtyard

Exodus 27:1-8; 30:18

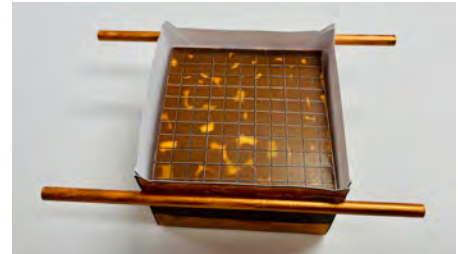
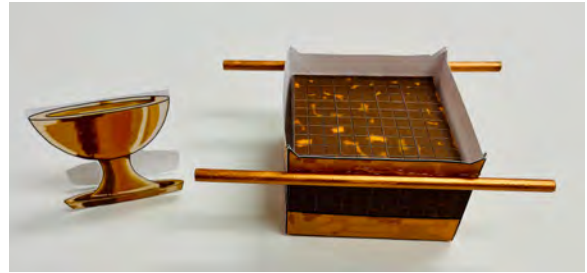

Instructions for the 3-D Craft:

- If using BW Templates, color using medium of choice.

Bronze Altar

- Cut out all Template pieces (P1)
- Using a craft paint brush and bronze paint, paint 2 white lollipop sticks and allow to dry. (P2a, P2b)
- Using a ruler to assist you, fold the tabs and lines on the altar. (P3a, P3b, P3c)
- Roll double-sided tape on the tabs of the altar. (P4)
- Start bringing in the long sides of the altar. (P5a, P5b)
- Connect the tabs on the short side of the altar to the tabs on the long side of the altar. (P6a, P6b, P6c)

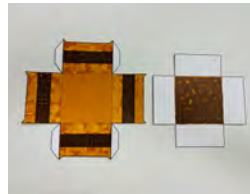

P1



P2a



P2b

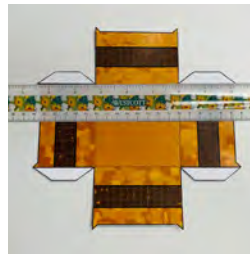

P3a

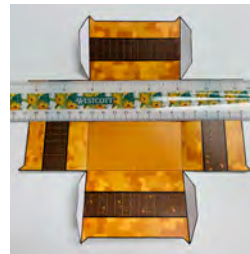

P3b



P3c

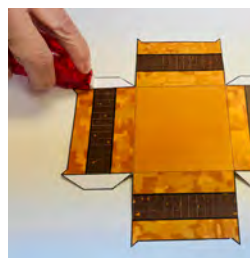

P4

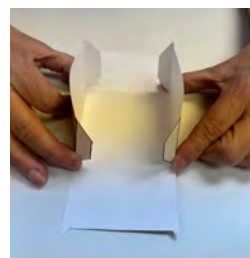

P5a

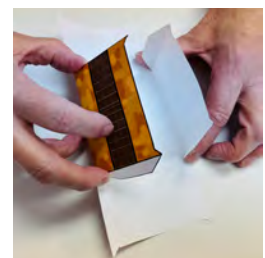

P5b



P6a



P6b



P6c

Instructions for the 3-D Craft Cont'd:

- Lay the altar aside for now.
- Using a ruler to assist you, fold the tabs on the grating. (P7a, P7b)
- Place the grating inside the altar. (P8)
- Spread a line of glue on one side of the bronze altar, just above the grating. Lay 1 bronze pole onto the glue. (P9a, P9b)
- Allow to dry and repeat the process for the opposite side. (P10a, P10b)
- Allow to dry.

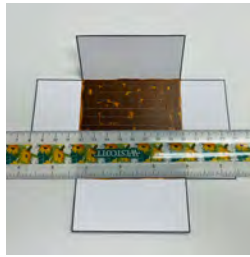

P7a

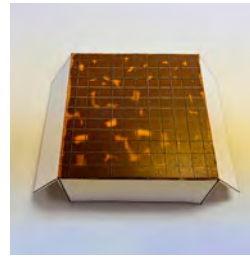

P7b



P8

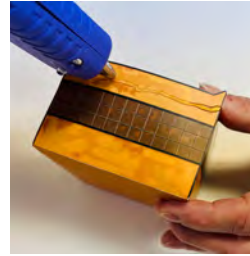

P9a



P9b

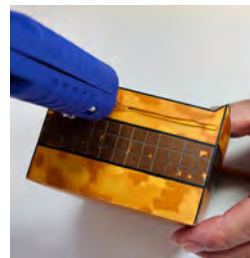

P10a



P10b

Bronze Basin

- Cut out the Bronze Basin piece. (P1)
- Using a ruler to assist you, fold the basin horizontally down the middle as well as the end tabs. (P2a, P2b)
- Roll double-sided tape on one of the tabs on the basin. (P3)
- Press firmly to connect the tabs. (P4)
- Your bronze basin is now complete and ready to stand up. (P5)



P1



P2a

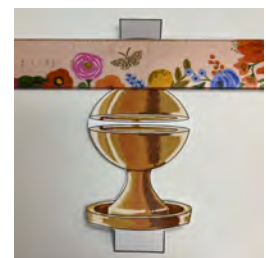

P2b

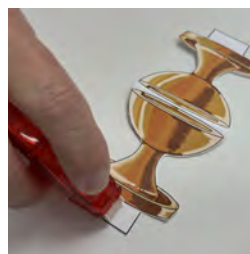

P3

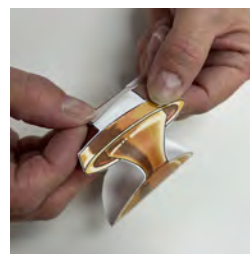

P4



P5

You now have a 3-D visual representation of the 2 furniture pieces in the courtyard.

Bronze Altar A (BW)

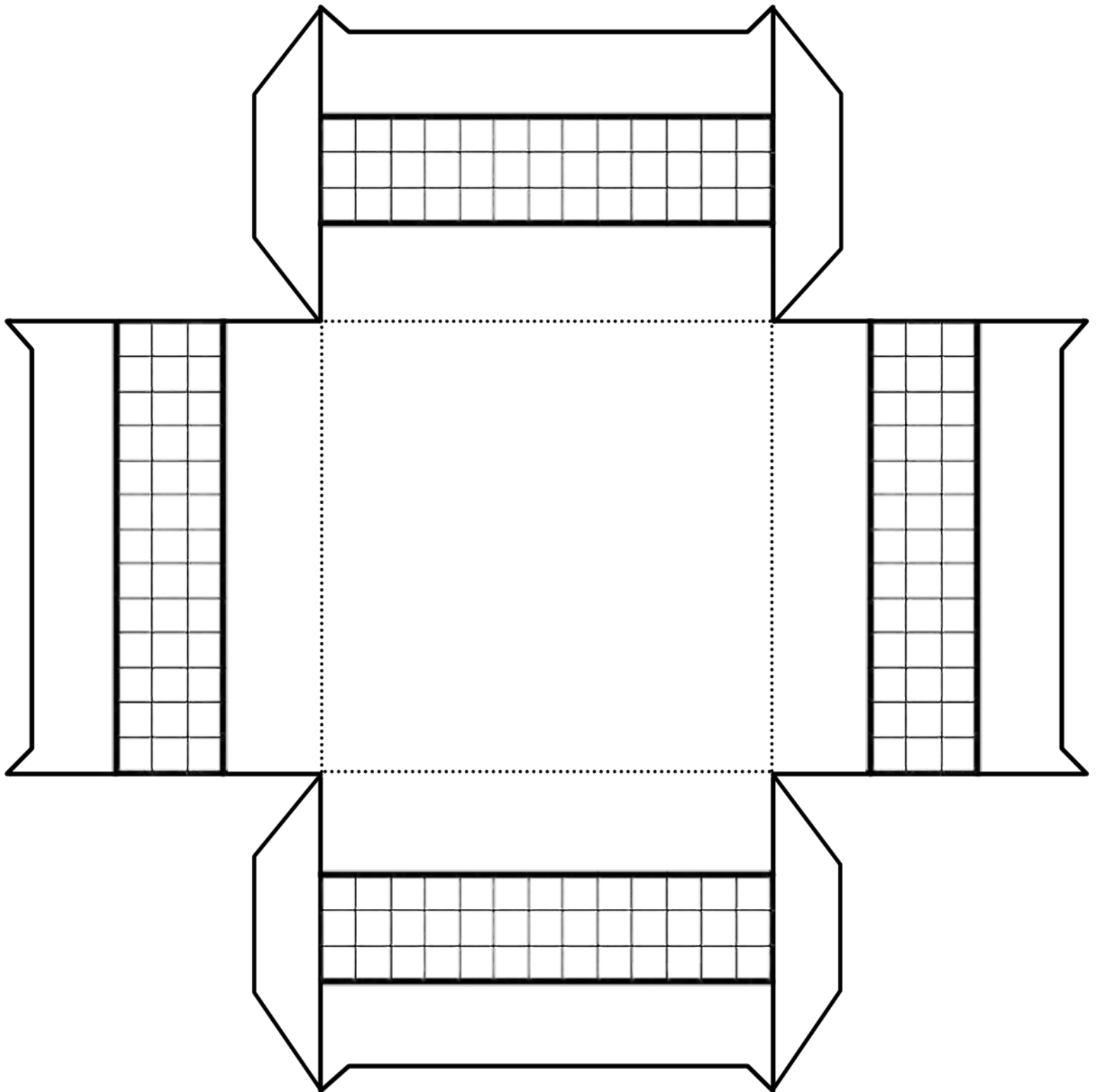

Bronze Altar B (BW)

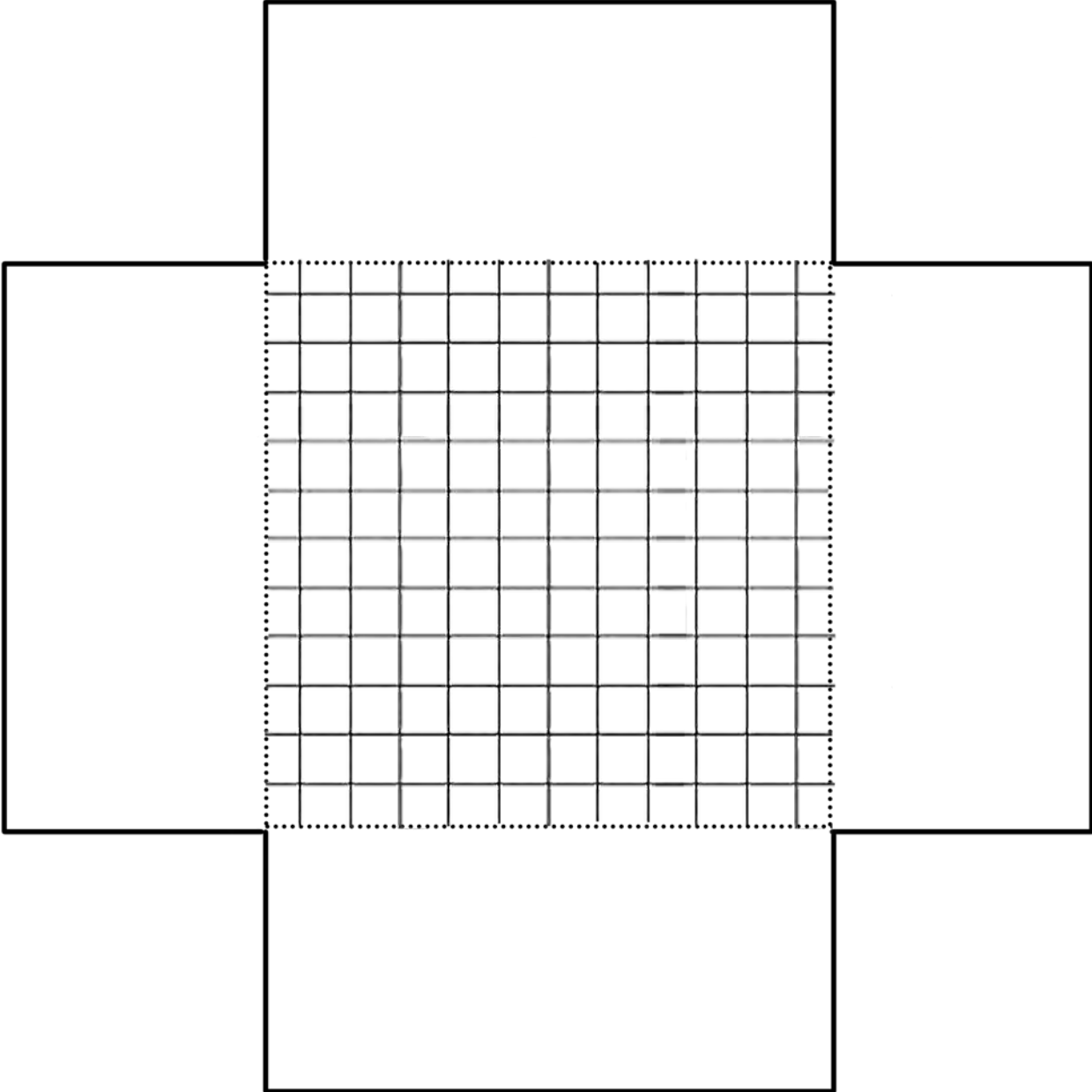

Bronze Altar C (color)

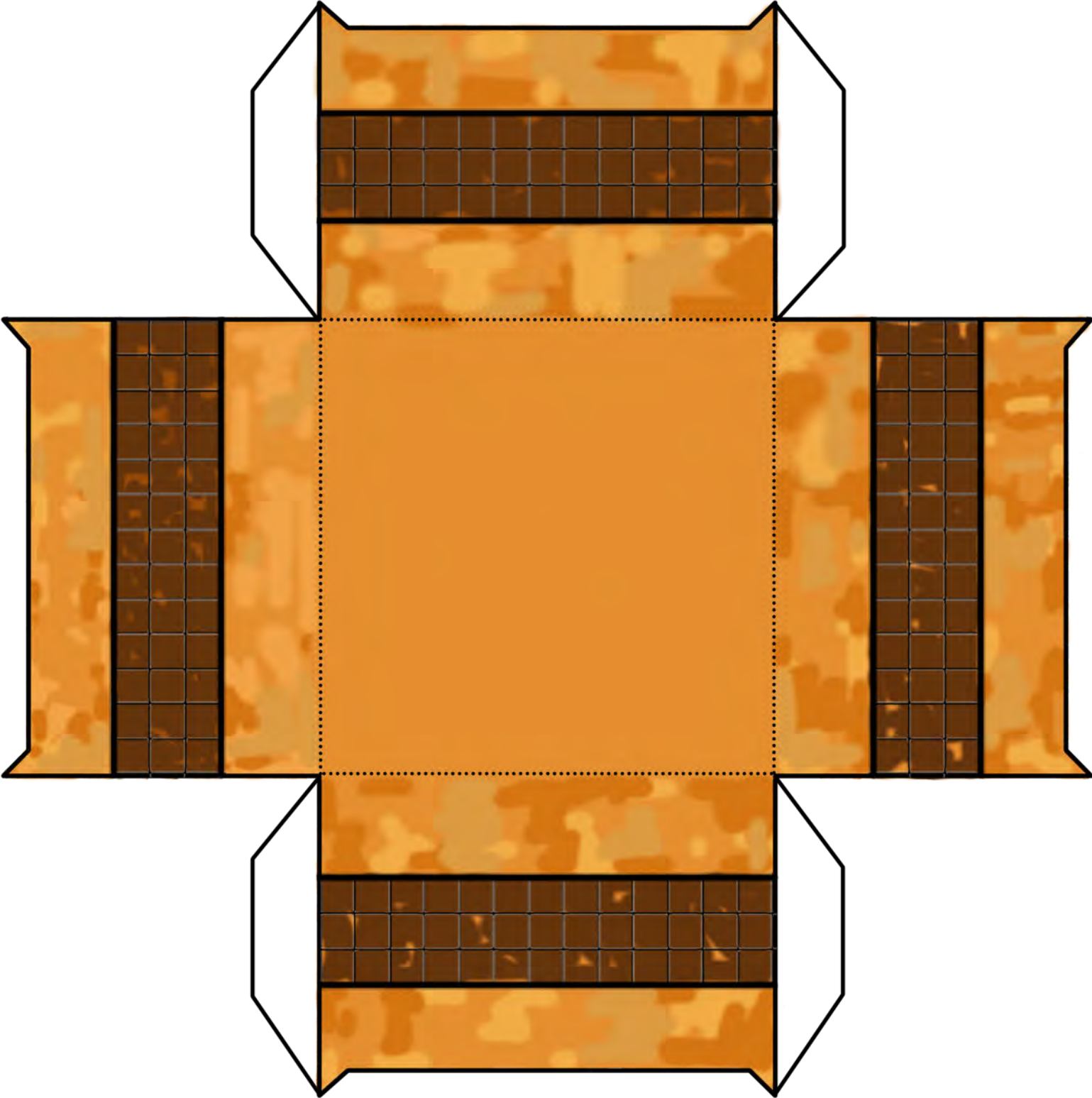

Bronze Altar D (color)

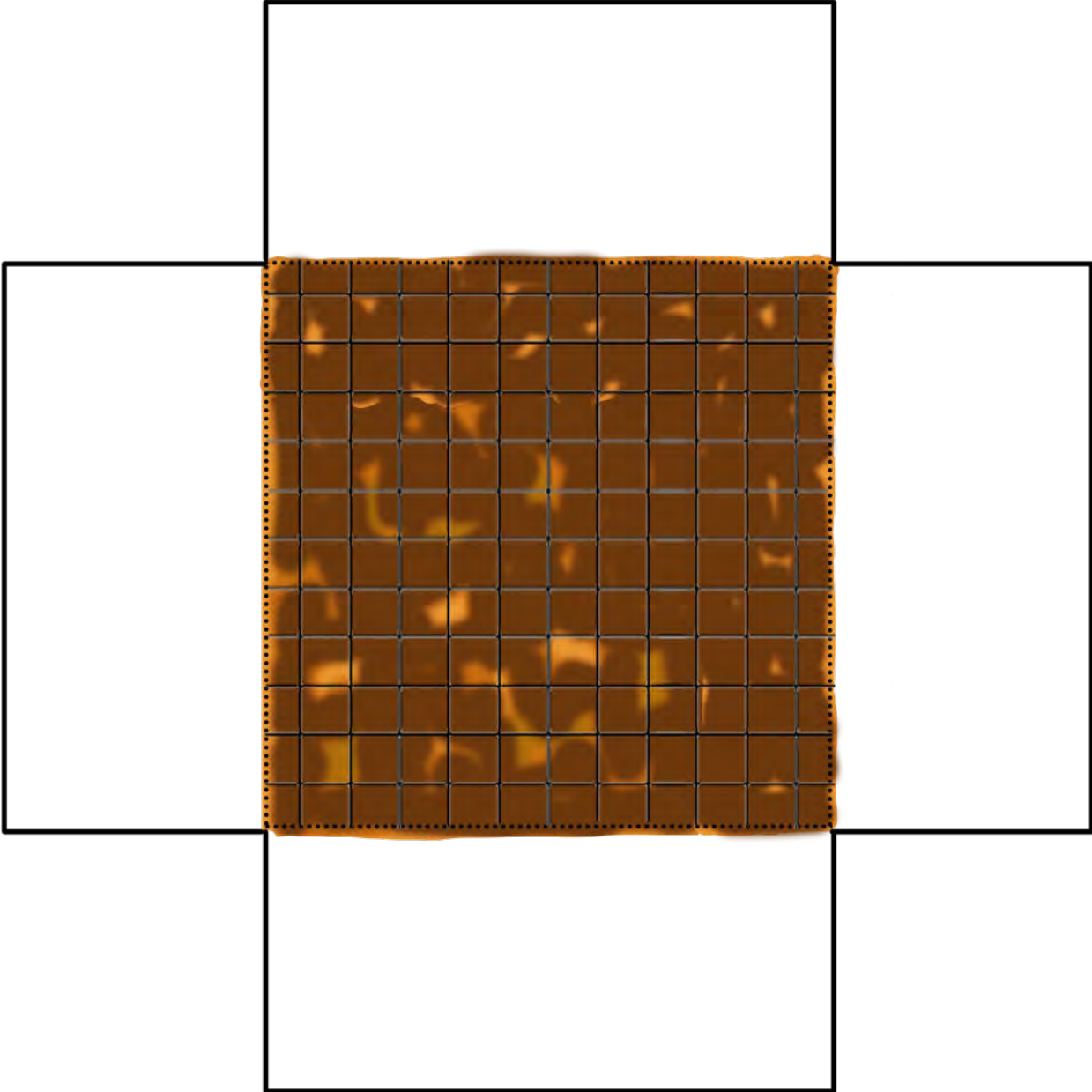

Bronze Basin E (BW)

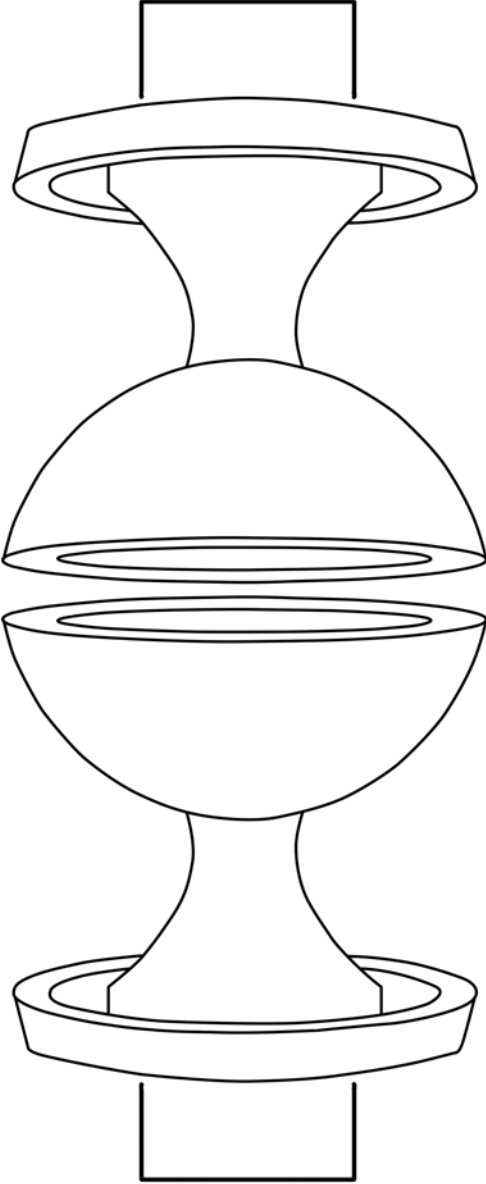

Bronze Basin F (color)

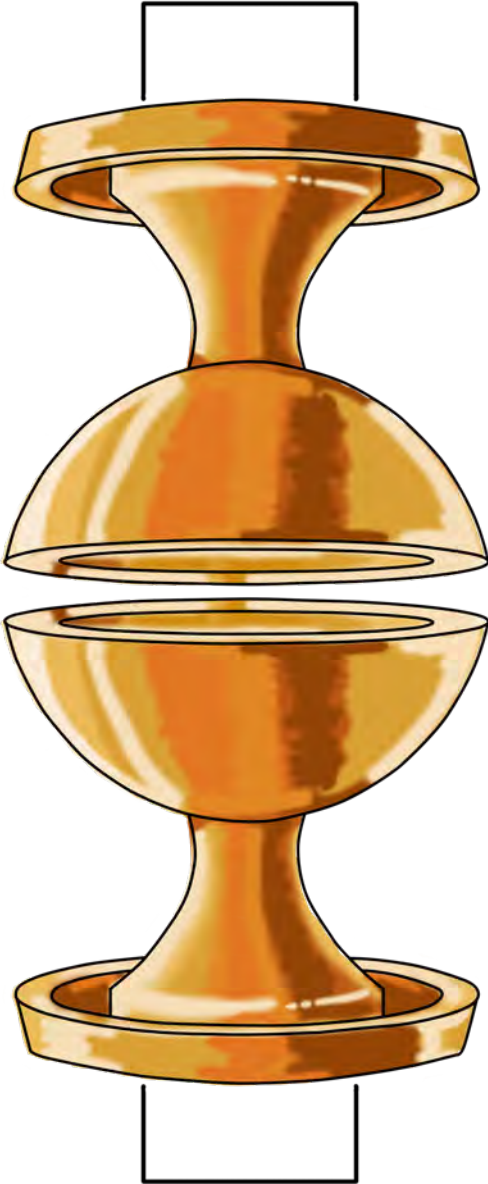

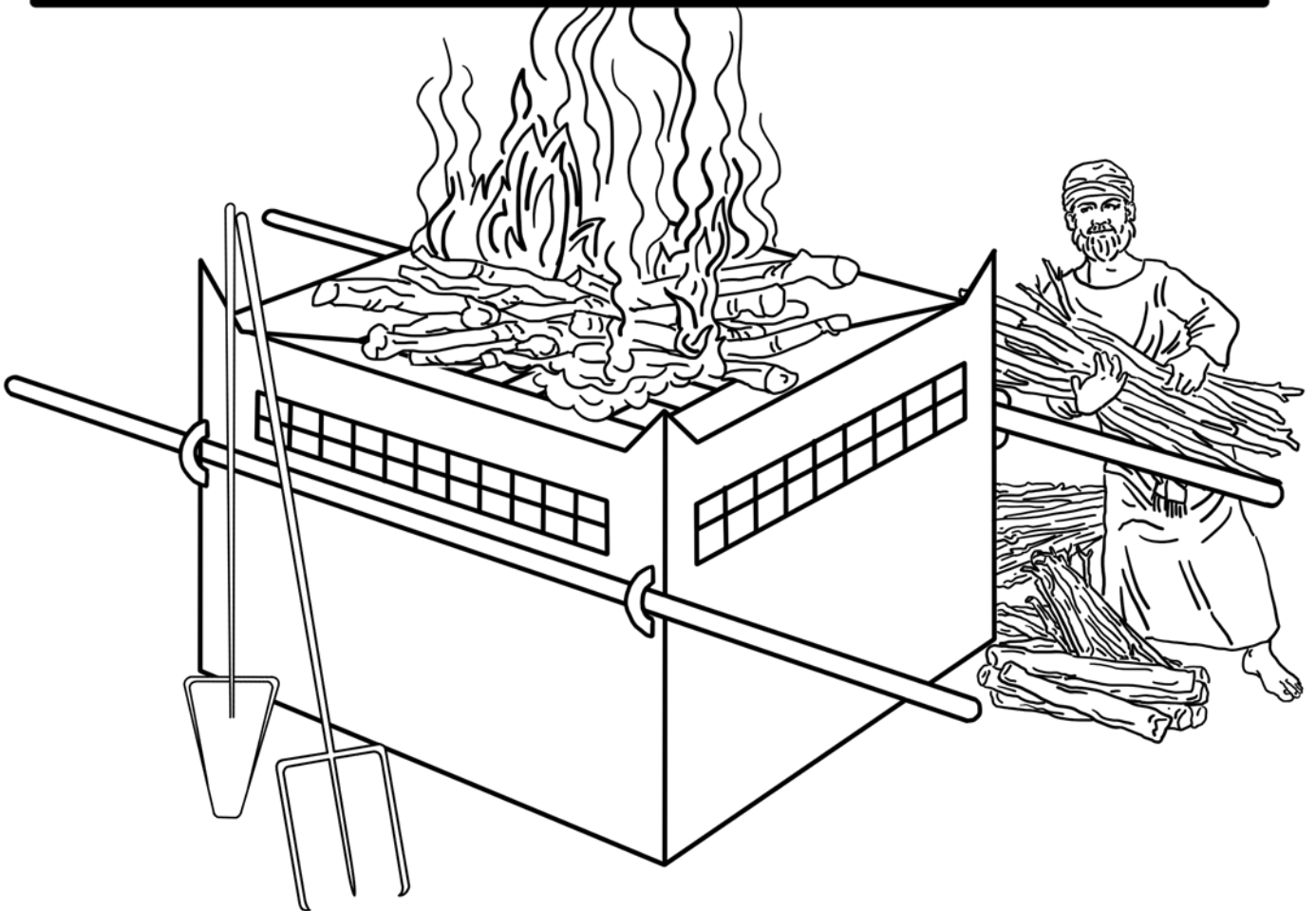

Sweetness of Torah

SWEET SOUNDS OF TORAH

(Sing Praises to His Name)

Here is the link for this song:

https://www.podomatic.com/podcasts/steveberkson/episodes/2023-03-03T13_00_00-08_00

The Bronze Basin

And you shall make a basin of bronze, of bronze
And put it between the Tent of Meeting and the altar
And Aharon and his sons shall wash from it their hands and feet
And it shall be a law forever to them and his seed

When they go into the Tent of Meeting and bring an offering
They'd wash their hands and their feet with water
And Aharon and his sons shall wash from it their hands and feet
And it shall be a law forever to them and his seed

And Aharon and his sons shall wash from it their hands and feet
And it shall be a law forever to them and his seed



SWEET TASTE OF TORAH

This snack relates to this week's parsha. Please take these as suggestions and make necessary changes based on your individual dietary needs.

Bronze Altar

Exodus 27:1-2 & 38:1-2



Ingredients:

- Square cookies - approx. 8-10 (represents the altar)
- Red frosting (represents the flames)
- 4 cashews (represents the horns)
- Animal cracker (represents the sacrificial animal)

Instructions:

Place the square cookies on top of each other to create the altar. Then pipe some red frosting in the center to create the fire flames. Place the cashews in the corners standing them upright and lay the animal cracker on the flames.

Next Week's Treasure Hunt

Next Week's Torah Portion

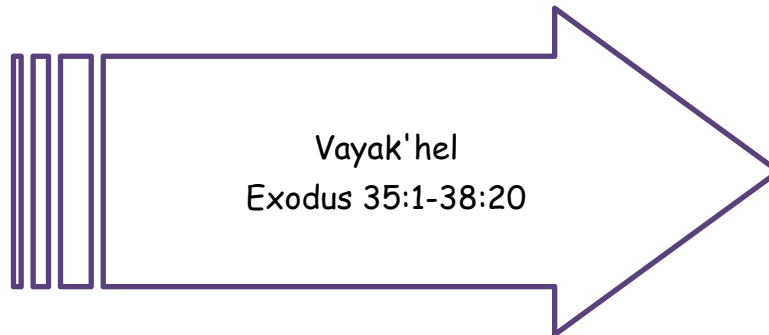

Suggested Reading Schedule

Monday:	Ex. 35:1-29	Sabbath instructions; Contributions for the tabernacle
Tuesday:	Ex. 35:30-36:7	Introducing Betsal'el and Oholiab
Wednesday:	Ex. 36:8-38	Curtains, coverings, boards, veil, columns for the Dwelling Place
Thursday:	Ex. 37:1-29	Making the ark, the table of showbread, lampstand, altar of incense, the anointing oil and incense
Friday:	Ex. 38:1-20	Making the bronze altar, the bronze basin and the courtyard