

# Vayak'hel

"He assembled"

Exodus 35:1 - 38:20

Katan Aleph



In This Edition:

22.1 - Wise Hearted Worker Bees

Exodus 25:1-7; 31:1-11; 35:4-35; 36:1-7; 37:1-29; 38



---

# Table of Contents

---

Parsha Pearls is a comprehensive resource that allows for complete customization by the parent. We understand that if you were to strive to accomplish all aspects of each lesson in one day it would be unrealistic and also overload for the child. It is our intention that this be used 'a la carte' so that it suits your specific needs. Our site caters to printing only the pieces you choose.

This page will provide quick links to get to the portion of the document for which you are looking. When you hover over the title a finger will appear. Click on it and you will be taken directly to that page.

If you are new to Parsha Pearls, we have created an [Introduction](#) document outlining how to use our lessons, as well as a [Scriptural Inspiration](#) document, which explains our titles and the Scriptural inspiration for them. We pray that Parsha Pearls blesses your home and that your children will grow to love the Word and to never depart from keeping Torah. As always, feel free to email us at [parshapearls@mtoi.org](mailto:parshapearls@mtoi.org) if you have any questions.

<b>Gem Seeking</b> (The Main Lesson) . . . . .	<b>3</b>
➤ Little Gems Story (Story for Younger Children)	3
➤ Little Gems Story Characters	6
<b>Counting What You Gained</b> (Worksheets) . . . . .	<b>18</b>
➤ Storing Up Treasure in My Heart (Memory Verse)	18
➤ Seeking Treasure (Questions from the Parsha)	20
➤ Word Search	21
➤ Maze	22
<b>Precious Possessions</b> (Arts & Crafts) . . . . .	<b>23</b>
➤ Craft	23
➤ Coloring Page	29
<b>Sweetness of Torah</b> . . . . .	<b>30</b>
➤ Sweet Sounds of Torah (Song Corresponding to the Parsha)	30
➤ Sweet Taste of Torah (Snack Corresponding to the Parsha)	31
<b>Next Week's Treasure Hunt</b> (Looking Ahead to Next Week's Parsha) . . . . .	<b>32</b>



# Gem Seeking

## LITTLE GEMS STORY

### Parent/Teacher Preparation:

Please see the [Instructions for the Little Gems Story](#) on the YMTOI website. This will help you to understand how to prepare for the story.

### Wise Hearted Worker Bees

Shalom, children! Here we are at the very end of the book of Exodus. Mosheh is going over all the wonderful things Yahweh has told him about how to make His Dwelling Place. Who remembers how Mosheh got all the materials to make Yahweh's Tent of Meeting? Yes, Yahweh told him to ask the people to give whatever their hearts wanted to give. **(Place contribution scene on board.)** Have you ever felt really happy after you gave something really nice to someone you love? Well, many of the people of Yisra'el must have been jumping for joy, because the Bible tells us that they gave Him everything He needed for His house. Do you think maybe they were excited that Yahweh was going to come and live right there with them? In a moment we'll see just how much fun they had.

Of course, Yahweh wanted many different things to build His special Place. Let's see how many we can remember. Hmm... Gold and silver, yes, and bronze, too! **(Place gold, silver and bronze on board.)** It all must have been very heavy to carry. The women helped too, by bringing piles and piles of their jewelry - rings and earrings, nose rings and necklaces. **(Place jewelry pile on board.)**

What else? How about the coverings that went over the top? There was fine linen, **(place linen roll on board)** and material in 3 royal colors. Can anyone tell me what they were? Yes, there was red, blue and purple material, to decorate the fine linen for those gorgeous curtains, and for the veils, too. **(Place 3 fabric rolls on board.)** What about coverings that came from animals, like goats' hair, and rams' skins dyed red, and fine, sturdy leather? **(Place 3 coverings on board.)**

Let's go on. What kind of wood did Yahweh ask for, to build the planks for the walls, and all the furniture? **(Place acacia wood on board.)** It begins with an 'A'. Yes, very good! It was acacia wood, taken from small trees that grew all over the wilderness. **(Place acacia tree on board.)** And of course, Yahweh wanted all the wooden items to be overlaid with gold, and some with bronze. **(Place gold and bronze boards on board.)**

Another thing that was important to Him was pure olive oil, to keep the lampstand burning, and all kinds of spices for the anointing oil and for the sweet incense that was to be burned on the altar inside the Set-apart Place. **(Place spices on board.)** Oh, I almost forgot the gemstones. **(Place gemstones on board.)** These were to be set in the High Priest's shoulder garments and breastplate. **(Place breastplate and shoulder garment on board.)**



Jewels are so beautiful, aren't they? And these must have been big, shiny, sparkly ones, don't you think? The rulers among the people brought most of those, because gems are rare and expensive. **(Place gem scene on board.)**

Let's look at what they used the gold, silver and bronze metals for. The boards of the Dwelling Place were overlaid with gold **(place Dwelling Place frame on board)**, as well as the ark of the Witness, the table of showbread and the altar of incense. Did you know that the 7-branch lampstand, the lid of atonement, and its kerubim, was solid gold? **(Place ark, menorah, table and incense altar on board.)** The utensils for the lampstand and the table of showbread were also made from gold. **(Place utensils on board.)** Silver was used to make the hooks and bands on the columns in the courtyard as well as the sockets of silver that the boards rested on. **(Place column on board and point to silver parts on it as well as the Dwelling Place sockets.)** Perhaps the heaviest pile of metals was the bronze pile. The big wash basin and its stand were solid bronze, and the altar for burnt offerings was also overlaid with bronze, **(place bronze altar and wash basin on board)** as well as all the utensils for the altar. **(Place bronze utensils on board.)** Children, did you know that the basin was made from bronze mirrors? **(Place bronze mirror on board.)** There were sockets of bronze, too on the columns, and just think of all the bronze tent pegs they needed to hold down the Dwelling Place and the large courtyard all around it! **(Place bronze tent peg on board.)**

Now, let's meet 2 amazing men who had a huge part in making all this. Their names are Betsal'el and Oholiab, and they were appointed to oversee all the work. **(Place Betsal'el and Oholiab on board.)** When the hearts of the people of Yisra'el were moved to bring their materials for the Tent, do you think they dumped them all at Mosheh's feet? No way! He was far too busy listening to Yahweh to handle all that! It was Betsal'el and Oholiab who collected the stuff to make the Set-apart Place. But you see, they had a small problem. The people were having so much fun giving their precious things to Yahweh that Betsal'el and Oholiab had to come and beg Mosheh to get the people to stop, because they had more piles of stuff than they knew what to do with - more than enough to complete the work! Mosheh had to tell the people to stop bringing anymore contributions for the Set-apart Place. They had too much already! **(Place Mosheh telling people to stop scene on board.)**

Now, do you think that these 2 overseers did all the work themselves? I don't think so! And those who wanted to help all came to work. The Scriptures say that Yahweh had given loads of talent and skill to many of the children of Yisra'el, to make beautiful things and that some of the people were 'wise-hearted.' That means they had exactly the kind of talents needed to build and decorate His Dwelling Place. The Scriptures also tell us that 'wise-hearted' women spun yarn. **(Place woman spinning yarn on board.)** What do you think that was used for?

Are any of you good at drawing and coloring and making crafts? How about figuring things out and putting things together, like Legos? **(Place Lego blocks on board.)** Some of you may like to sing or play an instrument, or do sports. **(Place singer on board.)** Building stuff with your hands might not be your thing. You see, each of us has special abilities that we can give to Yahweh.



Yahweh Himself picked our friends Betsal'el and Oholiab to be over this busy bunch of worker bees! You can hardly imagine how much talent Yahweh had given these 2 men. They had wisdom and understanding in all the skills, and were able to do anything and everything that was needed for the Dwelling Place. Do you ever watch someone do something really cool and wish you could do it, too? Well, because there was so much to do, Betsal'el and Oholiab had to be good at teaching others to make the same cool stuff they could make. Betsal'el was a designer of anything beautiful. He could design using metals, and he could cut fine gemstones, do carpentry and carve wood. **(Remove Betsal'el and place Betsal'el working with gold and wood on board.)** Oholiab was also an excellent designer, and especially good at weaving and embroidering. He could set gemstones and then use sharp tools to write neatly on them. He could also do this with metals, and make everything look really fancy. **(Remove Oholiab and place Oholiab working with loom and engraving gems on board.)**

These 2 guys and their helpers made all the furniture: the ark of the Witness, with its golden lid of atonement and the kerubim, and its rings and poles. **(Point to the ark on board.)** For the Set-apart Place, they made the table for the showbread, the lampstand and the altar of incense. **(Point to utensils.)** They made the rings and poles to carry them, too, and also all their utensils. **(Place utensils on board.)** They made the courtyard and its screens, along with the altar of burnt offering, the bronze basin and the stand it was set upon, plus all their utensils. **(Place courtyard scene on board.)**

Is your head swimming yet from thinking about all these parts of the Dwelling Place? Yahweh wants us to know that each part is important. Oh, one more thing - they made that breath-taking linen suit for the high priest, with its robe, its turban, its breastplate and shoulder pieces set with gemstones. We can only imagine exactly how amazing it looked - Aharon's one-of-a-kind dress-up suit, all for the pleasure of Yahweh!

**(Place Aharon in priestly garments on board.)**

Yahweh was very happy with the children of Yisra'el because they did everything that Yahweh had commanded Mosheh to do. Because of all the gifts the people had brought to Him, and the work they had done, His Dwelling Place was all finished - every single piece! It was exactly the way He had shown to Mosheh. Yahweh's heart was so filled with love and joy that He had Mosheh speak a special blessing over His people. **(Place Yisra'elite family on board.)**

Children, if we give Yahweh our best with a generous heart just like the children of Yisra'el did in their contributions and the work of their hands, He will give us a bigger blessing than the temporary Dwelling Place - we will get to live in His forever Kingdom with Him. Doesn't that sound wonderful? **(Allow children to answer.)**

Now that the children of Yisra'el have all the pieces ready to make the Dwelling Place, it's time for them to put it all together. We'll have to wait and find out about that another time.

Well children, we have come to the end of our story for today. We will see you next week for another exciting Little Gems story!



Contribution scene



Singer

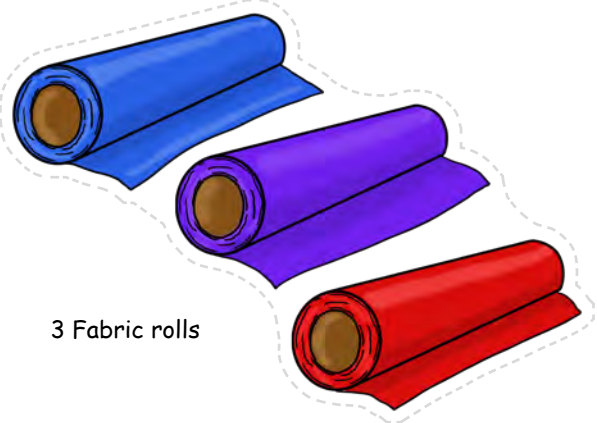

3 Fabric rolls

3 Coverings

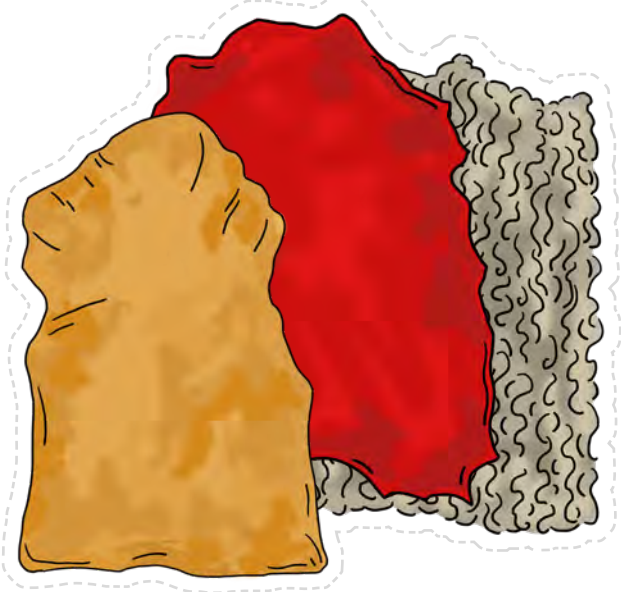

Acacia wood



Acacia tree



Gold and bronze boards



Spices



Gemstones



Ark, menorah, table and incense altar

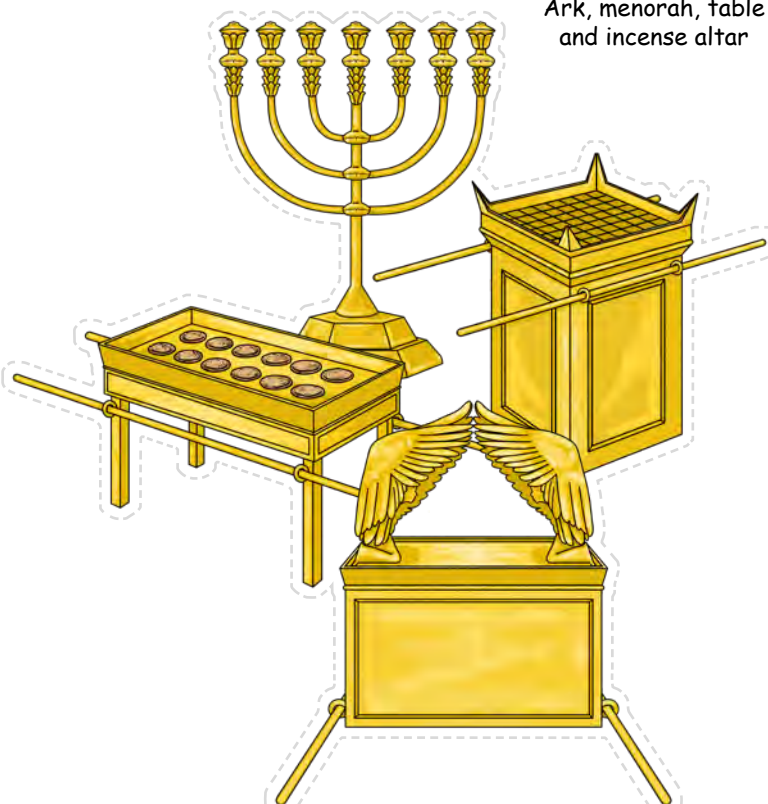

Breastplate and shoulder garment

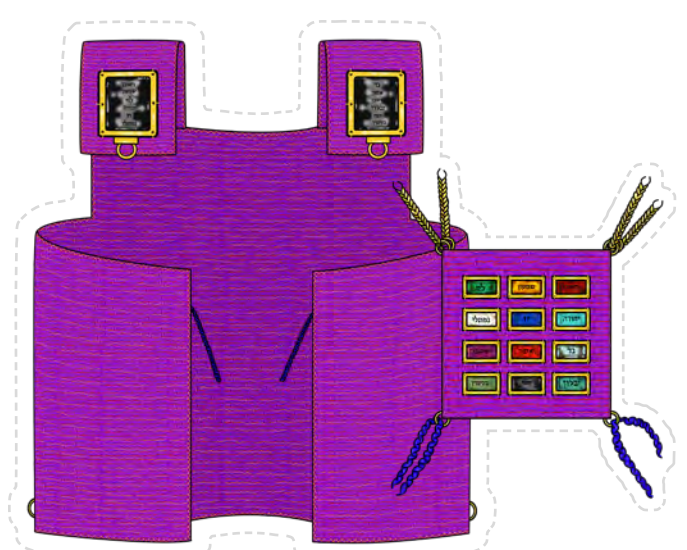

Utensils

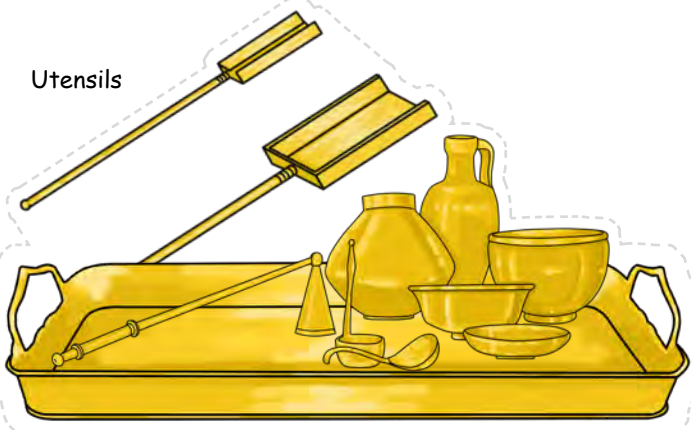

Gem scene



Bronze altar and wash basin

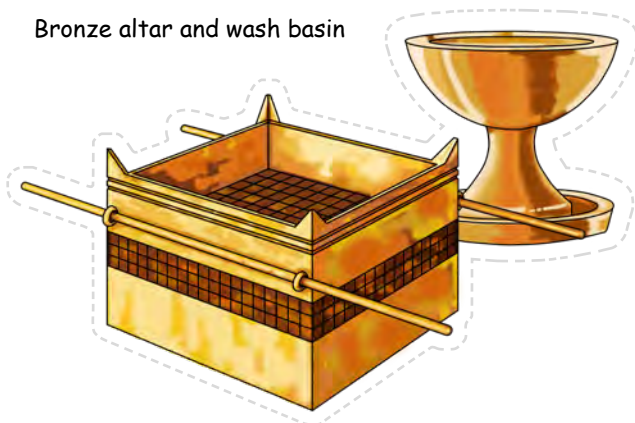

Dwelling Place frame

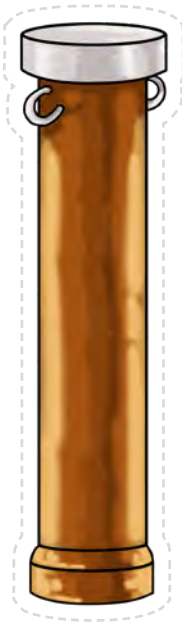
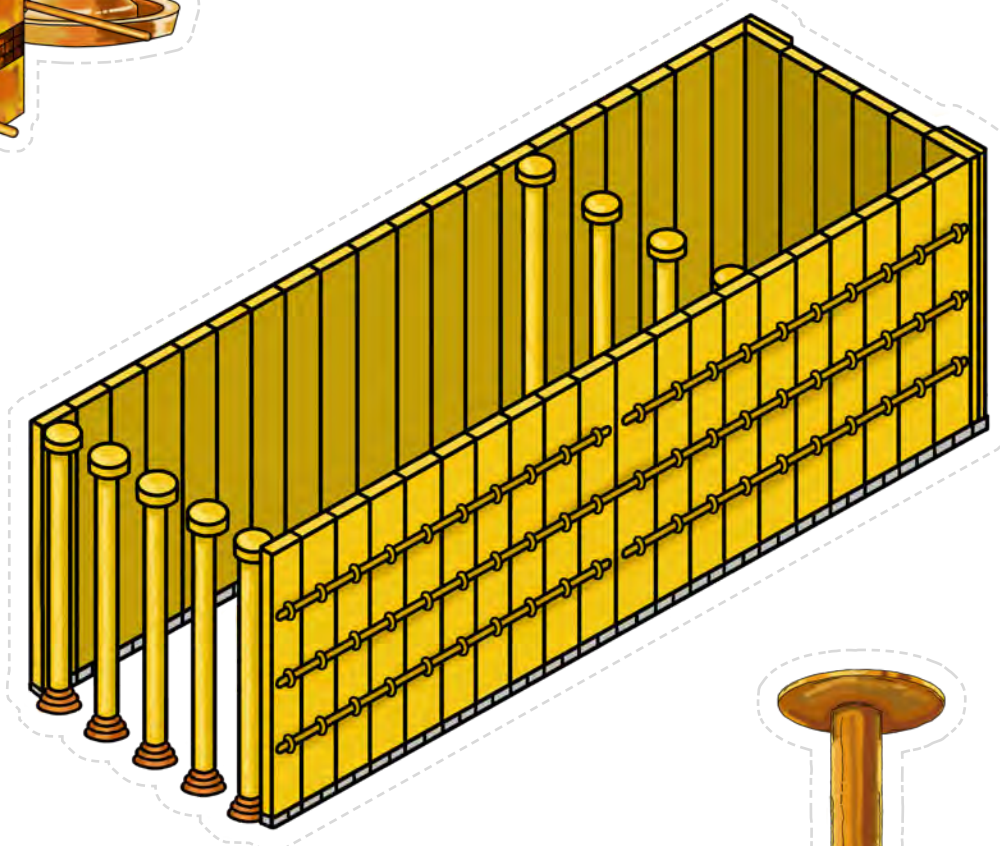

Column



Bronze tent peg



Bronze utensils



Bronze mirror



Betsal'el



Oholiab



Jewelry pile

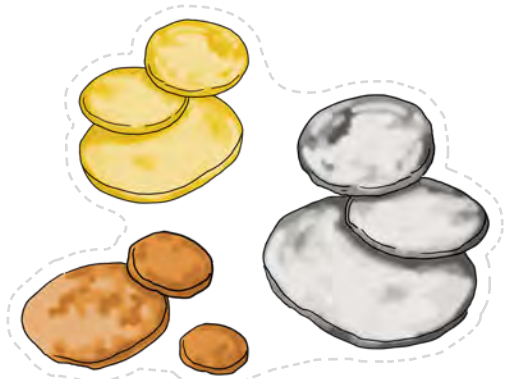

Gold, silver and bronze



Woman spinning yarn

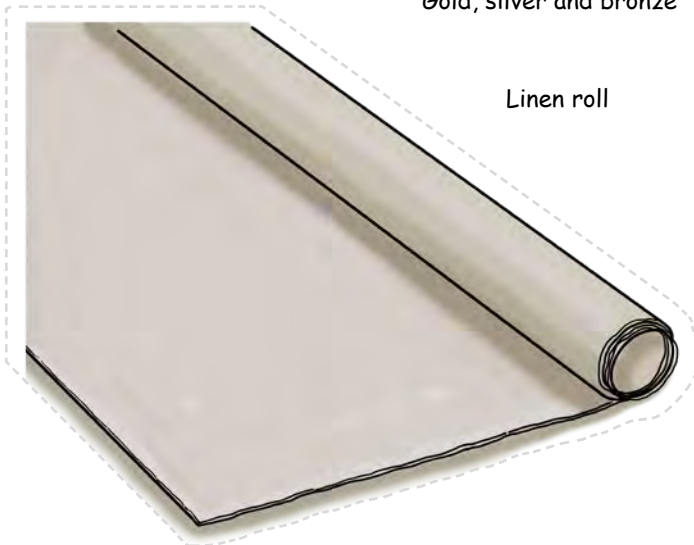

Linen roll



Betsal'el working with gold and wood

Oholiab working with loom and engraving gems



Yisra'elite family

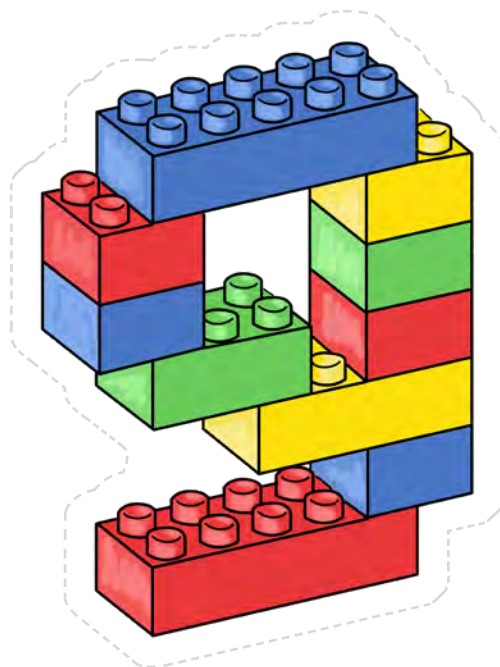

Lego blocks



Aharon in priestly garments



Mosheh telling people to stop scene

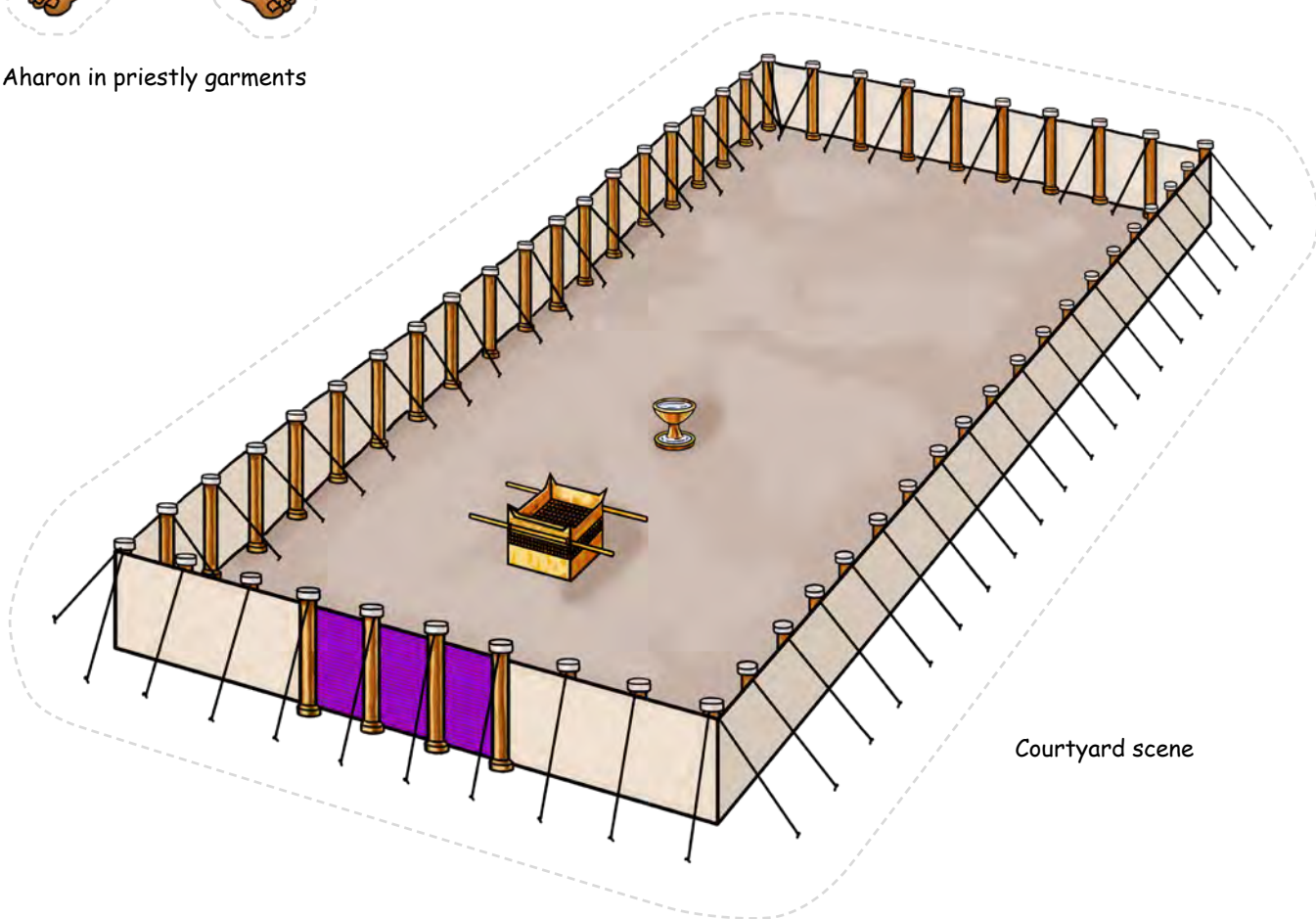

Courtyard scene

Contribution scene

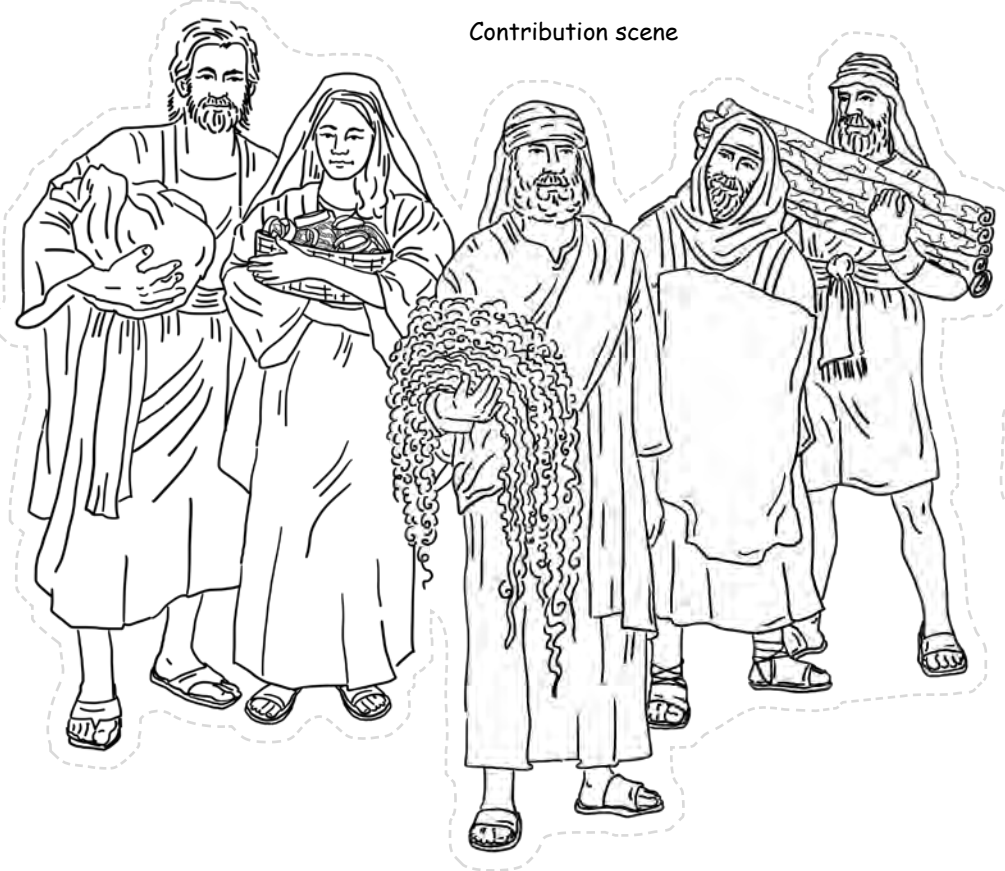

Singer

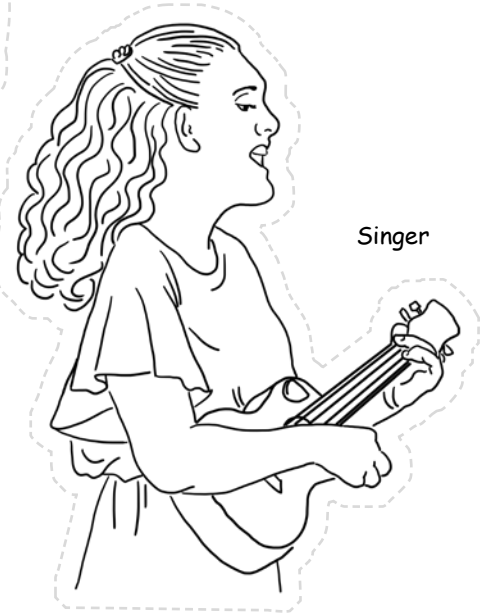

3 Fabric rolls

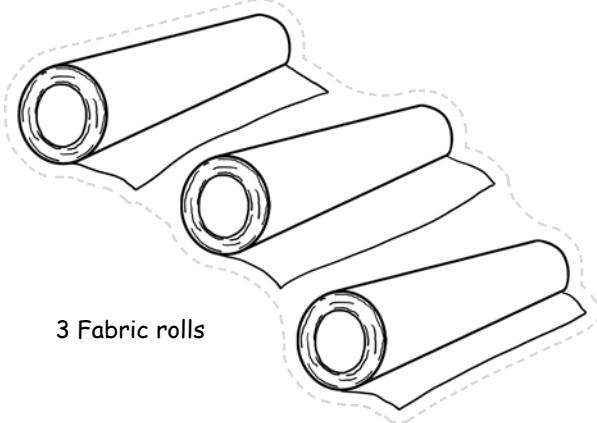

3 Coverings

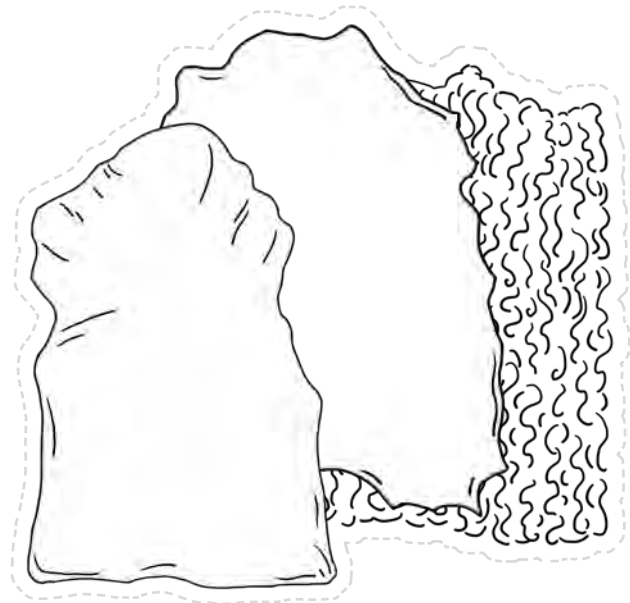

Acacia wood

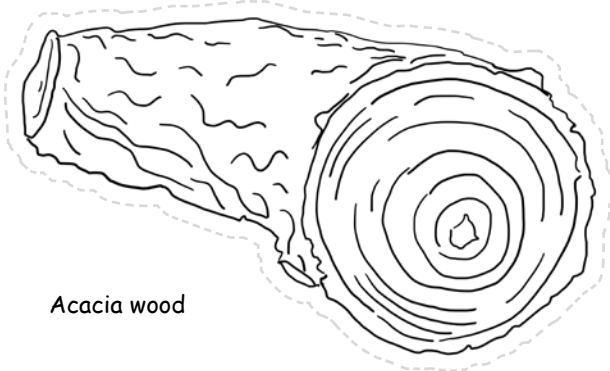

Acacia tree

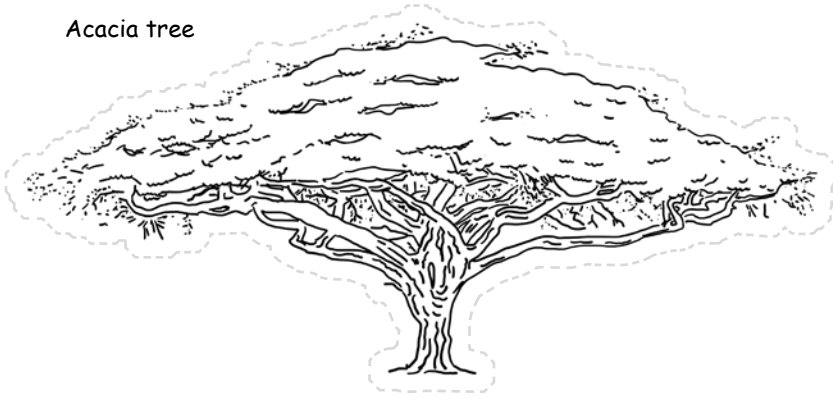

Gold and bronze boards

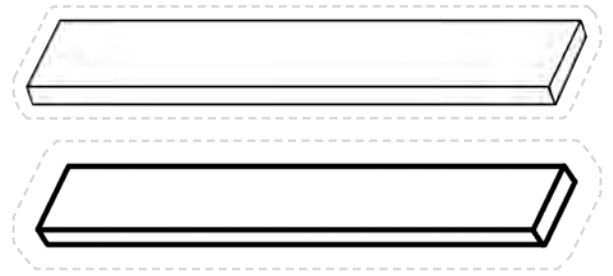

Spices



Gemstones

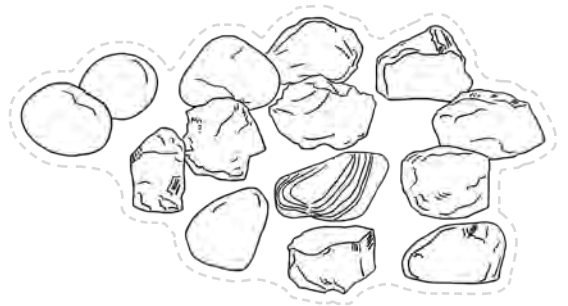

Ark, menorah, table and incense altar

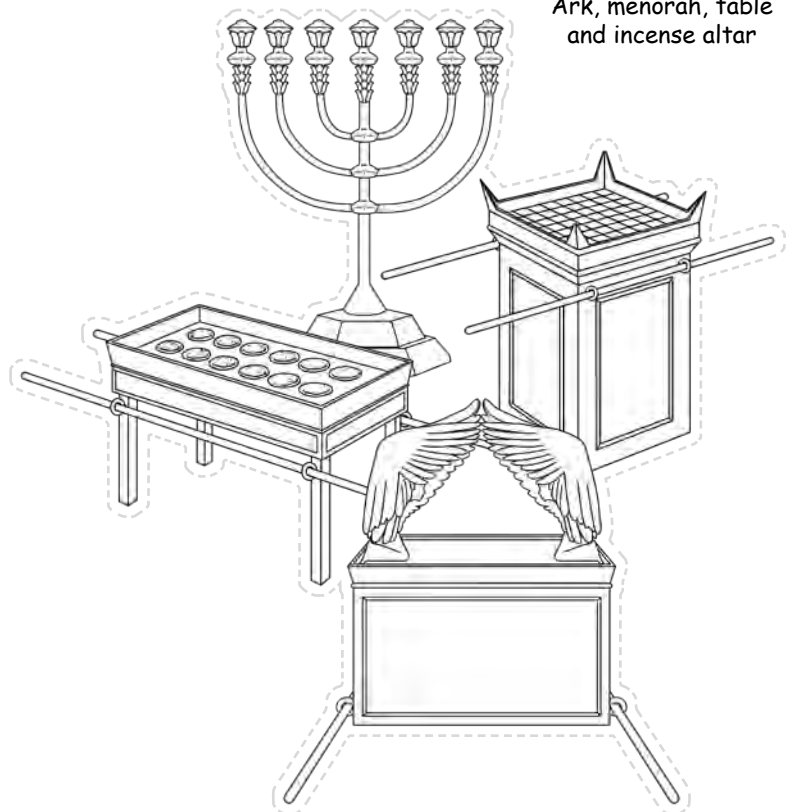

Breastplate and shoulder garment

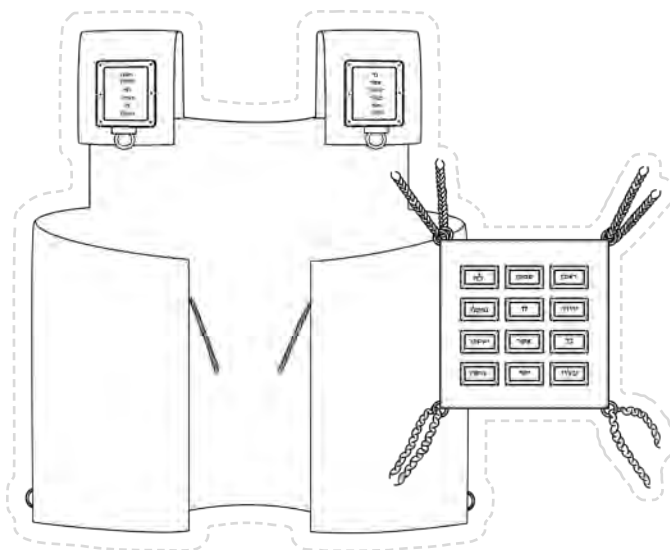

Utensils

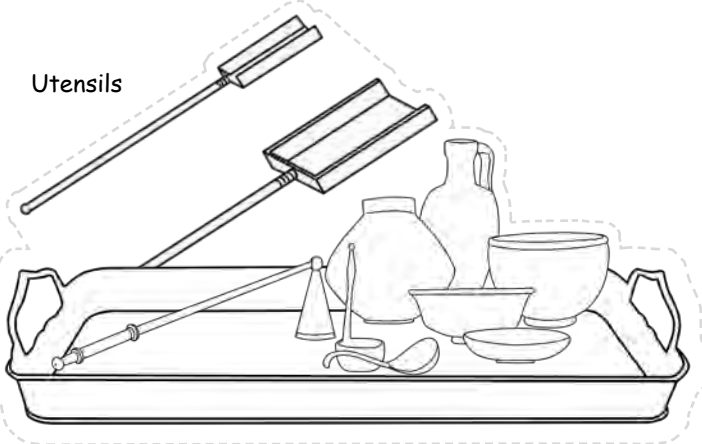

Gem scene

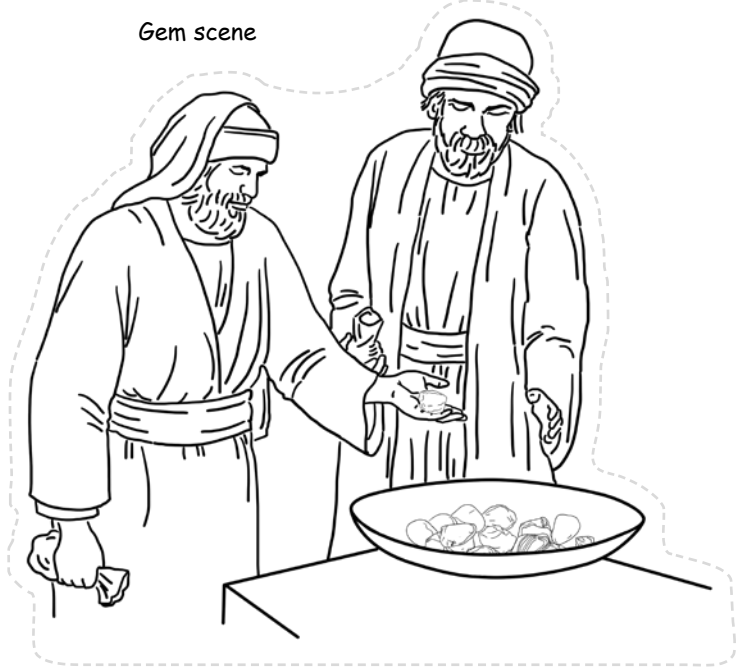

Bronze altar and wash basin

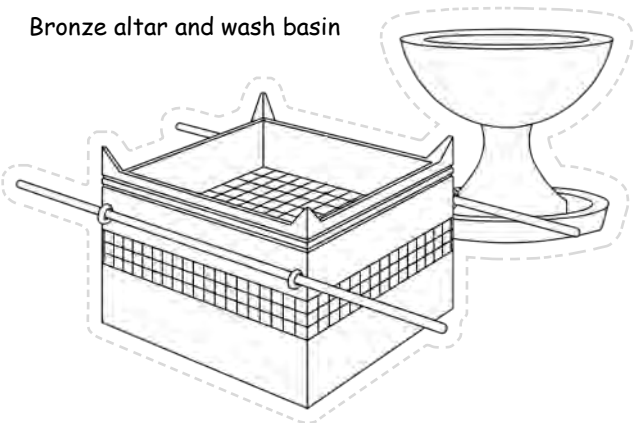

Dwelling Place frame

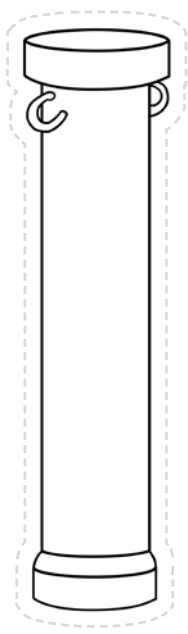
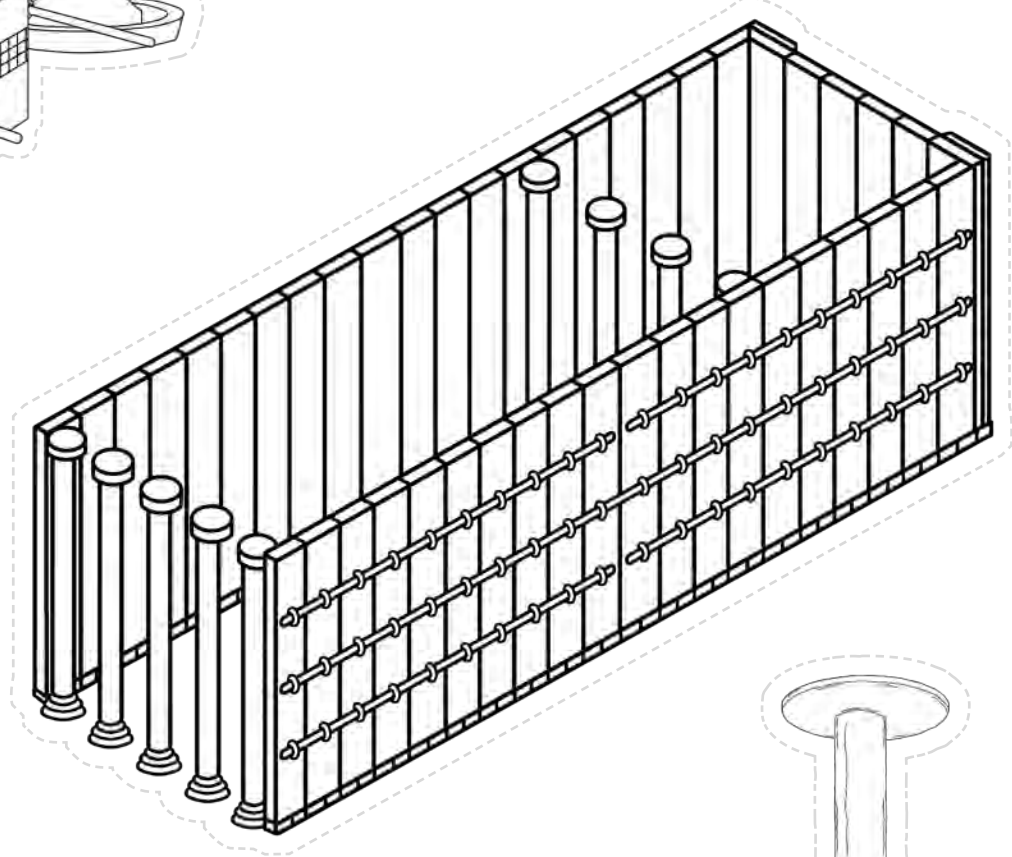

Column

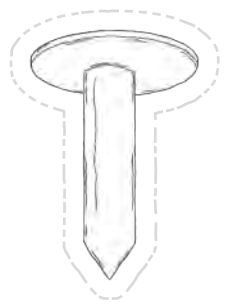

Bronze tent peg



Bronze utensils



Bronze mirror

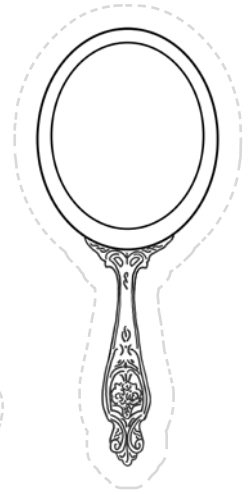

Betsal'el



Oholiab



Jewelry pile

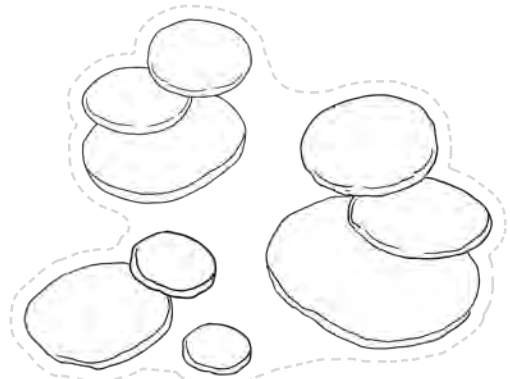

Gold, silver and bronze



Woman spinning yarn

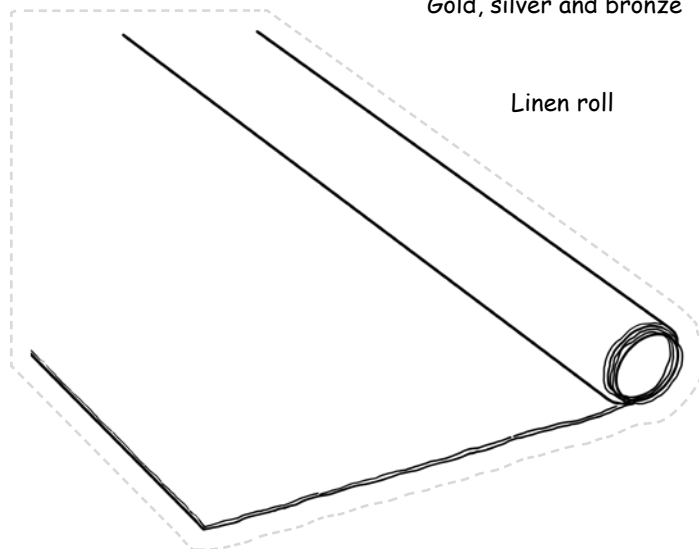

Linen roll

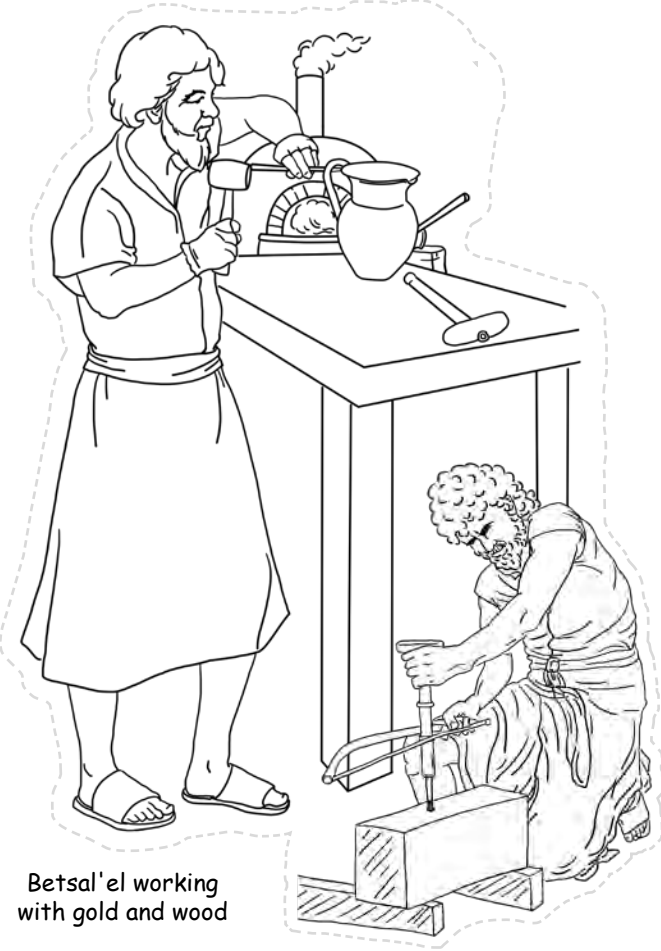

Betsal'el working with gold and wood

Oholiab working with loom and engraving gems

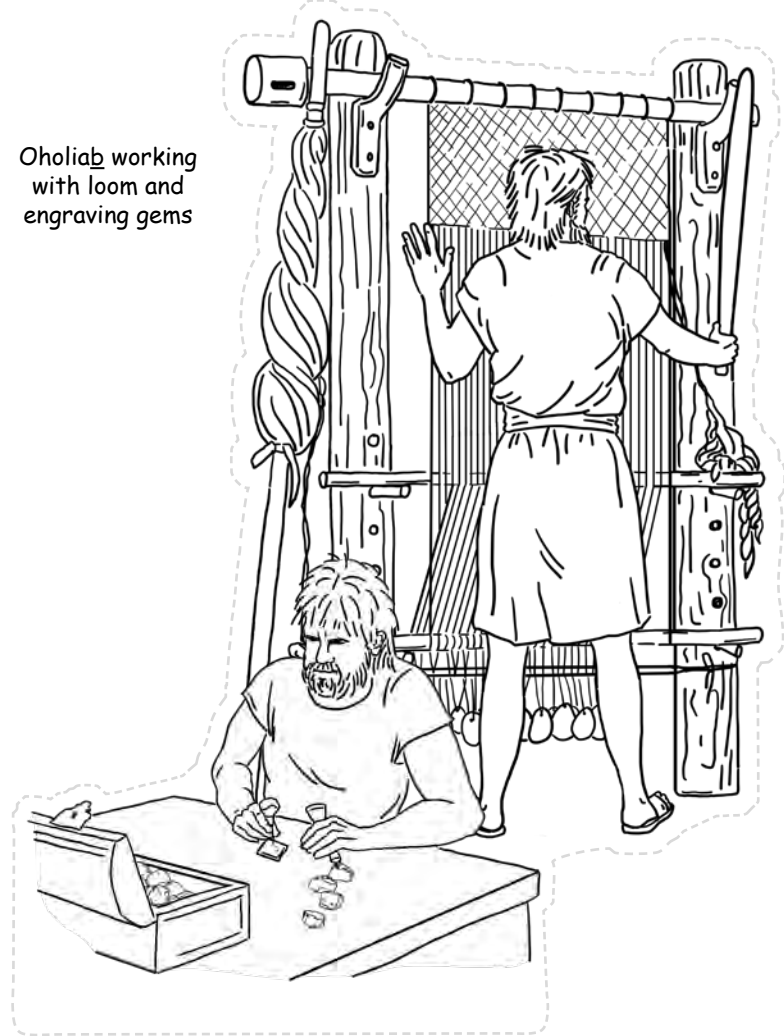

Yisra'elite family

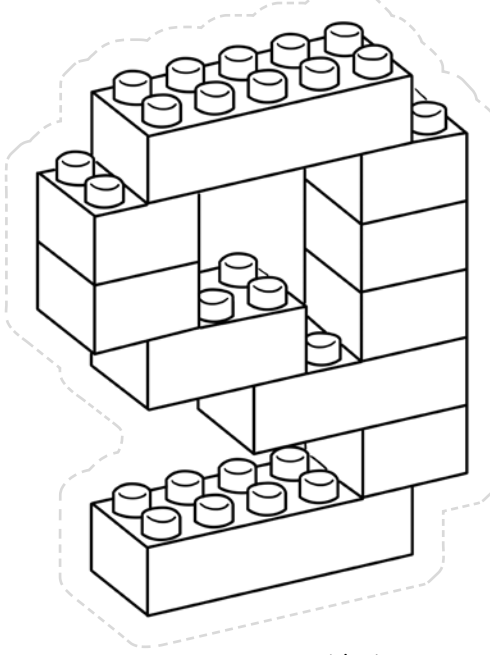

Lego blocks



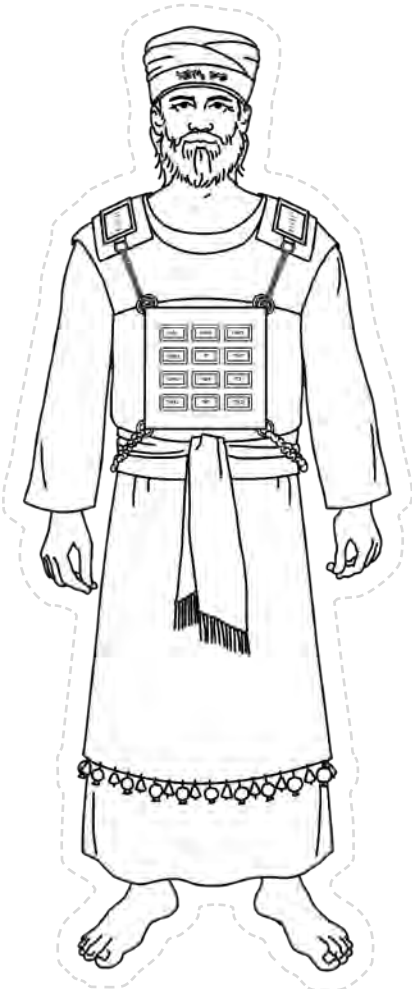

Aharon in priestly garments



Mosheh telling people to stop scene

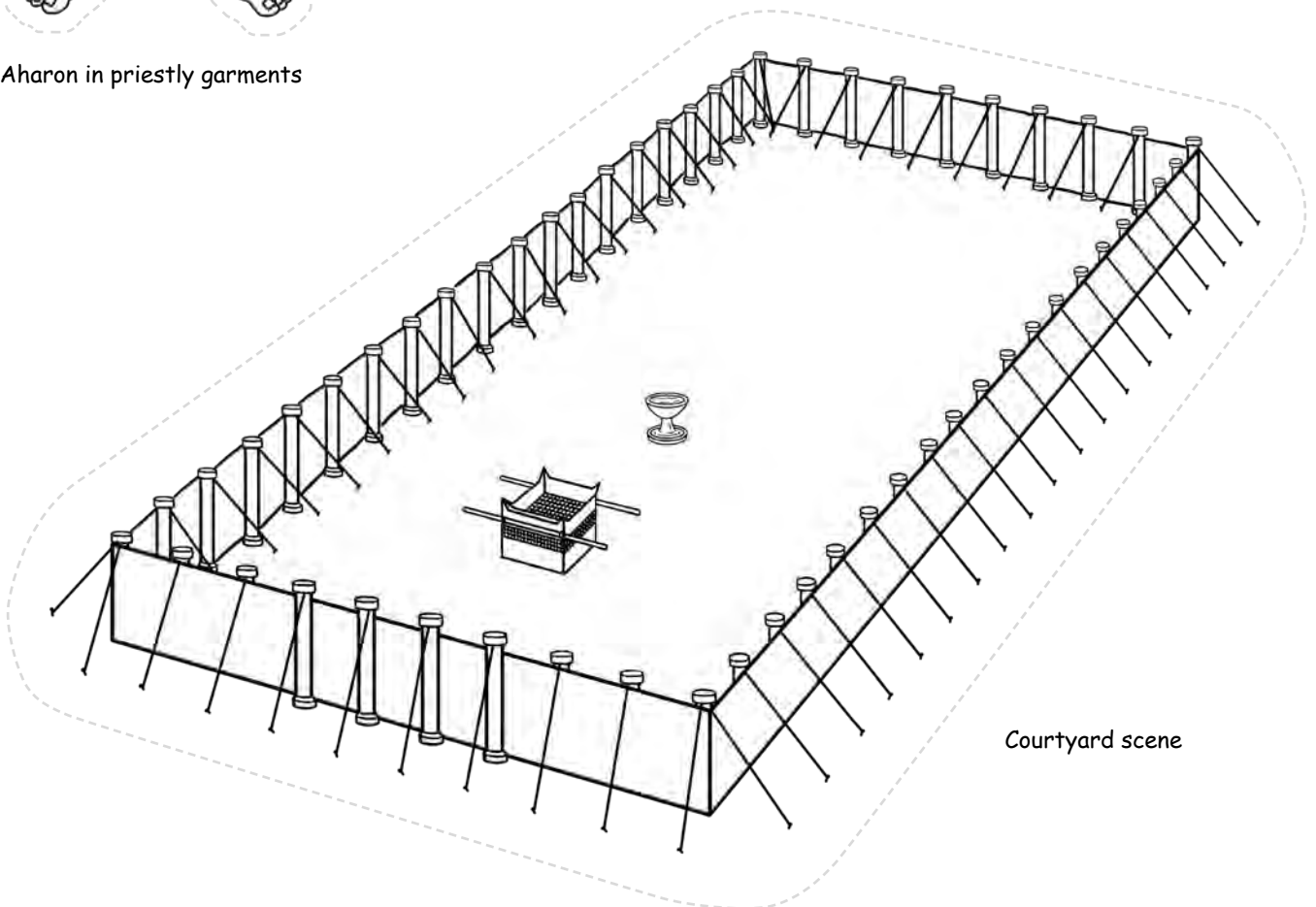

Courtyard scene

# Counting What You Gained

This next section is intended to be reinforcement of the lessons learned during this parsha. Choose the activities that best fit your child.

## STORING UP TREASURE IN MY HEART

The Katan Aleph memory verse for this Torah portion is Exodus 39:43. If they have not already done so, begin to help them to memorize the verse. Be creative and try acting it out, or putting it to music.

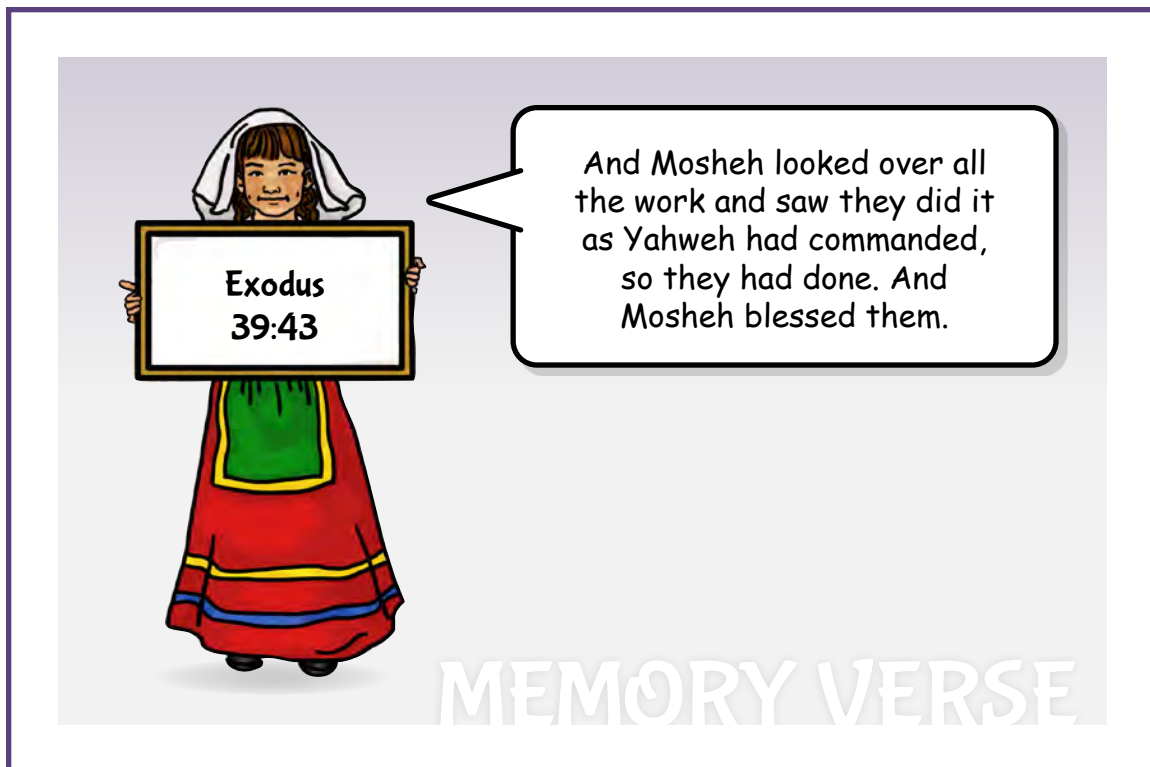



# SEEKING TREASURE

Circle the correct choices.

1. What 2 men were called by name to make the Dwelling Place? (35:30, 34; 36:2)



Betsal'el



Oholiab



Aharon



Mosheh

2. What did Mosheh have to tell the people to do when they had more than enough contributions? (36:6)



3. What does the Scriptures say Betsal'el made? (37:1)



4. What type of work did Oholiab specialize in? (38:23)



5. What metal was used to make the altar, the sockets, pegs, and the bases for the courtyard? (38:29-31)



bronze



gold



silver

# WORD SEARCH

Search for the hidden words from this week's parsha.

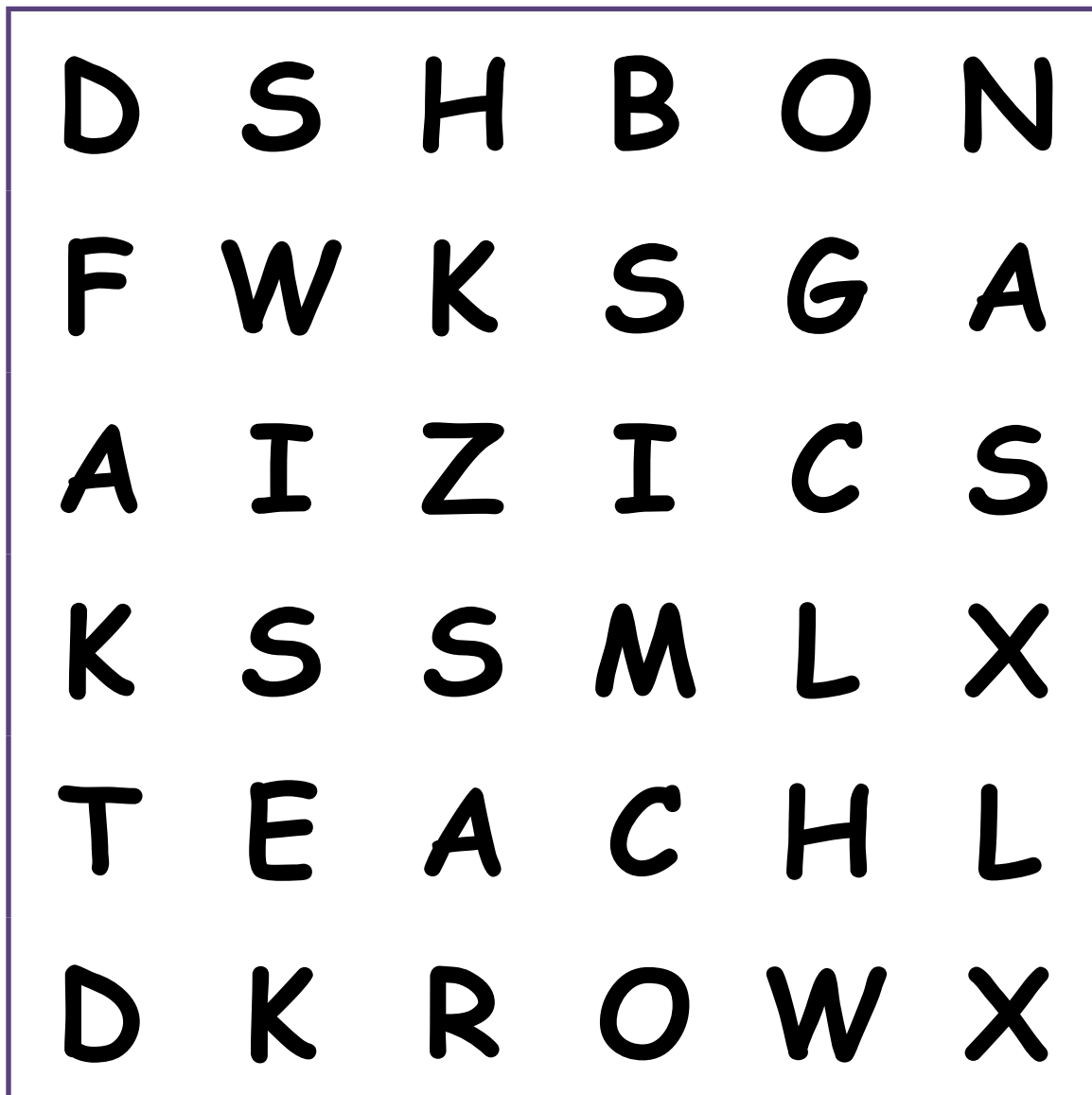

WISE  
DESIGN  
WORK  
TEACH  
SKILL



# MAZE

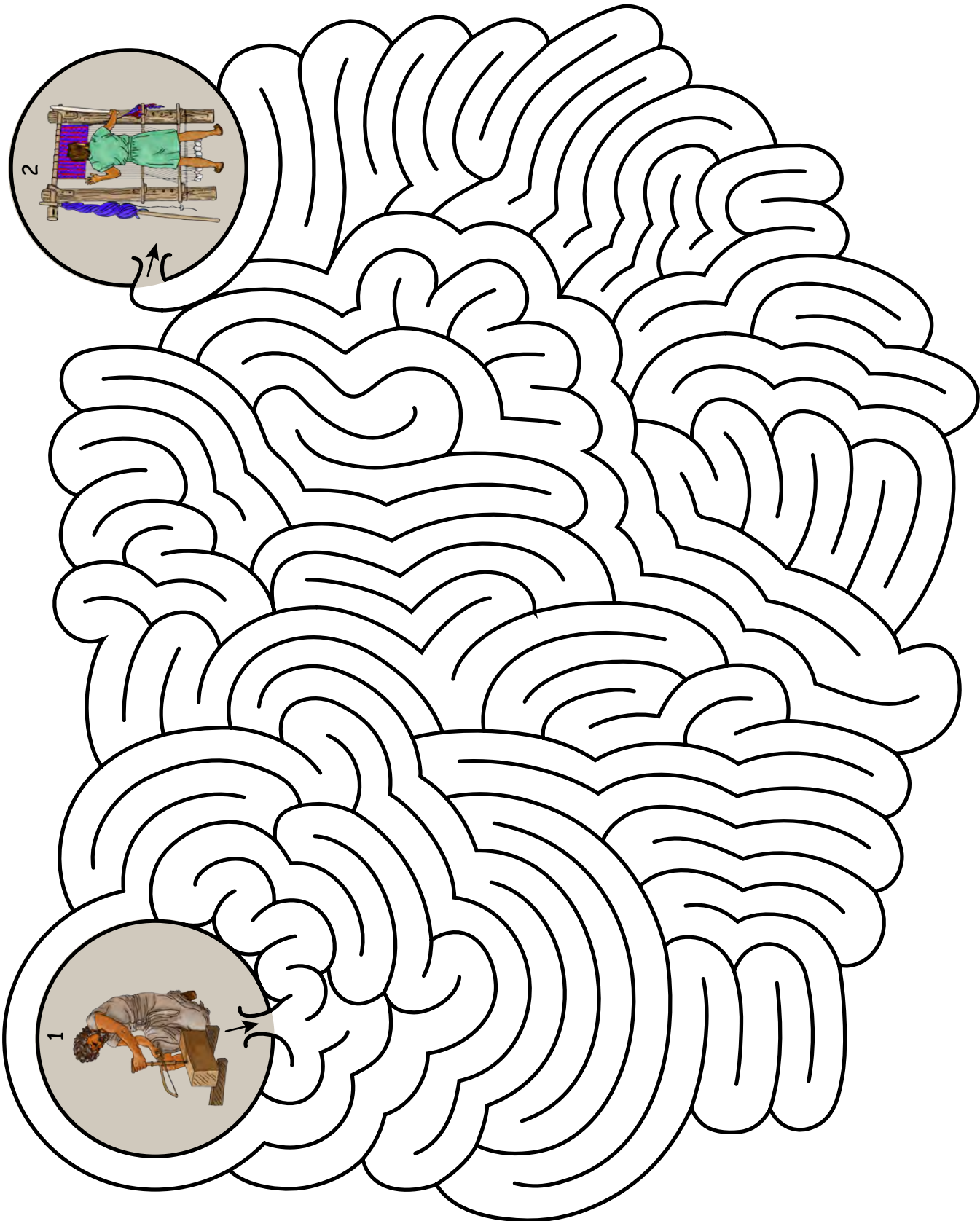

# Precious Possessions

## CRAFT

### Materials:

- Tin can with a lid (cleaned & any labels peeled off)
- Fabric or felt pieces - red, blue, purple
- Felt - white
- Felt - peel & stick (red for ram skin & color of choice - to cover can & lid)
- Gauze or linen material
- Twine
- Pleather or vinyl - brown or black (for leather covering)
- Sequins - gold, silver, bronze
- Gems or stones (12 various colors for breastplate & 2 black for shoham stones & also to decorate can)
- Craft stick or tongue depressor - wide
- Air dry clay
- Potpourri
- Glitter glue - gold
- Ruler
- Velcro dots - 'hook' & 'loop'
- Double-sided tape
- Glue
- Ribbon - about 3/4" wide
- Scissors

#### Parent/Teacher Preparation:

- This craft is intended to provide a visual representation of the contributions Yahweh asked from the Yisra'elites. Instructions will be given for each contribution.

You may want to skip to the section on how to make the air dry clay bowl a day ahead of time in order to add the 'oil' to the bowl the day you do the rest of this craft.

## Instructions for the Craft:

### Decorating the Can

- Using a peel and stick felt sheet, wrap around the can. (P1)
- Trace the lid onto the felt and cut out.
- Adhere to the lid. (P2)
- Decorate the can by gluing items of choice such as gems, sequins, stones, etc... (P3)
- Set can aside.

## Tzedakah Box

Exodus 25:1-7

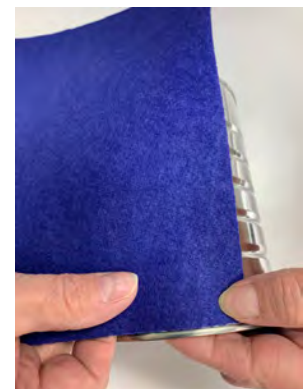

P1



P2



P3

## Instructions for the Craft Cont'd:

### *Gold, Silver and Bronze (Exodus 25:3)*

- Cut a piece of white felt 1" x 1 1/2". (P4)
- Run glue on the felt.
- Add gold, silver and bronze sequins to the glue. (P5)
- Set the finished piece aside to dry. (P6)

### *Blue, Purple and Scarlet Material (Exodus 25:4)*

- Cut the blue, purple, and red fabric or felt to 2" x 3." (P7)
- Apply double-sided tape to one end of each piece and adhere the ends to each other. (P8)
- Apply double-sided tape to the end of the blue and purple piece. (P9)
- Connect the 3 colored pieces to each other with the red on the bottom, the purple in the middle, and the blue on top. (P10)
- Set the finished piece aside. (P11)

### *Fine Linen (Exodus 25:4)*

- Cut a piece of gauze or fabric 2" x 3".
- Fold the gauze or fabric in half.
- Apply double-sided tape to one end and adhere the ends to each other.
- Set the finished piece aside. (P12)



P4



P5

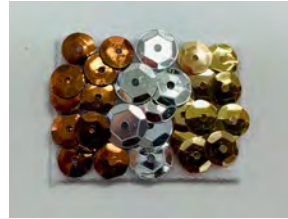

P6



P7



P8



P9



P10



P11



P12

## Instructions for the Craft Cont'd:

### *Goats' Hair (Exodus 25:4)*

- Cut a piece of twine about 1".
- Unravel the strands in the twine. (P13)
- Roll the strands into a ball. (P14)
- Cut a piece of white felt 1" x 2 1/2".
- Apply a dot of glue to the felt and place the ball of twine on the glue. (P15)
- Set the finished piece aside. (P16)



P13



P14



P15



P16

### *Ram Skins Dyed Red (Exodus 25:5)*

- Take red adhesive felt and cut into a 2" x 3" piece.
- Fold the piece in half adhering the 2 halves to each other.
- Set the finished piece aside. (P17)



P17



P18

### *Fine Leather (Exodus 25:5)*

- Take a pleather piece and cut into a 1" x 1 1/2" piece.
- Set the finished piece aside. (P18)

### *Acacia Wood (Exodus 25:5)*

- Cut a wide craft stick or tongue depressor about 1" x 1 1/2".
- Set the finished piece aside. (P19)



P19

## Instructions for the Craft Cont'd:

### *Olive Oil for the Lampstand (Exodus 25:6)*

- If not already done, using air dry clay, make a small bowl by placing a small piece over a knuckle on your hand. (P20)
- Allow the clay to harden. (P21)
- Once hard, apply gold glitter glue to the bottom of the inside of the bowl. (P22)
- Set finished piece aside. (P22)



P20



P21

### *Spices for the Anointing Oil and Sweet Incense (Exodus 25:6)*

- Cut a piece of peel and stick felt about 1" x 1 1/2". (P23)
- Take some crushed poutpourri and adhere to the sticky side. (P24)
- Set the finished piece aside. (P24)



P22



P23

### *Shoham Stones (Exodus 25:7)*

- Cut a piece of white felt about 1" x 1 1/2".
- Apply 2 dots of glue to the felt and place 2 black gems on the glue. (P25)
- Set the finished piece aside. (P26)



P24

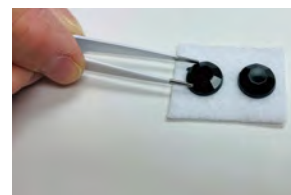

P25

### *Stones to be set in the Breastplate (Exodus 25:7)*

- Cut a piece of white felt about 2" x 3".
- Choose 12 stones or gems and glue to the felt in 4 rows of 3 stones. (P27)
- Set the finished piece aside. (P27)



P26

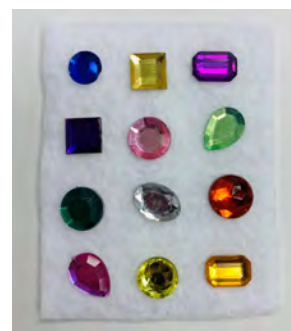

P27

# Instructions for the Craft Cont'd:

## Attaching the Contributions

- Place your finished pieces in the order of the verses from Exodus 25:3-7. (P28)
- Flip each piece and attach a *Velcro* dot 'hook side' to each one. (P29a, P29b)
- Cut a piece of ribbon about 30-36" long and 3/4" wide, making sure the ribbon is wide enough to cover the *Velcro* dots.
- Connect a *Velcro* dot 'loop side' to the 'hook side' on each contribution piece making sure that the sticky side is visible to be laid on the ribbon. (P30)
- Lay each piece on the ribbon leaving about 1/2" between each item. (P31a, P31b, P31c, P31d, P31e, P31f, P31g, P31h, P31i, P31j, P31k)
- Your contributions are now finished. (P32)



P28

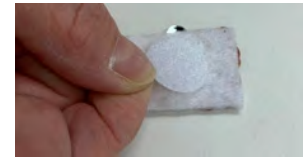

P29a

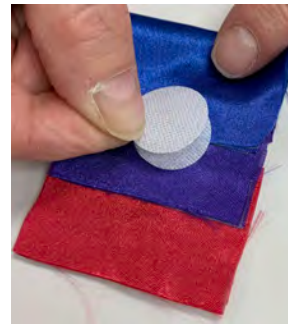

P30

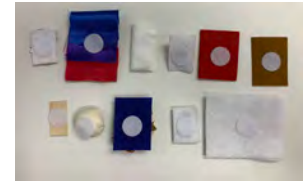

P29b

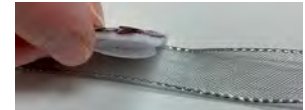

P31a



P31b



P31c



P31d



P31e



P31f



P31g



P31h



P31i



P31j



P31k



P32

## Instructions for the Craft Cont'd:

### Finishing the Craft

- Attach a *Velcro* dot 'loop side' to the inside of the lid. (P33)
- Attach a *Velcro* dot 'hook side' to the end of the ribbon with the gold, silver, and bronze sequins. (P34a, P34b)
- Place the contributions ribbon inside the can. (P35)
- Place the lid onto the can. (P36)



P33



P34a

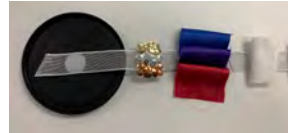

P34b



P35

*You now have a visual representation of the contributions that were bought from everyone whose hearts were moved to do so for the Dwelling Place.*



P36

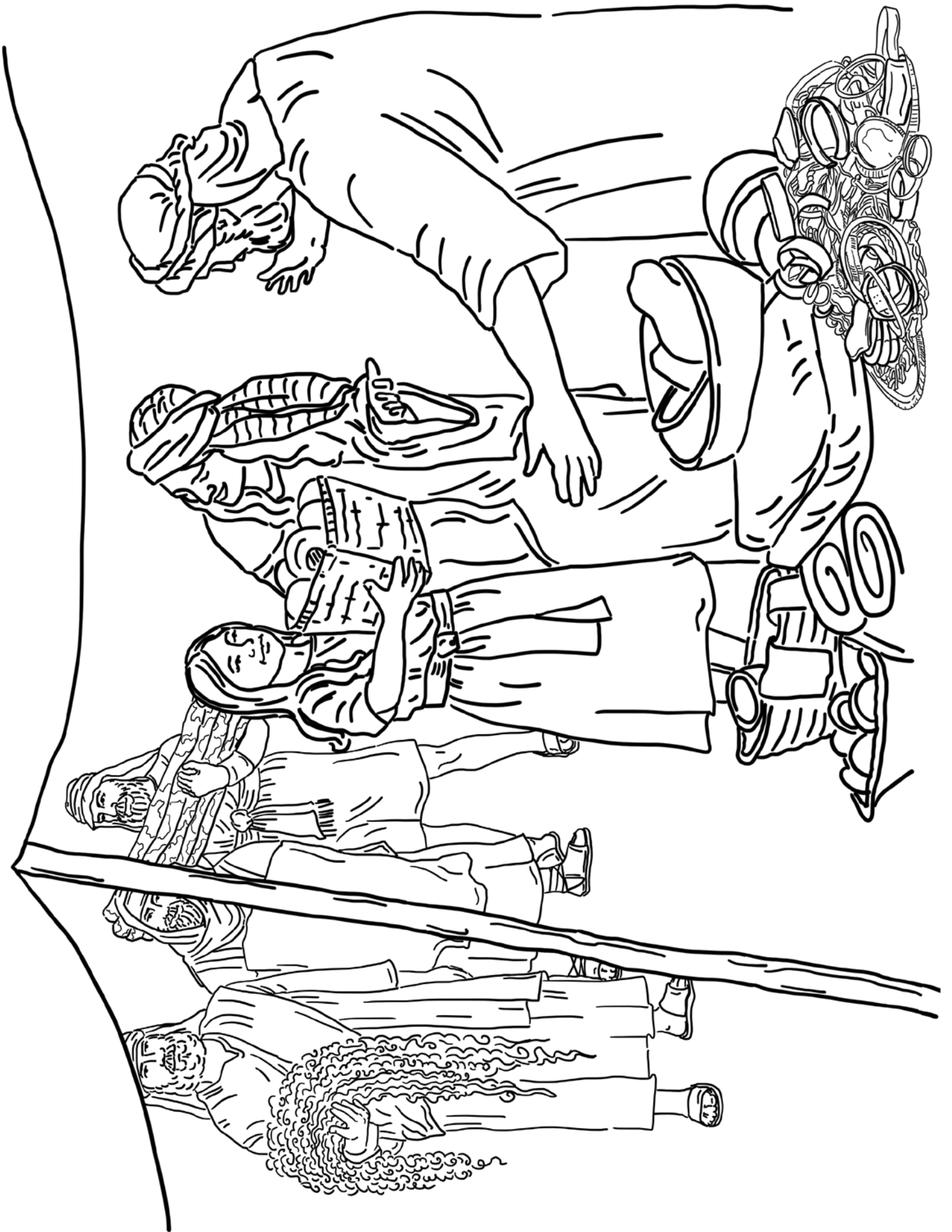

---

# Sweetness of Torah

---

## SWEET SOUNDS OF TORAH

(Sing Praises to His Name)

Here is the link for this song:

[https://www.podomatic.com/podcasts/steveberkson/episodes/2024-02-29T22\\_00\\_00-08\\_00](https://www.podomatic.com/podcasts/steveberkson/episodes/2024-02-29T22_00_00-08_00)

### If Your Heart Is Lifted Up

If your heart is lifted up  
If your heart is lifted up  
Bring an offering for the Dwelling Place  
(Repeat)

All the wise-hearted, men and women gave  
Until Mosheh said, "We have more than enough"

If your heart is lifted up  
If your heart is lifted up  
Bring an offering for the Dwelling Place  
(Repeat)



# SWEET TASTE OF TORAH

This snack relates to this week's parsha. Please take these as suggestions and make necessary changes based on your individual dietary needs.

## Contributions

Exodus 25:3-4; 35:5-6



## Ingredients:

- Pretzel rods (represents acacia wood)
- Gold coins (represents gold)
- Gold wrapped chocolate nuggets (represents gold)
- Fruit Strips (represents coverings)
- *Fruit Gushers* (represents gems)
- *Fruit by the Foot* (represents blue, purple and red covering)
- Jelly beans (represents gems)

## Instructions:

Choose ingredients of choice to represent the colors and materials of the Tabernacle and the plentiful contributions that the children of Yisra'el brought to help make the Dwelling Place.

# Next Week's Treasure Hunt

## Next Week's Torah Portion

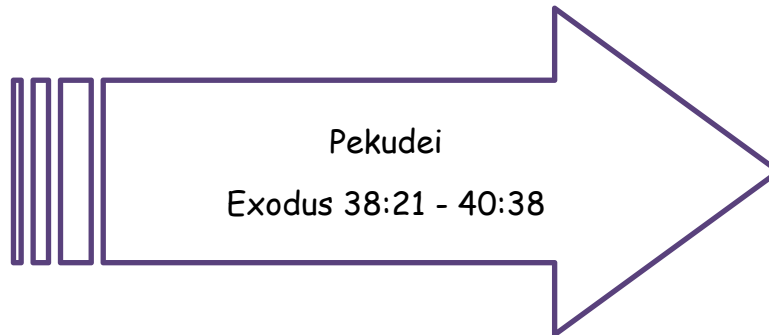

## Suggested Reading Schedule

Monday:	Ex. 38:21-31	Listing of metals and amounts used in construction of the Dwelling Place
Tuesday:	Ex. 39:1-31	Making the set-apart garments
Wednesday:	Ex. 39:32-43	Setting up the Dwelling Place
Thursday:	Ex. 40:1-15	Raising up the Dwelling Place
Friday:	Ex. 40:16-38	Mosheh does all that Yahweh told him to do; The esteem of Yahweh upon the Dwelling Place; cloud and fire