

Parsha Pearls

Pekudei

"Amounts or Accounts"

Exodus 38:21 - 40:38
Katan Aleph



In This Edition:

23.1 - Raising Up the Dwelling Place
Exodus 40



Table of Contents

Parsha Pearls is a comprehensive resource that allows for complete customization by the parent. We understand that if you were to strive to accomplish all aspects of each lesson in one day it would be unrealistic and also overload for the child. It is our intention that this be used 'a la carte' so that it suits your specific needs. Our site caters to printing only the pieces you choose.

This page will provide quick links to get to the portion of the document for which you are looking. When you hover over the title a finger will appear. Click on it and you will be taken directly to that page.

If you are new to Parsha Pearls, we have created an [Introduction](#) document outlining how to use our lessons, as well as a [Scriptural Inspiration](#) document, which explains our titles and the Scriptural inspiration for them. We pray that Parsha Pearls blesses your home and that your children will grow to love the Word and to never depart from keeping Torah. As always, feel free to email us at parshapearls@mtoi.org if you have any questions.

Gem Seeking (The Main Lesson)	3
➤ Little Gems Story (Story for Younger Children)	3
➤ Little Gems Story Characters	6
Counting What You Gained (Worksheets)	16
➤ Storing Up Treasure in My Heart (Memory Verse)	16
➤ Seeking Treasure (Questions from the Parsha)	18
➤ Word Search	19
➤ Maze	20
Precious Possessions (Arts & Crafts)	21
➤ Craft	21
➤ Coloring Page	23
Sweetness of Torah	24
➤ Sweet Sounds of Torah (Song Corresponding to the Parsha)	24
➤ Sweet Taste of Torah (Snack Corresponding to the Parsha)	25
Next Week's Treasure Hunt (Looking Ahead to Next Week's Parsha)	26



Gem Seeking

LITTLE GEMS STORY

Parent/Teacher Preparation:

Please see the [Instructions for the Little Gems Story](#) on the YMTOI website. This will help you to understand how to prepare for the story.

Raising Up the Dwelling Place

Shalom, children! Well, it's hard to believe a whole year has gone by since the children of Yisra'el said goodbye to Mitsrayim. It's now the beginning of their second year of freedom - Month #1, Day #1. For the past year, everyone has been working like busy bees, making all the parts of Yahweh's Dwelling Place, exactly as He told Mosheh to make it. **(Place Mosheh on board.)** How will it all come together? Have you ever had a project to do, and you just didn't know where to start? Well, Yahweh who is not only a master architect, but a master builder thought of that. Let's watch as He tells Mosheh how to raise up His Dwelling Place, one step at a time. It will be perfect.

Now, Yahweh's house had different areas in it, just like your house. You have a kitchen for eating and cooking, and a living room with comfy places to sit, and maybe even a yard for throwing frisbees and a lot of other fun things. The Dwelling Place of Yahweh had three areas, where He wanted special things done that would honor Him as Elohim.

The first area was the Most Set-apart Place. Only one piece of furniture would go in there; can you remember what it was? **(Let children answer.)** Yes, the ark of the Witness, with its solid gold cover that had the kerubim on it. **(Place ark of the Witness on board and point to kerubim.)** But first, Mosheh had to get the ark all ready. Inside the golden box he placed the Witness - the tablets that Yahweh wrote on. **(Place tablets on board.)** Then he slid its carrying poles through the rings, and topped it off with the golden lid of atonement. **(Point to items.)** It was like a throne for the Mighty One of Yisra'el. So Mosheh was told to set up the ark first, and to hide it behind the purple, blue and scarlet inner veil that had the kerubim on it. **(Place inner veil in front of the ark on board.)** On the other side of the veil was the second area, the Set-apart Place. Mosheh had to set up three pieces of furniture there. In the center, just on the other side of the veil hiding the ark, he was to set the golden altar of incense and its utensils. **(Place altar of incense and utensils in center of veil on board.)** On the north side, he was to bring in the table and arrange its showbread, dishes and utensils. **(Place table and utensils to the right of the altar of incense on board.)**

Then he was to set up the golden lampstand on the south side and to light its seven lamps and its utensils. **(Place lampstand, utensils and olive oil to the left of the altar of incense on board.)** In front of these furniture pieces was the purple, blue and scarlet outer veil. **(Place outer veil in front of furniture pieces on board.)**



The third area would be the courtyard all around the outside the Tent of Meeting. **(Place empty courtyard on board.)** That's where Mosheh was told to set the bronze wash basin, right between the Tent and the altar where the offerings were made. And what was Mosheh supposed to put in the basin? Yup, water. You are all so smart today! We all know it's pretty hard to wash up without water! **(Place wash basin on board.)** Our last furniture piece along with its utensils was the bronze altar where the sacrifices were to be done. **(Place bronze altar and utensils on board.)**

Next, Yahweh told Mosheh to anoint everything with Yahweh's wonderful-smelling anointing oil, to mark each piece as set apart only for the service of Yahweh. **(Place anointing oil on board. Point to all items as you read about them.)** He had to walk all around the inside of the Dwelling Place and put the oil on every piece of furniture and every utensil, and also on the Tent itself. Then he must go outside and put the anointing oil on the basin as well as the bronze altar for burnt offerings and on all its utensils. That must have been a pretty big jar of oil he was carrying around!

Finally, he was to set apart Aharon and his sons to be priests to Yahweh. Aharon the High Priest would go first. Mosheh was to wash him clean and put the beautiful high priestly garments on him. Then he must grab that jar of oil and pour a bunch of it all over Aharon's head. **(Remove Mosheh from board and place Mosheh anointing priests on board. Point to Aharon.)** It would be the same for Aharon's four sons. They were to be washed, dressed in their long shirts and turbans, and have their heads doused with the special oil, too. **(Point to Nadab, Abihu, El'azar and Ithamar on board.)** Yahweh said that the priesthood would be theirs forever. In other words, the priests of Yisra'el would always come from Aharon's family. His sons would be priests, and then his grandsons, his great-grandsons, his great-great grandsons, and on and on. Aharon and his sons must have felt very honored when they heard that.

(Remove all characters from board.)

Now, I think this Dwelling Place must have been Yahweh's most important, special, favorite building that was ever, ever made on earth. Over and over, the Scriptures talk about every detail that went into making it, and how Mosheh did it all exactly the way Yahweh said. Just hang with me for a minute while we watch Mosheh actually raise up the whole Dwelling Place, the way Yahweh showed him on the mountain. **(Place Mosheh on board.)** When it's all put together, we'll get to see something absolutely amazing. Okay, are you all listening?

Remember, it was now the second year since they came out of Mitsrayim - Month #1, Day #1 - the day Yahweh appointed for the Dwelling Place to be finished. To begin, Mosheh set up its gold-covered boards, with the bars to keep them standing straight. The columns he put where they could hold up the curtains and veils. **(Place Dwelling Place frame on board.)** The tent was spread over that, and its four coverings went over the top. **(Remove Dwelling Place frame and place Dwelling Place on board.)**

(Remove Dwelling Place and place Dwelling Place cut-out on board.)

And what was the first piece of furniture to go inside? That's right - the ark of the Witness. **(Point to ark of Witness on board.)** Since it was the most important piece, it was put in the Most Set-apart Place. He had the ark carried inside the Most Set-apart Place, and then he hung the beautiful inner veil, to separate that area from everything else. **(Point to inner veil on board.)**

On the other side of that veil, in the Set-apart Place, he set the golden altar in the center and burned sweet incense on it. **(Point to altar of incense on board.)** Mmm, what a fabulous fragrance! Then in came the lampstand on the north side. **(Point to 7-branch lampstand on board.)** What joy Mosheh must have felt as he lit its seven lamps and admired the beauty of Yahweh's home! Finally, he put the table, with the showbread arranged on it. **(Point to table of showbread on board.)** He hung the outer veil over the entryway, then went outside. **(Point to outer veil on board.)**

(Remove Dwelling Place cut-out and place Dwelling Place with courtyard on board.)

Outside of the Tent of Meeting, he placed the bronze basin on its stand and filled it with water. **(Point to bronze basin on board.)** Yahweh had commanded that every time the priests came to the Tent of Meeting, or to the altar of burnt offering, they must first wash their hands and feet with the water in the bronze basin. Beyond that, he set up the bronze altar, in line with the Tent door, and got right to work offering the burnt offering and the grain offering. **(Point to bronze altar on board.)** Now the whole area was filled with smells that pleased Yahweh!

To finish, Mosheh put up the columns and screens for the courtyard, all around the altar area and the Tent of Meeting. **(Point to columns and screens on board.)** Mosheh followed the exact pattern that Yahweh showed him. Now the work was all done, but what was missing? Why, the Presence of Yahweh! Suddenly, the people gasped and pointed. There over the Dwelling Place was a bright cloud! It billowed out until it covered the Tent of Meeting and flooded the whole Dwelling Place with Yahweh's brilliant splendor. It was so awesome that Mosheh couldn't even go in there! Later, that bright cloud became a tall pillar, stretching way up into the sky. **(Place pillar of cloud over Dwelling Place on board.)**

When it got dark, do you think they could still see it? Yeah, you bet they could, because each night it turned into a blazing column of fire. **(Remove pillar of cloud and place pillar of fire over Dwelling Place on board.)** Wow!

Maybe only the priests would ever see inside the Tent of Meeting, but the cloud of Yahweh's Presence could be seen 24/7, by every single Yisra'elite. **(Place family on board.)** Whenever the cloud lifted up from the Dwelling Place, that was Yahweh's sign for them to pack up and move on. But where? Well, they just had to follow the cloud until it stopped somewhere! Then they would have to set up the Dwelling Place all over again, and put up all their own tents around it. Imagine poking your head out of your tent each morning, and checking to see... **(Place tent scene on board.)** Well, what would you look for? The cloud, of course! Had it lifted up? Would you all be doing a big pack job and a long march, or would you be hanging out munching manna for another day? You just never knew. The Scriptures say we don't know what a day might bring. Yahweh is in control, and we must follow and obey in every detail, just as Mosheh did.

Well children, we have come to the end of our story for today. We will see you next week for another exciting Little Gems story!





Mosheh



Ark of the Witness

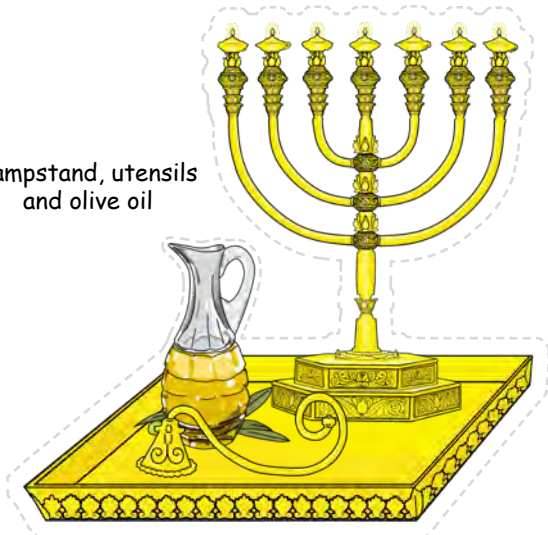

Lampstand, utensils and olive oil

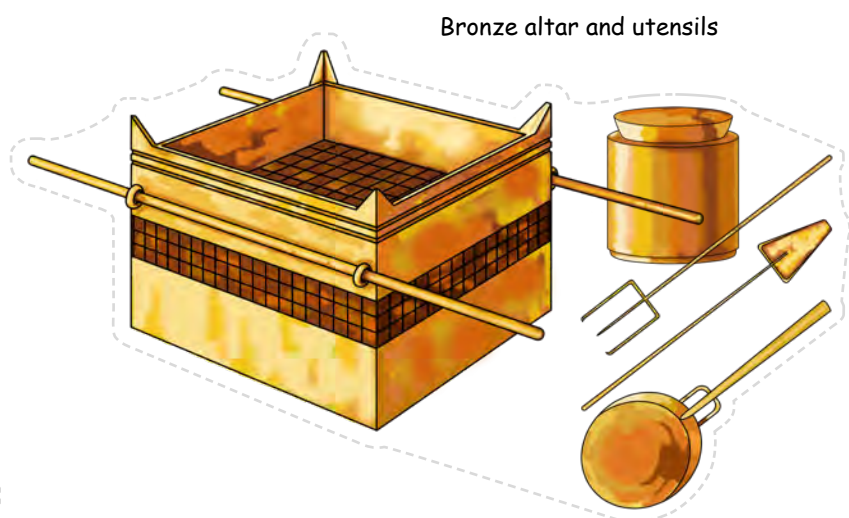

Bronze altar and utensils

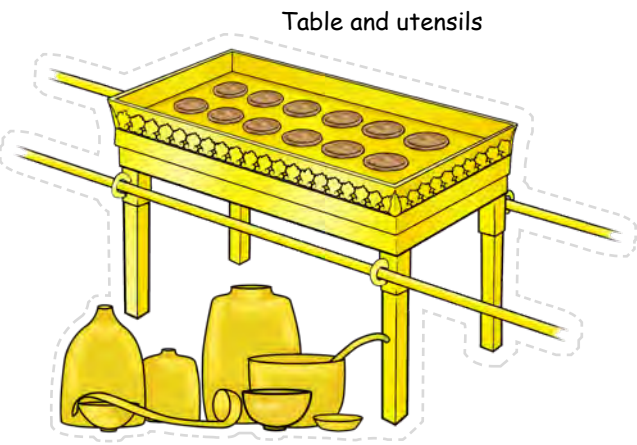
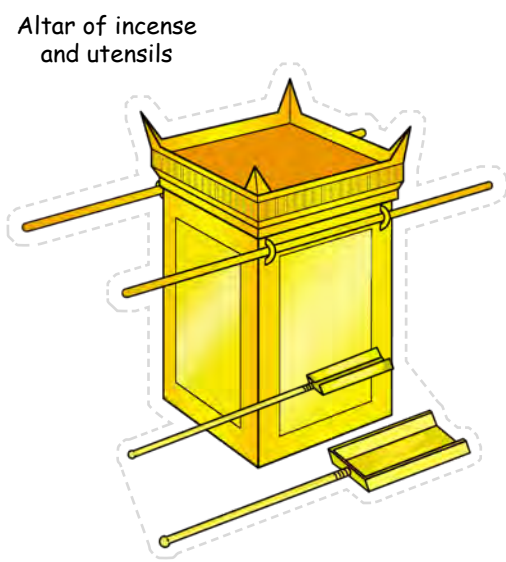

Table and utensils



Altar of incense and utensils



Anointing oil



Wash basin

Dwelling Place

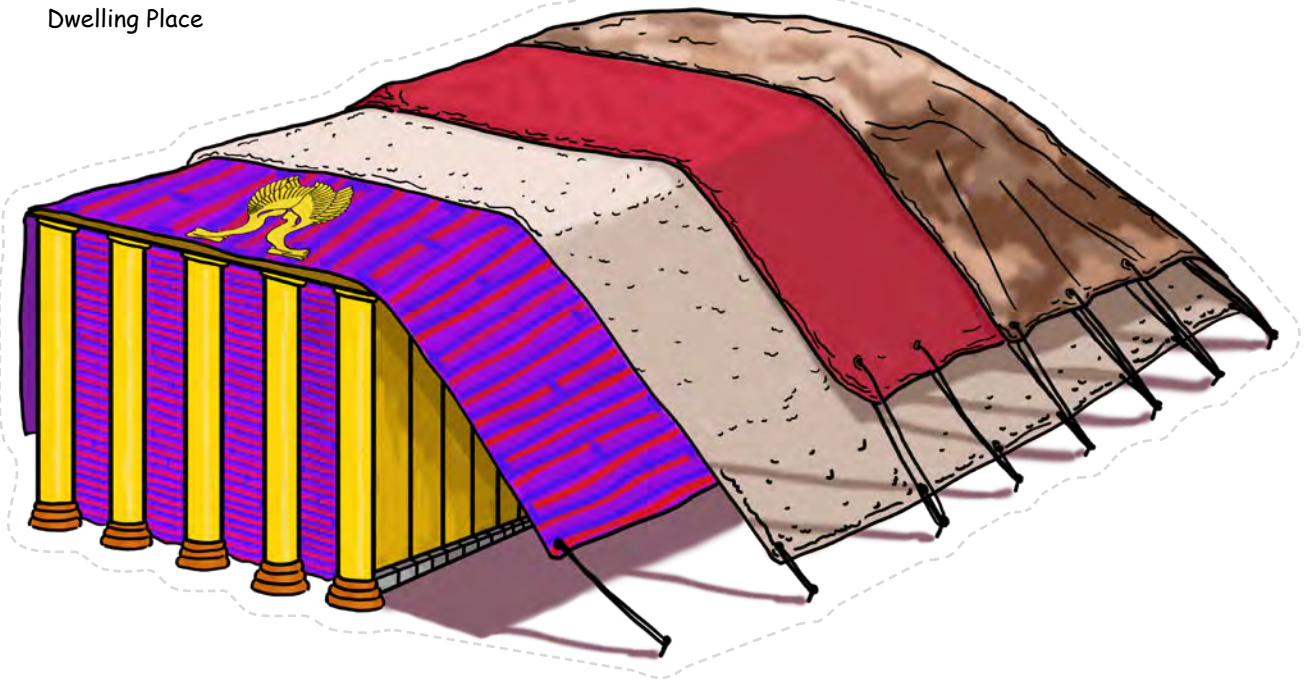

Courtyard

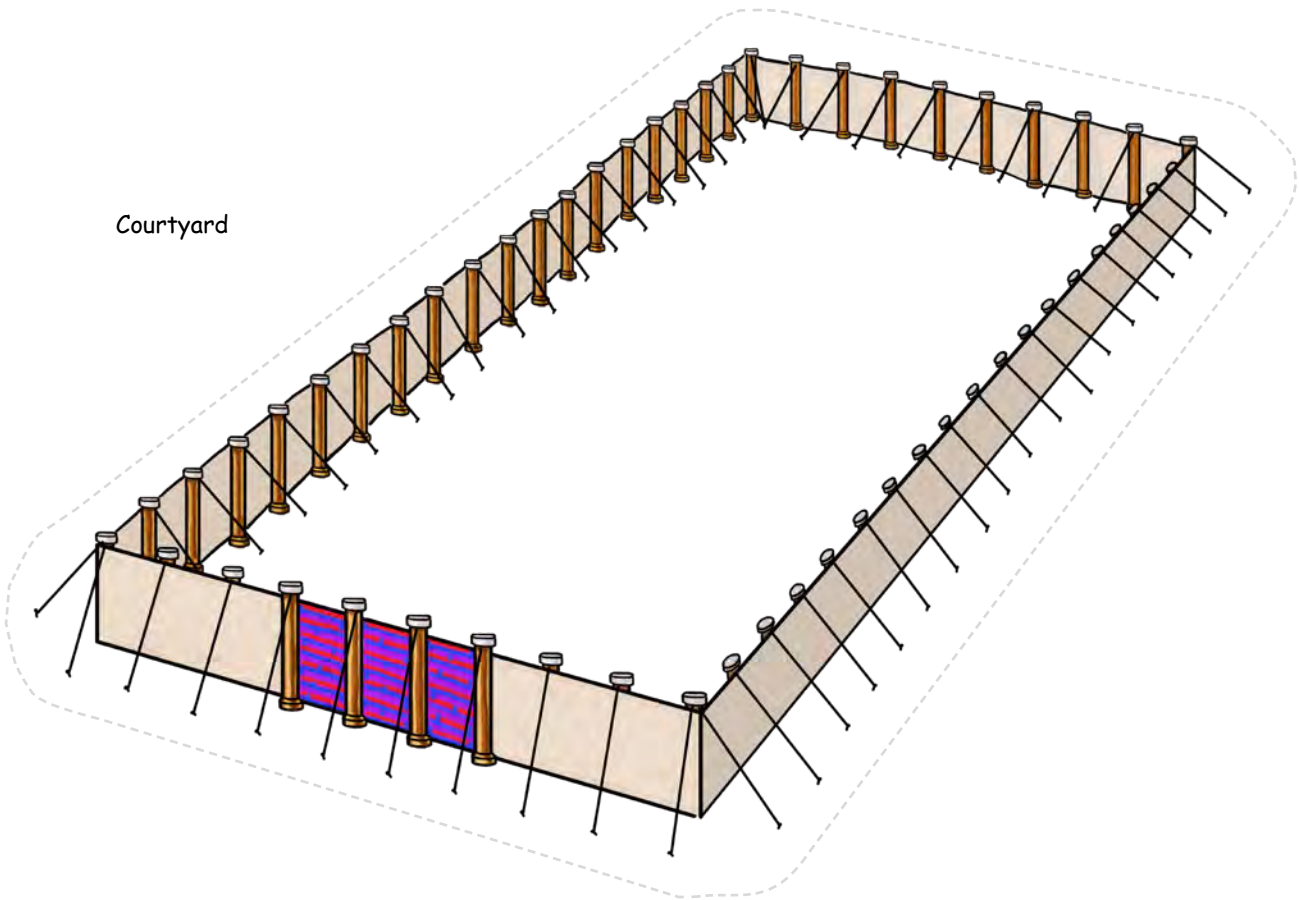

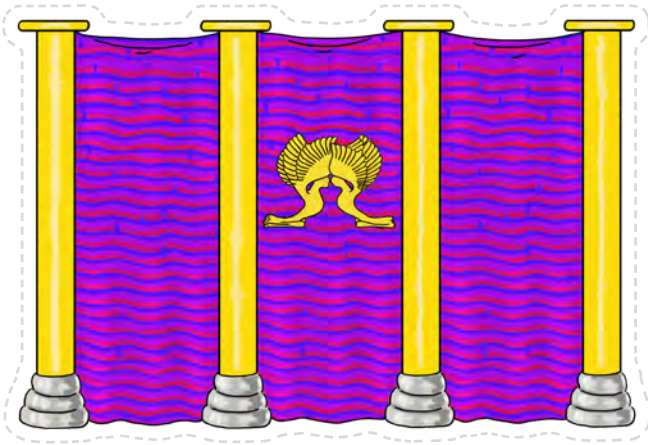

Inner veil

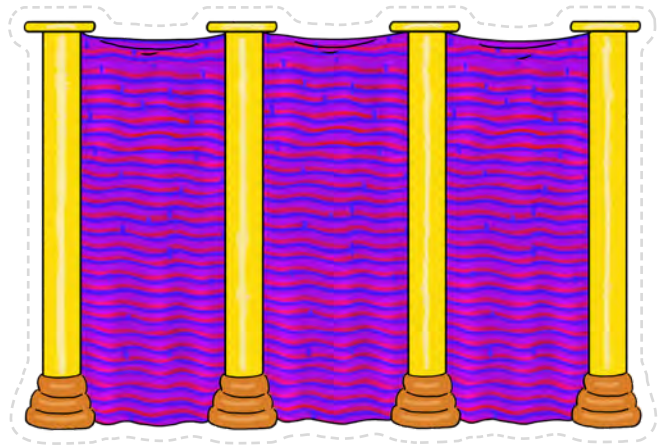

Outer veil



Family



Tablets

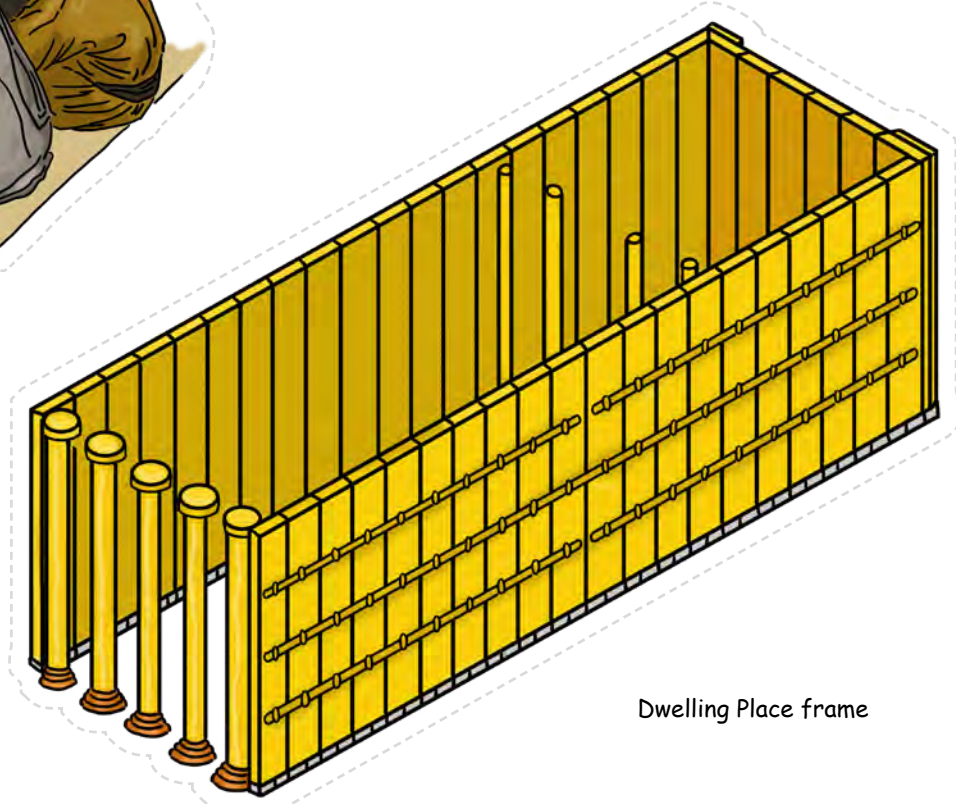

Dwelling Place frame

Dwelling Place with courtyard

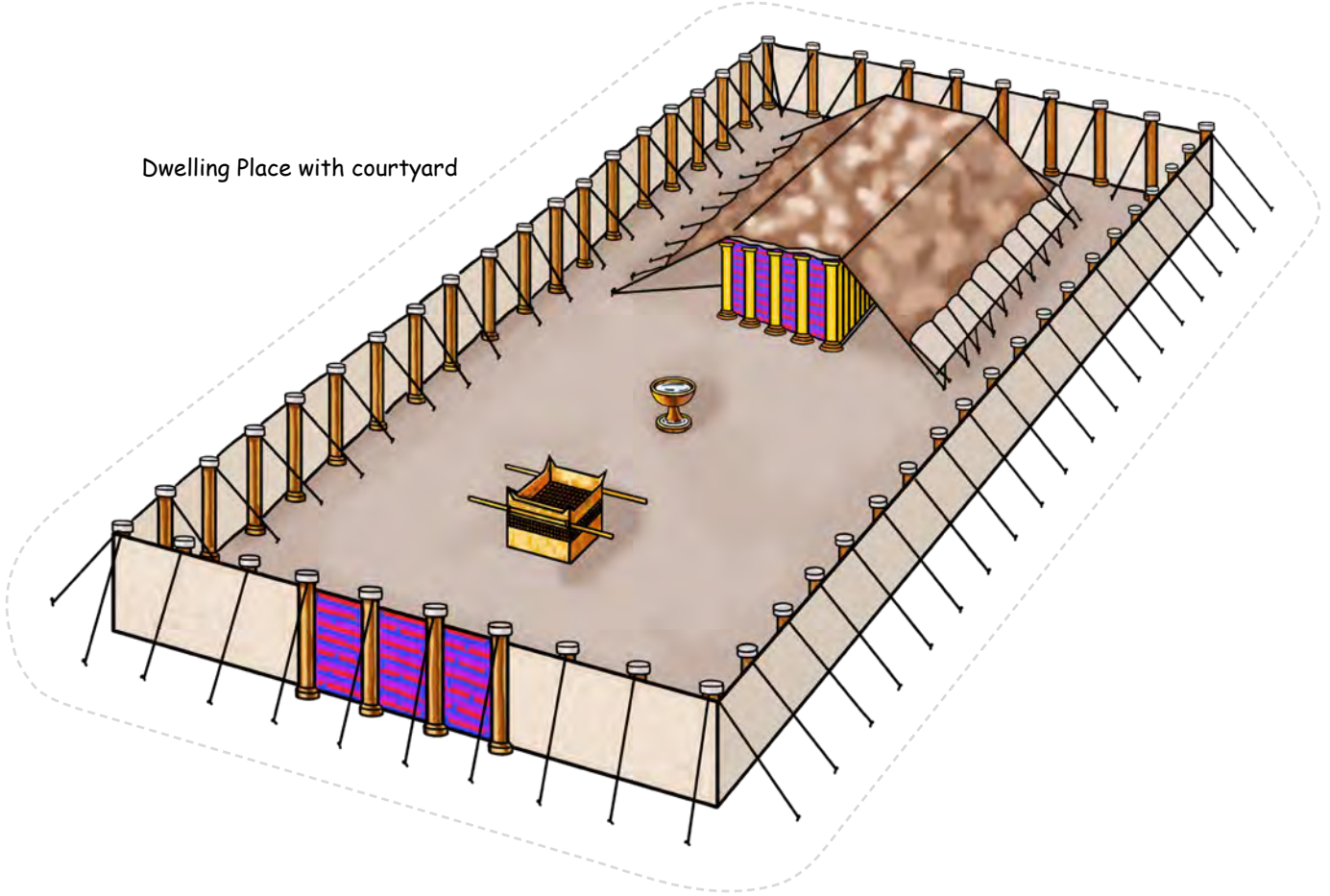

Dwelling Place cut-out

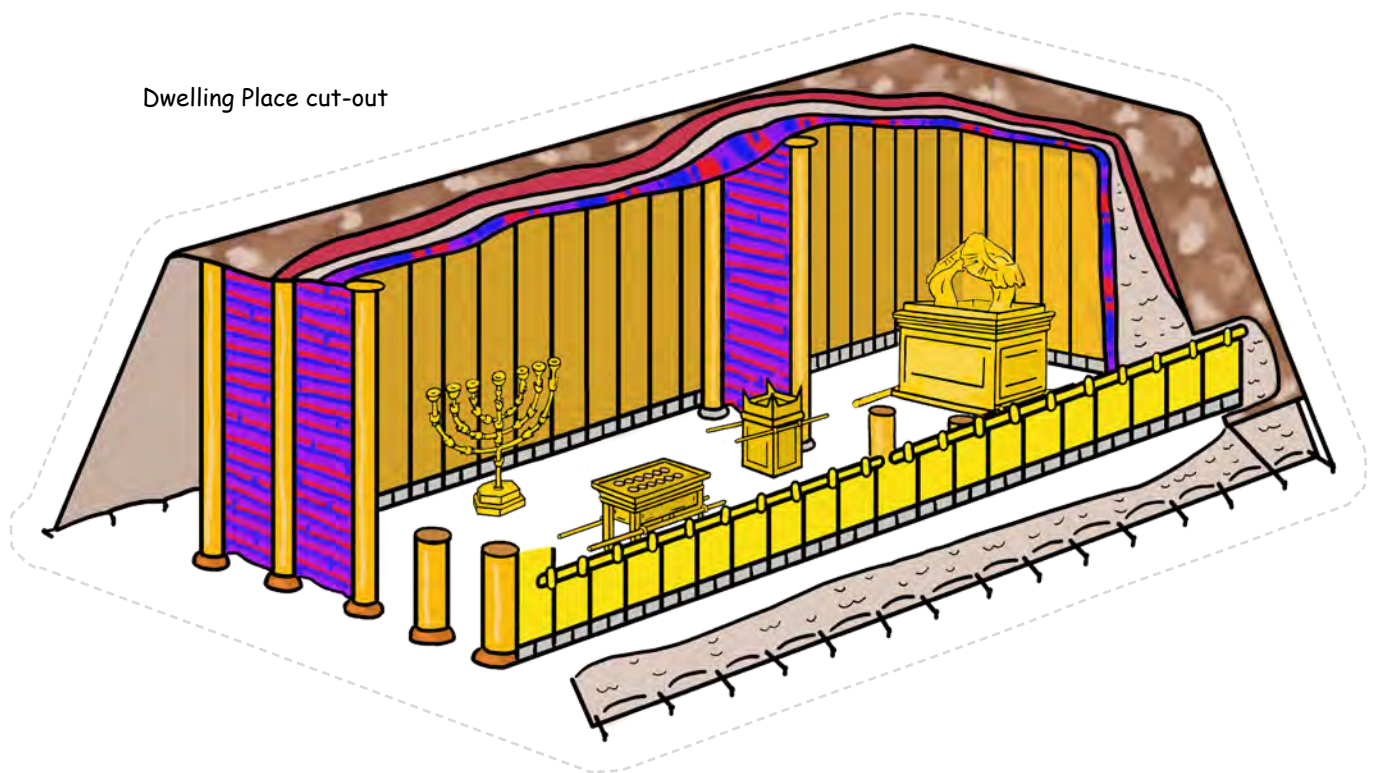



Mosheh anointing priests

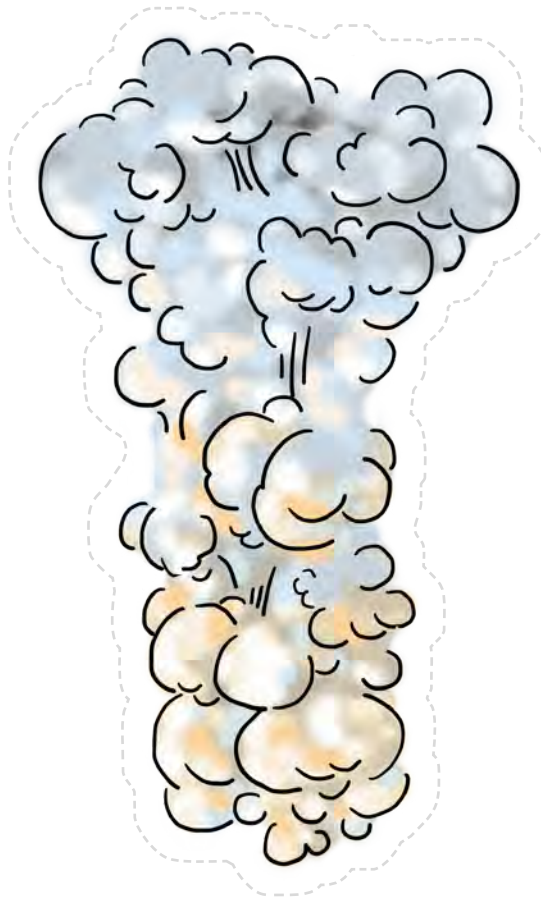

Pillar of cloud

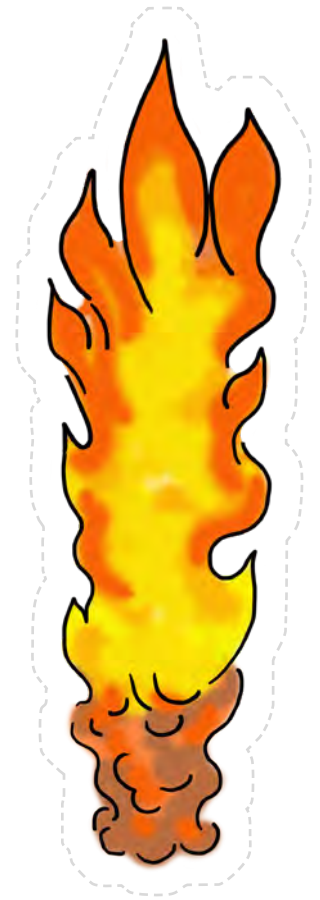

Pillar of fire

Tent scene





Mosheh

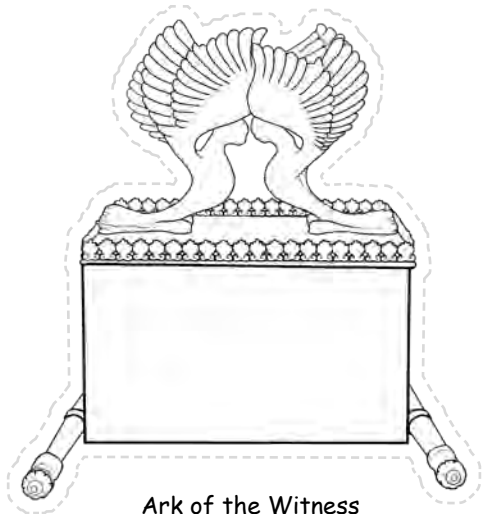

Ark of the Witness

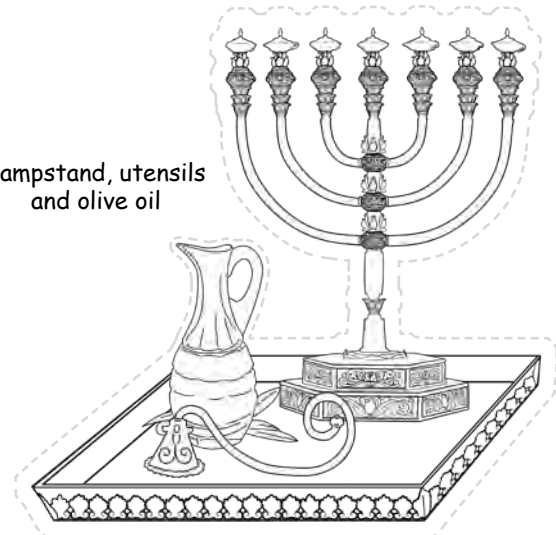

Lampstand, utensils and olive oil

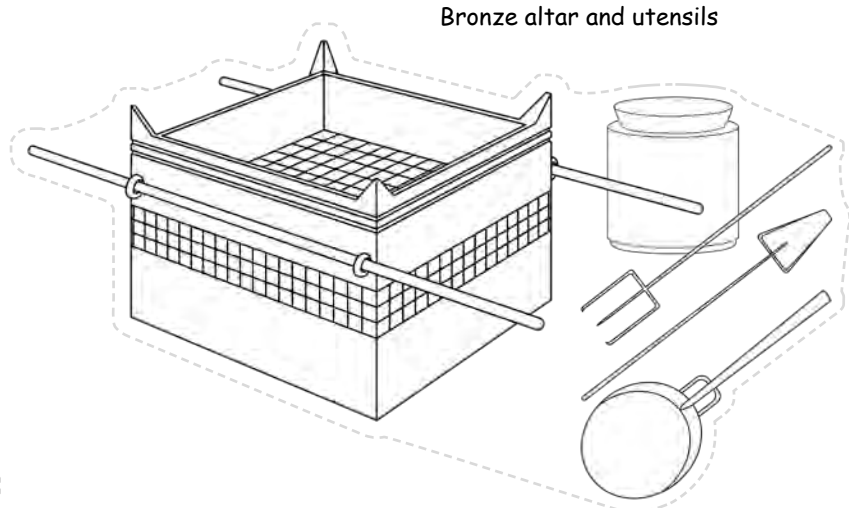

Bronze altar and utensils

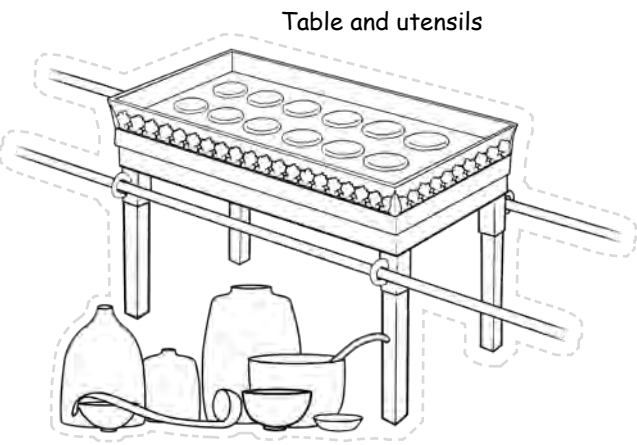
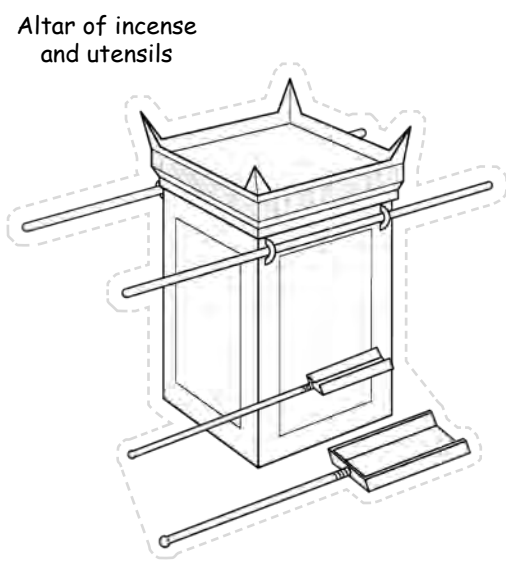

Table and utensils



Altar of incense and utensils



Anointing oil



Wash basin

Dwelling Place



Courtyard

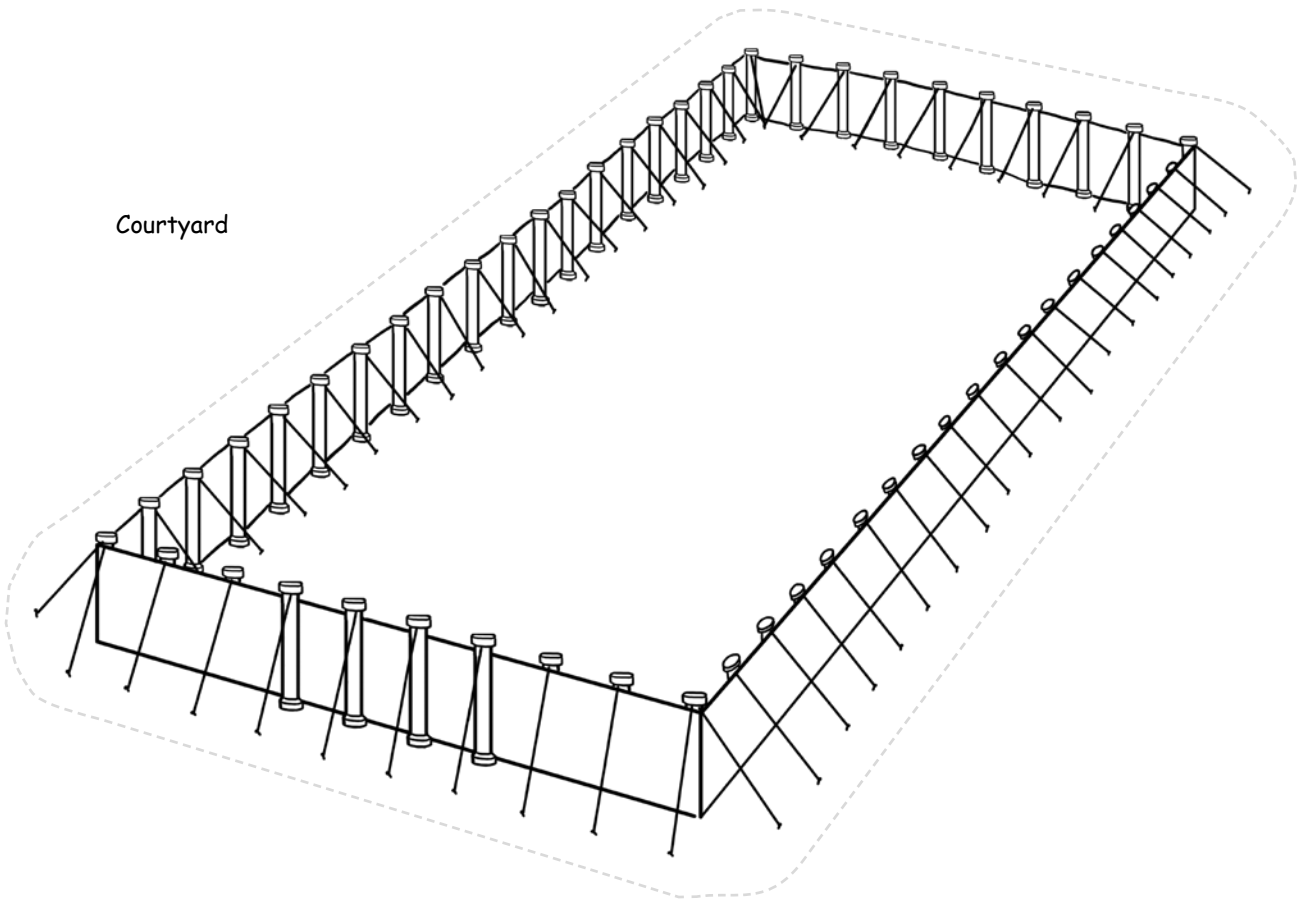

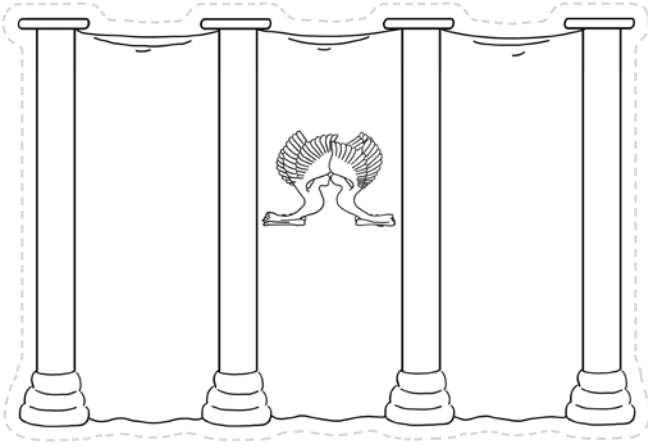

Inner veil

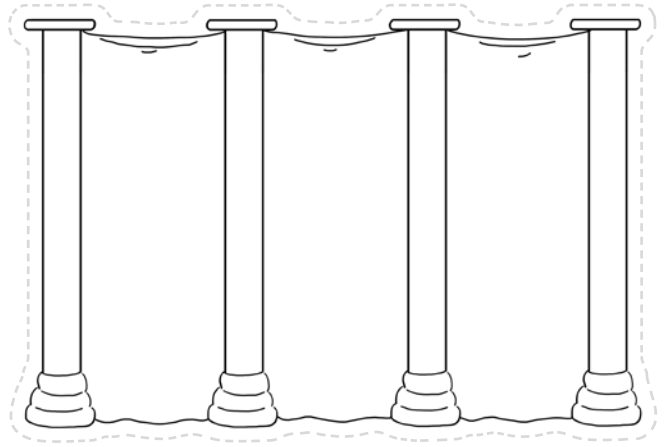

Outer veil



Family



Tablets

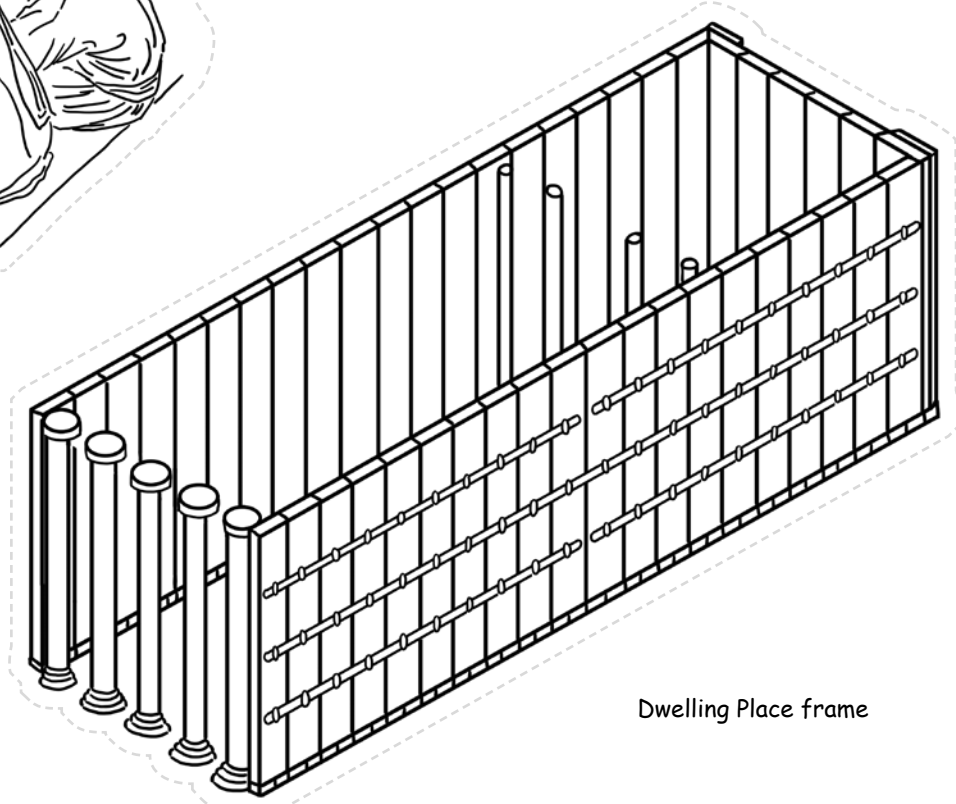

Dwelling Place frame

Dwelling Place with courtyard

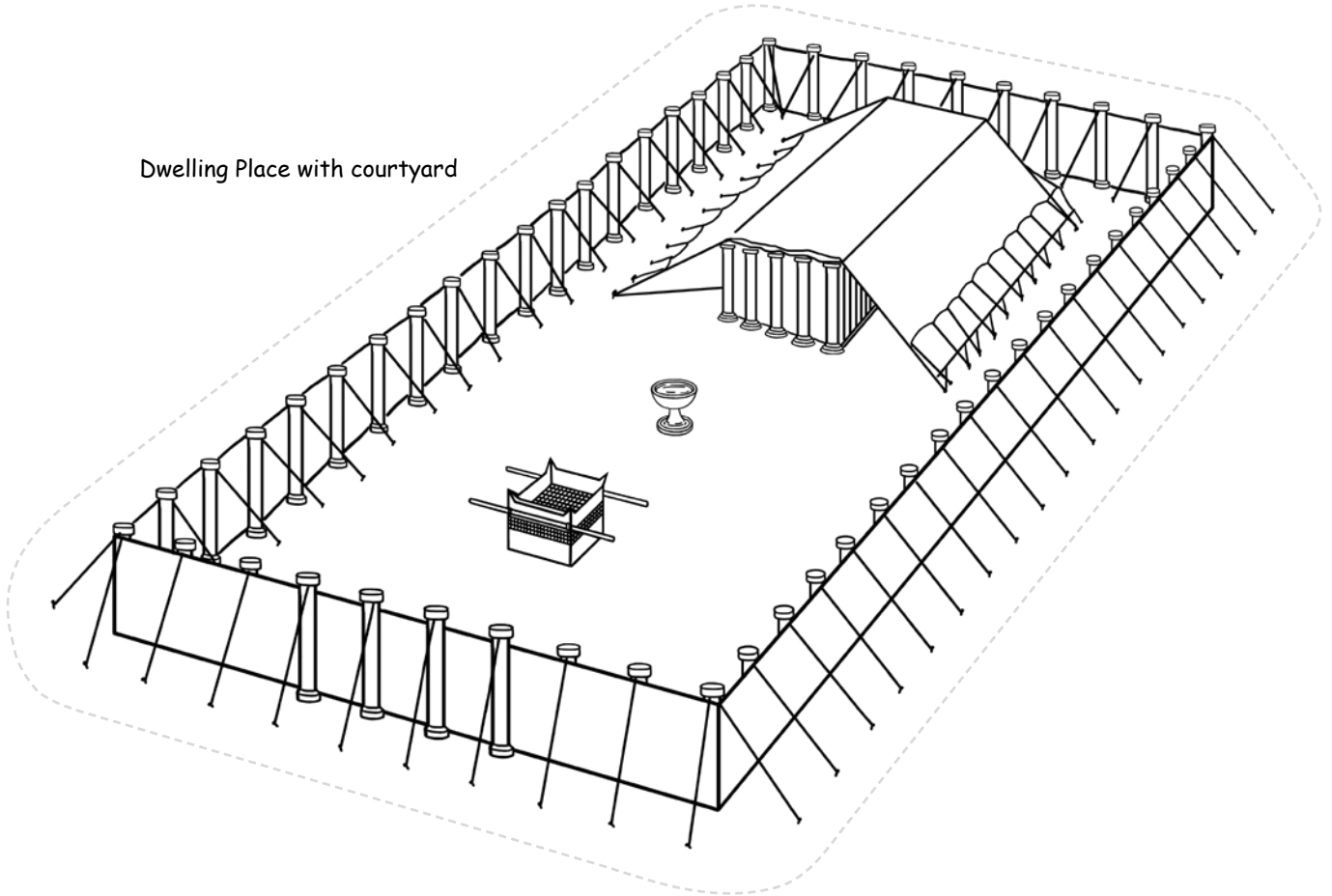

Dwelling Place cut-out

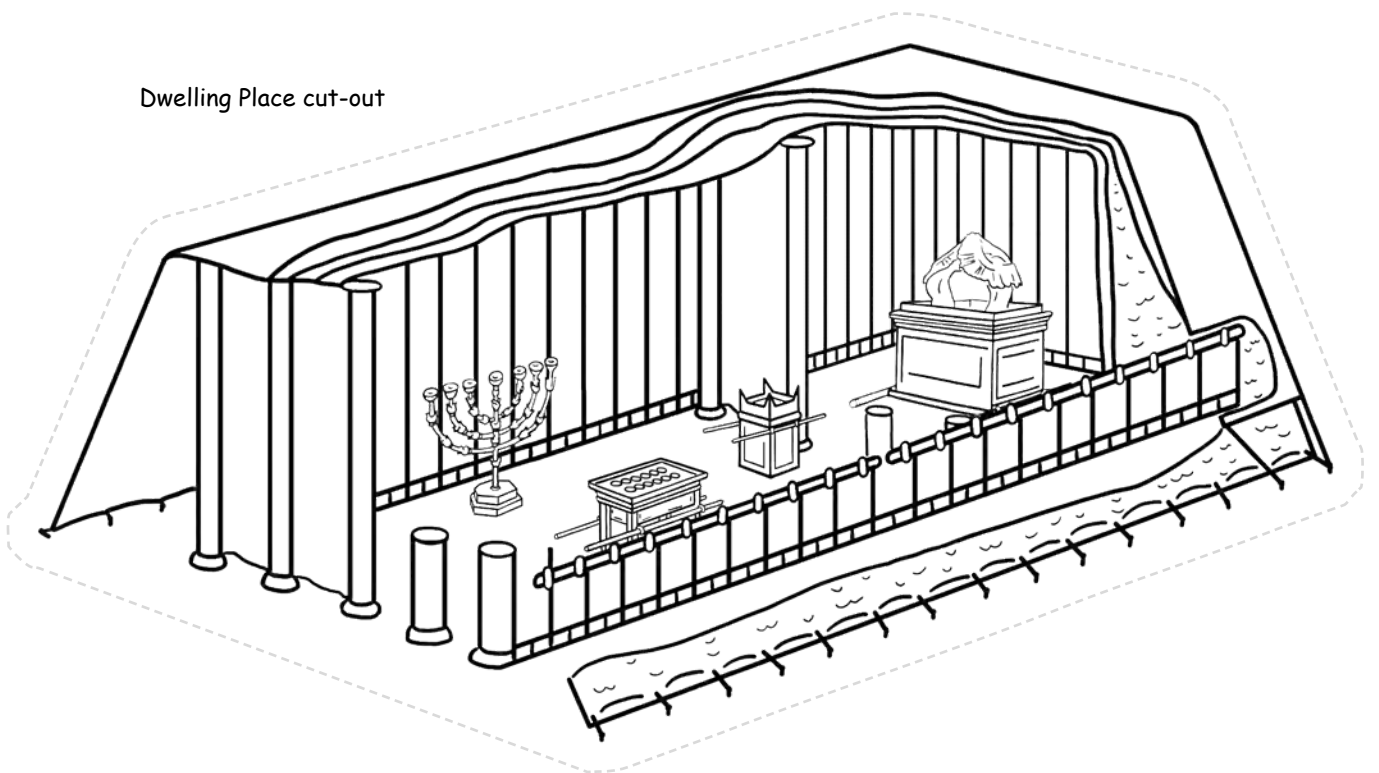



Mosheh anointing priests

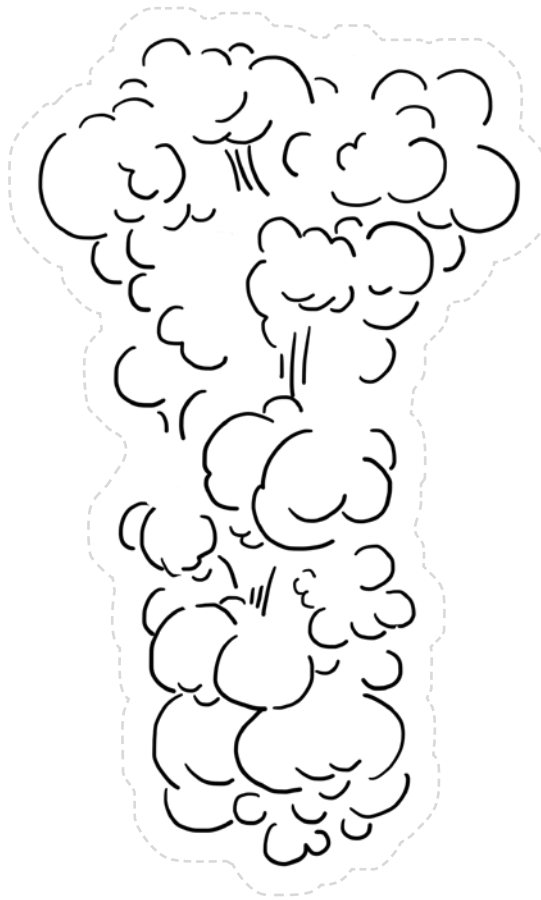

Pillar of cloud



Pillar of fire

Tent scene

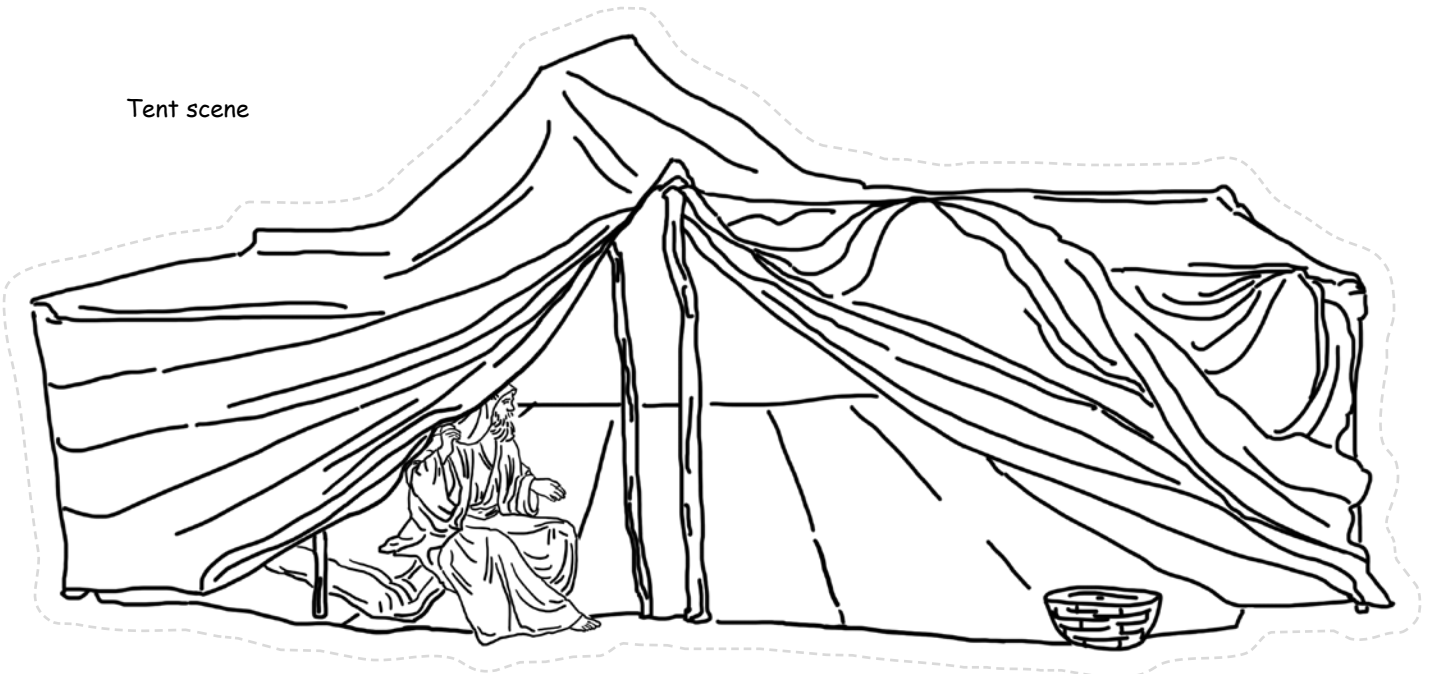

Counting What You Gained

This next section is intended to be reinforcement of the lessons learned during this parsha. Choose the activities that best fit your child.

STORING UP TREASURE IN MY HEART

The Katan Aleph memory verse for this Torah portion is Exodus 40:16. If they have not already done so, begin to help them to memorize the verse. Be creative and try acting it out, or putting it to music.

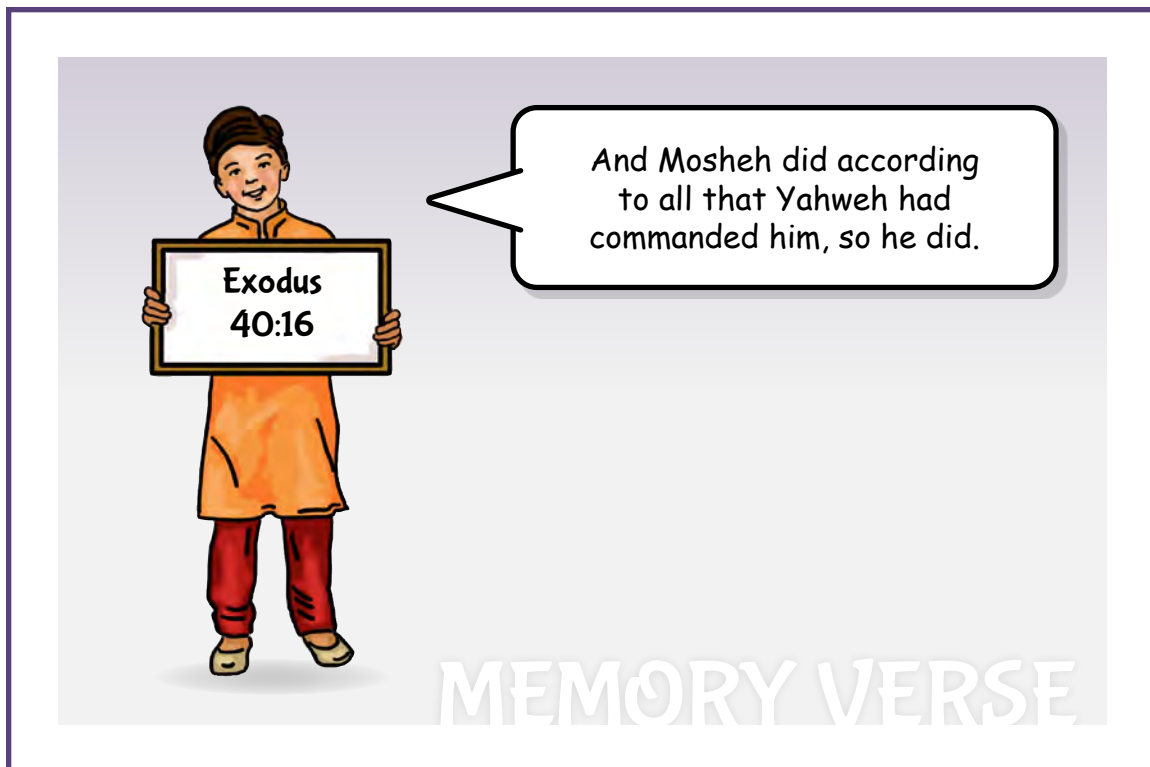

Use this space to draw a picture of the verse memorized.

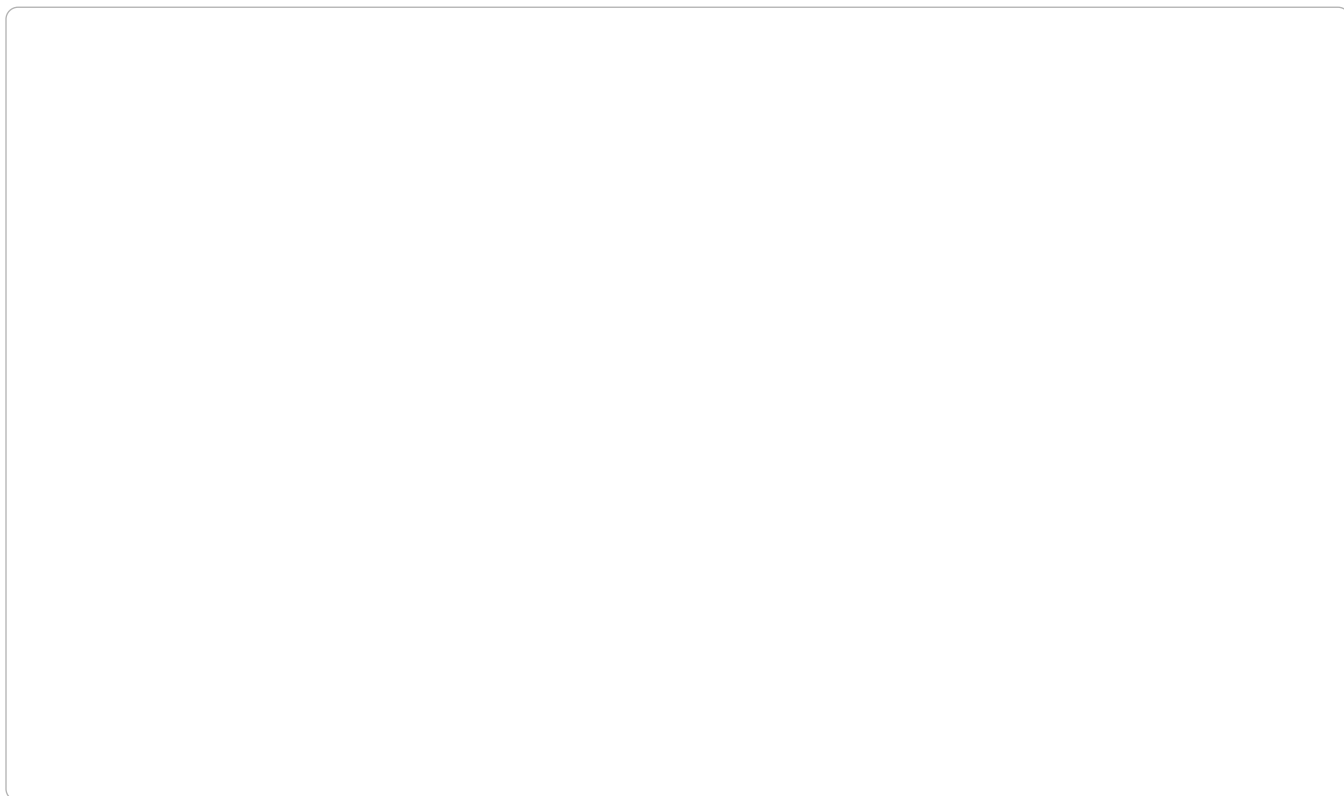

Use this space to write out the verse memorized.



SEEKING TREASURE

Circle the correct choices.

1. What piece of furniture was behind the inner veil in the Most Set-apart Place? (40:3)

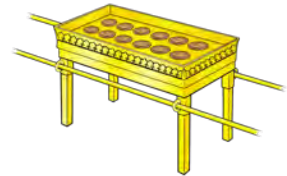
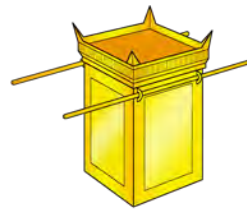

2. What furniture pieces were in the Set-apart Place? (40:4-6)

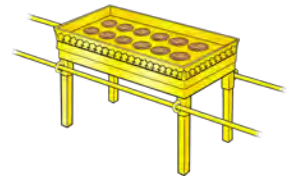
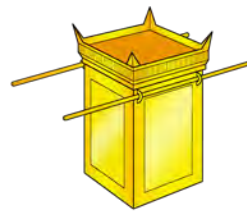

3. What furnishings were in the courtyard? (40:6-7)

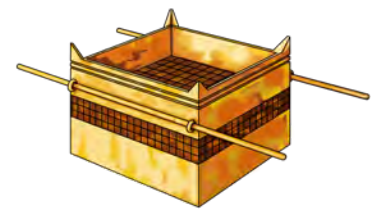

4. What type of oil was used to anoint all the furnishings and utensils of the Dwelling Place? (40:9)



5. What covered the Dwelling Place during the day? (40:38)

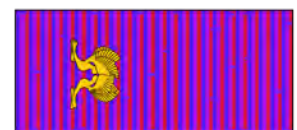

6. What covered the Dwelling Place during the night? (40:38)

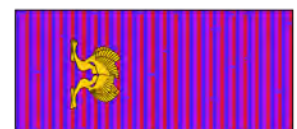

WORD SEARCH

Search for the hidden words from this week's parsha.



CLOUD
FIRE
DWELT
ESTEEM
JOURNEYS



MAZE

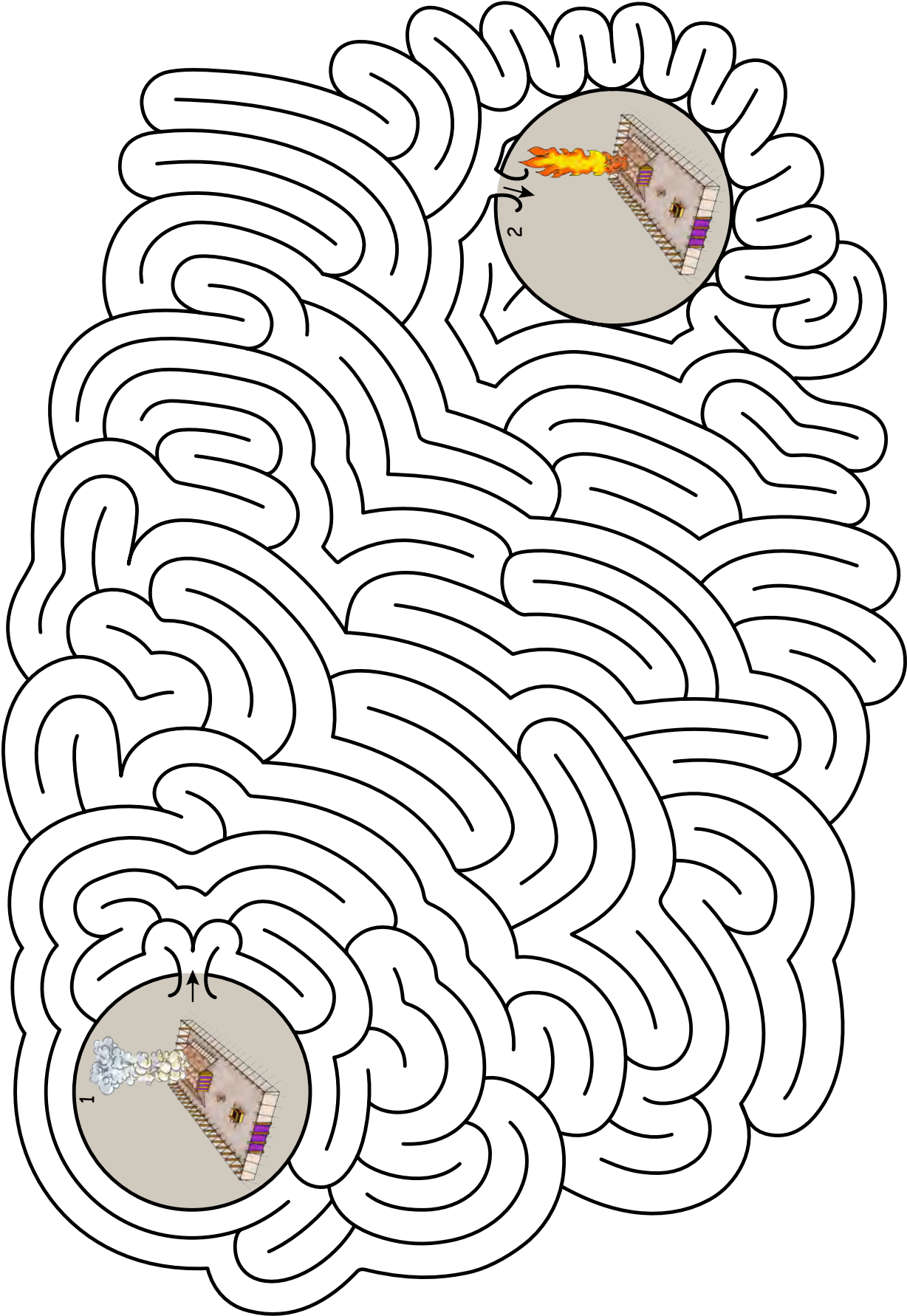

Precious Possessions

CRAFT

Materials:

- Cardstock - white
- Cotton balls (4-6)
- Dowel rod 12" x $\frac{1}{4}$ " (1)
- Tissue paper - red, orange
- Scissors
- Tacky Glue
- Pencil

Parent/Teacher Preparation:

- Review the steps and determine if you need to prepare some aspect in advance.

Pillar of Cloud & Pillar of Fire

Exodus 40:34-38

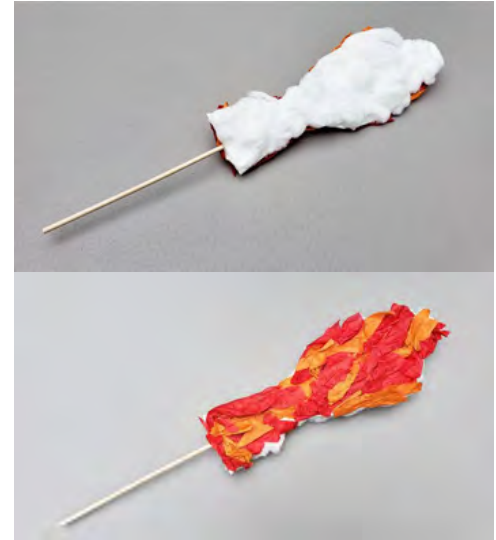

Instructions for the Craft:

- Use a pencil to trace around a closed hand and partway down the wrist on a sheet of cardstock. (P1)
- Get another sheet of cardstock and place the hand outline over it. Cut out 2 hands/wrists.
 - If hands are small enough you can put the hand to one side of the paper and then fold the paper in half the long way. Cut the 2 pieces together.
- Glue the rod onto the hand/wrist about halfway up from the bottom. (P2)
- Glue the second hand/wrist cut-out over the dowel making sure that matching sides are facing each other. (P3)



P1



P2



P3

Instructions for the Craft Cont'd:

Pillar of Cloud

- Take each cotton ball and gently pull it apart to make a wispy look.
- Glue the cotton balls to the other side of the paddle. (P4)
- Let it dry.

Pillar of Fire

- Tear small strips of red and orange tissue paper.
- Glue the strips, alternating colors, to the other side of the hand/wrist paddle. (P5, P6)
- Continue this process until the entire side is covered with tissue paper.

You now have a visual representation of the pillar of cloud by day and the pillar of fire by night that led the Yisra'elites in the wilderness.



P4



P5



P6

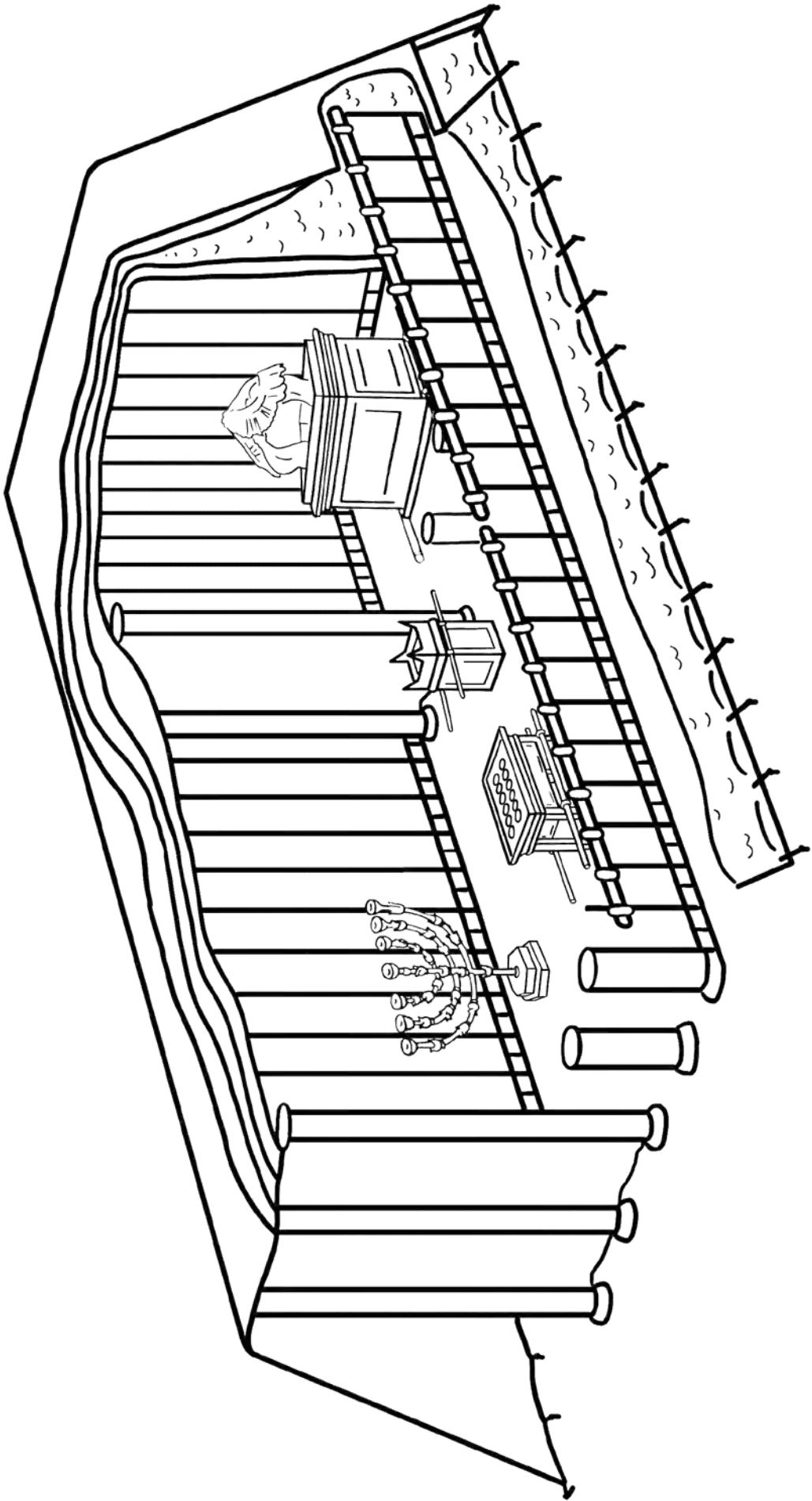

Sweetness of Torah

SWEET SOUNDS OF TORAH

(Sing Praises to His Name)

Here is the link for this song:

https://www.podomatic.com/podcasts/steveberkson/episodes/2017-03-19T06_56_21-07_00

Sing to the tune of "Mary Had a Little Lamb"

It is tradition to sing this song every time you finish a book of the Torah.

Chazak, Chazak V'nitchazek

Chazak, Chazak, v'nit-chazek, v'nit-chazek, v'nit-chazek
Chazak, Chazak, v'nit-chazek, be brave and be strong

We read five books of the Torah, the Torah, the Torah
We read five books of the Torah, and then we say chazak

Now we finished Exodus, Exodus, Exodus
Now we finished Exodus, and so we say chazak

Chazak, Chazak, v'nit-chazek, v'nit-chazek, v'nit-chazek
Chazak, Chazak, v'nit-chazek, be brave and be strong



SWEET TASTE OF TORAH

This snack relates to this week's parsha. Please take these as suggestions and make necessary changes based on your individual dietary needs.

Pillar of Cloud & Pillar of Fire

Exodus 40:34-38



Ingredients:

- Pretzel rods (2)
- Marshmallow fluff
- Red frosting (represents fire)
- Kosher mini marshmallows (represents cloud)

Instructions:

To make the pillar of cloud, adhere marshmallow fluff to the top 1/3 of a pretzel rod. Then place miniature marshmallows randomly around the rod.

Pipe small strips of red frosting on the other pretzel stick to create the look of the pillar of fire.

Next Week's Treasure Hunt

Next Week's Torah Portion



Suggested Reading Schedule

Monday:	Lev. 1	Burnt Offerings
Tuesday:	Lev. 2	Grain Offerings
Wednesday:	Lev. 3	Peace Offerings
Thursday:	Lev. 4	Sin Offerings
Friday:	Lev. 5	Sin and Guilt Offerings