

Parsha Pearls

Vayikra

"And He Called"

Leviticus 1:1 - 6:7
Katan Aleph



In This Edition:

24.1 - 3 Voluntary offerings — Instructions to the OFFEROR
Leviticus 1 - 3



Table of Contents

Parsha Pearls is a comprehensive resource that allows for complete customization by the parent. We understand that if you were to strive to accomplish all aspects of each lesson in one day it would be unrealistic and also overload for the child. It is our intention that this be used 'a la carte' so that it suits your specific needs. Our site caters to printing only the pieces you choose.

This page will provide quick links to get to the portion of the document for which you are looking. When you hover over the title a finger will appear. Click on it and you will be taken directly to that page.

If you are new to Parsha Pearls, we have created an [Introduction](#) document outlining how to use our lessons, as well as a [Scriptural Inspiration](#) document, which explains our titles and the Scriptural inspiration for them. We pray that Parsha Pearls blesses your home and that your children will grow to love the Word and to never depart from keeping Torah. As always, feel free to email us at parshapearls@mtoi.org if you have any questions.

➤ Vayikra Overview	3
Gem Seeking (The Main Lesson)	4
➤ Little Gems Story (Story for Younger Children)	4
➤ Little Gems Story Characters	7
Counting What You Gained (Worksheets)	15
➤ Storing Up Treasure in My Heart (Memory Verse)	15
➤ Seeking Treasure (Questions from the Parsha)	17
➤ Word Search	19
➤ Maze	20
Precious Possessions (Arts & Crafts)	21
➤ Craft	21
➤ Coloring Page	27
Sweetness of Torah	28
➤ Sweet Sounds of Torah (Song Corresponding to the Parsha)	28
➤ Sweet Taste of Torah (Snack Corresponding to the Parsha)	29
Next Week's Treasure Hunt (Looking Ahead to Next Week's Parsha)	30



VAYIKRA OVERVIEW

"And He called"... Vayikra

Today we are starting the 3rd book of the Torah, called Vayikra, meaning 'And He called.' The English name for this book is different from the Hebrew. It is called Leviticus, which means 'Book of the Levites' because the content has so much to do with Torah (services and rituals) pertaining to the Levitical priesthood.

We ended the book of Shemot/Exodus with the telling of the lifting up of the Dwelling Place and the cloud of Yahweh upon it during the day and fire upon it at night. Now that the Dwelling Place is built, the book of Leviticus starts off with Yahweh's instruction to the children of Yisra'el regarding the five types of offerings brought to the priesthood. As we study the book of Leviticus, we will read about the ordination ceremony of Aharon and his sons the priests. We will learn about clean and unclean foods, as well as the Torah for uncleanliness and the priest's roles. Torah regarding NOT following other nation's customs, as well as right-rulings for various topics will be covered. We will also learn about the feast Yom Hakippurim (Day of Atonements), the Sabbatical year and all of Yahweh's Appointed Times. Torah regarding the light for the lampstand and vows as well as voluntary offerings are explained as well.

Because each parsha is so rich in information, we will only be able to examine certain parts of each parsha per lesson. We do encourage parents and their children to do their own studies. In future years, we plan to fill in the pieces from each parsha that we did not cover previously.

Here is a breakdown of the 10 parashot in the book of Vayikra:

- Vayikra (And He called) - Ch. 1-5
- Tzav (Command) - Ch. 6-8
- Shemini (Eighth) - Ch. 9-11
- Tazria - (She conceives) - Ch. 12-13
- Metzora - (One being diseased) - Ch. 14-15
- Acharei Mot (After the death) - Ch. 16-18
- Kedoshim (Set-apart ones) - Ch. 19-20
- Emor (Say) - Ch. 21-24
- Behar - (On the Mount) - Ch. 25
- Bechukotai - (In My laws) - Ch. 26-27

We pray that you will be blessed as we begin our study in the 3rd book of the Torah. Let's dig in!

SHALOM FROM YMTOI/MTOI



Gem Seeking

LITTLE GEMS STORY

Parent/Teacher Preparation:

Please see the [Instructions for the Little Gems Story](#) on the YMTOI website. This will help you to understand how to prepare for the story.

3 Voluntary offerings – Instructions to the OFFEROR

Shalom children! In the book of Shemot, we were introduced to a man named Mosheh. **(Place Mosheh on board.)** We learned how he was protected by his mom from Pharaoh's hand and how he built such a relationship with Yahweh that he got to talk to Him as if they were friends. What an amazing thing!

Yahweh gave Mosheh the job of sharing with the people what Yahweh wanted him to say, and to teach them and guide them on the things Yahweh wanted them to do. **(Place group of people on board.)** As we move to the next book in the Torah, called Vayikra, we are going to learn about some of those things.

Yahweh told Mosheh to teach the children of Yisra'el about offerings. The first 3 that He told Mosheh about were called the voluntary offerings. This offering was given to Yahweh because you wanted to. Who here likes to receive presents? Raise your hand! **(Place presents on board.)** A voluntary offering is like giving an unexpected present to someone just because you care for them and want to show them that you appreciate them. I'm sure that receiving them made Him smile. **(Place happy emoji on board.)**

The first offering that we will learn about is called the Burnt Offering. It is called that because the animal being offered was totally burned up. The Burnt Offering must be male and perfect. It could be a bull, a ram or a goat. **(Place male animals on board.)** If you couldn't afford to bring one of those, Yahweh said you could bring turtledoves or pigeons. **(Place birds on board.)** No one got to eat this offering. It was given totally to Yahweh.

The person who brought the Burnt Offering always took it to the door of the Tent of Meeting. **(Place offeror bringing ram on board.)** He would put his hand on the head of the offering and kill it. **(Place offeror with hands on ram on board.)** Then he would give it to the priest. **(Point to priest.)** We will learn a lot more about the priest's job next week, but one of the jobs he had was to take the animal and place it on the altar. And there it would stay over the fire all night, until only its ashes were left. **(Place burnt up offering on board.)**

In His Word, Yahweh tells us that when He received these offerings as a person's freely given contribution, it smelled wonderful to Him. It was like a sweet fragrance that He could smell both with His nose and with His heart! Do you remember the time when the Yisra'elites brought all those contributions for building the Tabernacle? They gave so much that Mosheh had to tell them to stop. **(Place contributions scene on board.)** I'm sure that made Yahweh smile. **(Point to happy emoji.)**



(Remove all characters from board.)

Another voluntary offering that Mosheh taught the people about was called the Peace Offering. This offering was given to Yahweh to thank Him for all the goodness He had shown you, or perhaps for a vow or promise that you made to Yahweh. The Peace Offering was similar to the Burnt Offering. The person bringing the offering would bring it to the door of the Tent of Meeting just like the Burnt Offering. **(Place offeror bringing cow on board.)** Children, did you notice something different about this offering? Yes, this offering is a female. One big difference was that you could bring either a male or a female animal for this offering.

(Place male and female animals on board and point to them as you read.) It could be a bull or a cow, a billy goat or a nanny goat, a ram or a ewe sheep. Just like the Burnt Offering he would place his hand on the head of his offering and then kill it. The priests would then do their duty. **(Point to priest.)** Again, we will learn more about their job next week when we look at the duties of the priests.

(Remove all characters from board.)

The 3rd voluntary offering we are going to learn about was not of animals, but of grain from their fields. Children, do you know what grain is? Well, there are many types of grain, like wheat and barley. **(Place wheat and barley grain stalks on board.)** People take them and grind the little seeds into flour. The flour is what is used to make cakes, cookies, and bread. **(Place baked goods on board.)** Yummy! Yahweh said that the grain offering could be cooked or uncooked. **(Place cooked unleavened breads and uncooked lump on board.)**

The uncooked grain offering had some rules about it. Just like your parents and teachers have rules, Yahweh had very specific rules that the adults were to follow whenever they brought a grain offering to Yahweh. There were 3 ingredients that were required, and always had to be included for the grain offering. They were: fine flour, oil and frankincense. **(Place mixture on board and point to each item.)** The offeror brought a lump of the uncooked grain offering and handed it to the priest. **(Place offeror with lump in their hand and priest on board.)** Next week we will learn about what the priest did with it.

Yahweh also told them that they could bring a cooked grain offering, too. He gave rules about how it could be cooked. It could be cooked in a pot **(place stewing pot on board)** or made on a griddle **(place griddle on board)**, or it could be baked in an oven **(place oven on board)**. Now wait a minute! That can't be an oven; it looks like an ant hill or a miniature volcano! Well, guess what? The ovens in the middle of the wilderness didn't look like the ovens we have in our kitchens today. They built them on the ground with dirt and clay, and they baked their bread on the sides of the oven. Wow, that sounds like fun! I don't know about you, but just thinking about all of this bread has me feeling hungry. But we still have a little bit more to our story.



The cooked grain offering had a few rules. Yahweh told the people that the offering could NOT be baked with any leavening. **(Place leavening with 'x' on board.)** Leavening is what makes breads and cakes all nice and fluffy, like this. **(Point to baked goods.)** Breads and cakes without leavenings are flat, like this. **(Point to unleavened breads on board.)** Matzah is what we usually eat all week during the Days of Unleavened Bread. Oh, yes—one more thing that the grain offering could never have was honey. **(Place honey pot with 'x' on board.)** I wonder what Yahweh's reason was for this. One day we will get to ask Him.

Another grain offering was the first-fruits. This was the very first harvest that you gathered up. And because Yahweh wanted His people to show Him thankfulness, remembering that everything we get is from Him, this first-fruits grain offering was NOT of ripe, golden heads. It had to be young, green heads of grain, crushed. **(Place crushed heads on board.)** The first-fruits grain offering was also burned on the altar to Yahweh. **(Place altar with burning grain heads on board.)** Next week we will find out what the priests got to do with the grain offerings. Oh, one more thing Yahweh said about all grain offerings is that they had to be seasoned with salt. **(Place salt on board.)** I don't know about you, but I think salt makes everything taste better!

When Mosheh told the people all that they had to do, he gave them very specific details. And although we do NOT do those things now, we still want to learn about them. After all, Yahweh took the time to tell Mosheh about these things, and they were written down in the Scriptures for us. So, we should take the time to learn about them, and be thinking about what our wonderful King might want us to give up for Him today, so we can live in a way that gives Him pleasure!

Well children, we have come to the end of our story for today. We will see you next week for another exciting Little Gems story!





Mosheh



Priest

Offeror with lump
in their hand



Contributions scene



Crushed heads



Wheat and barley grain stalks

Cooked unleavened breads

Burnt up offering

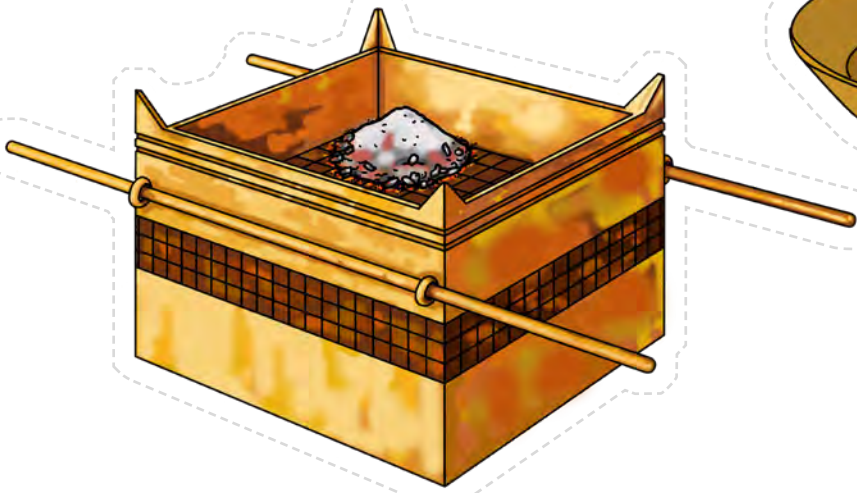

Presents

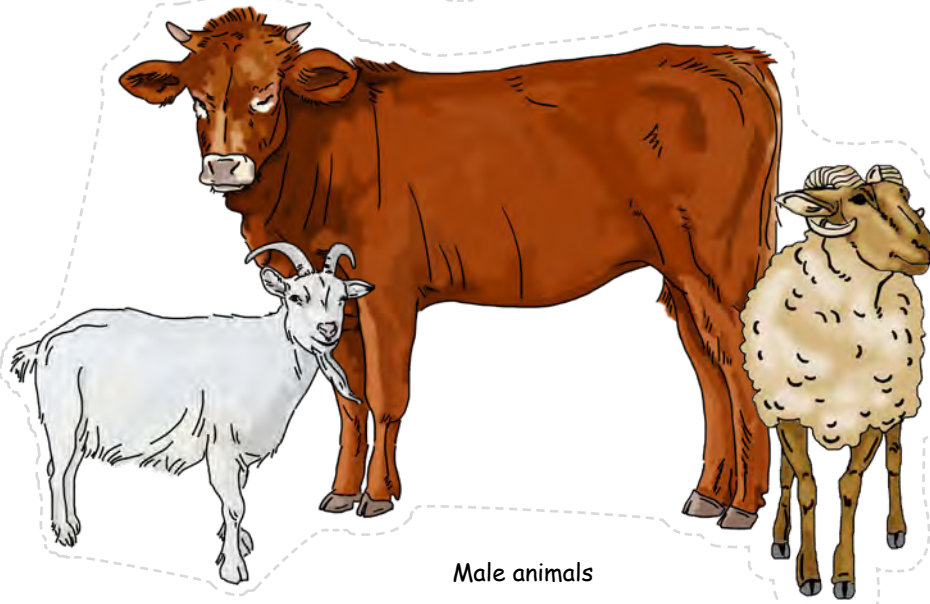
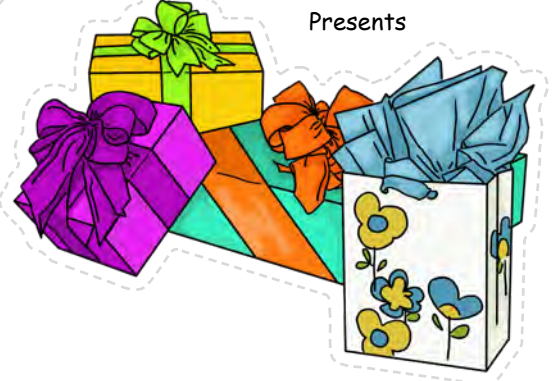

Male animals

Honey pot with 'x'



Baked goods

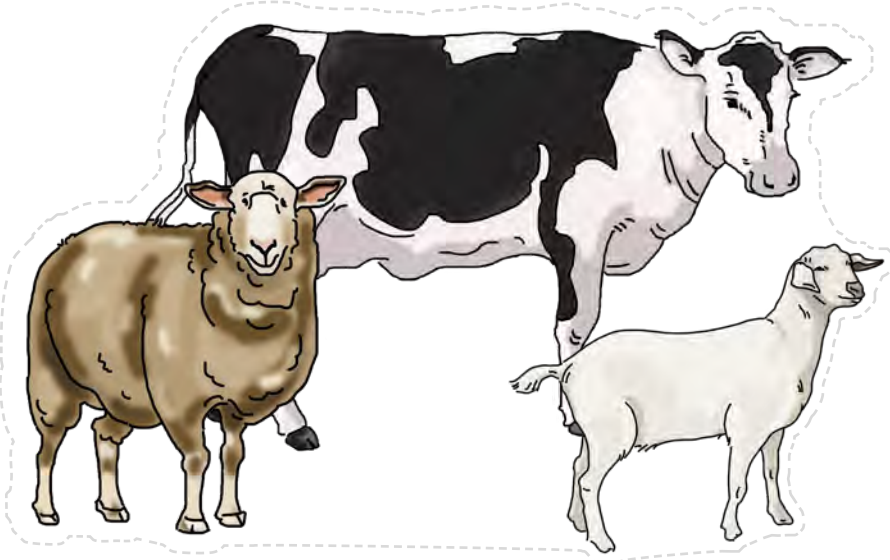

Female animals



Mixture



Group of people



Happy emoji

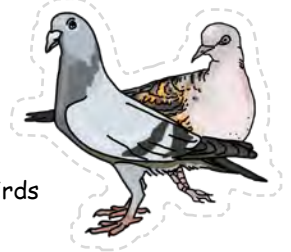

Birds



Stewing pot



Uncooked lump



Oven



Salt



Griddle



Leavening with 'x'

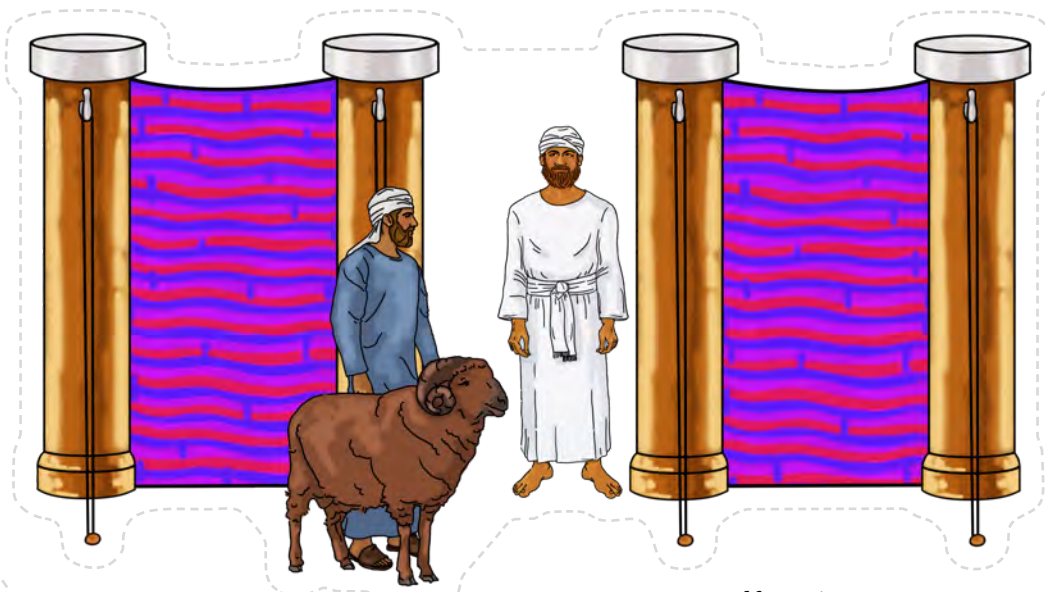

Offeror bringing ram

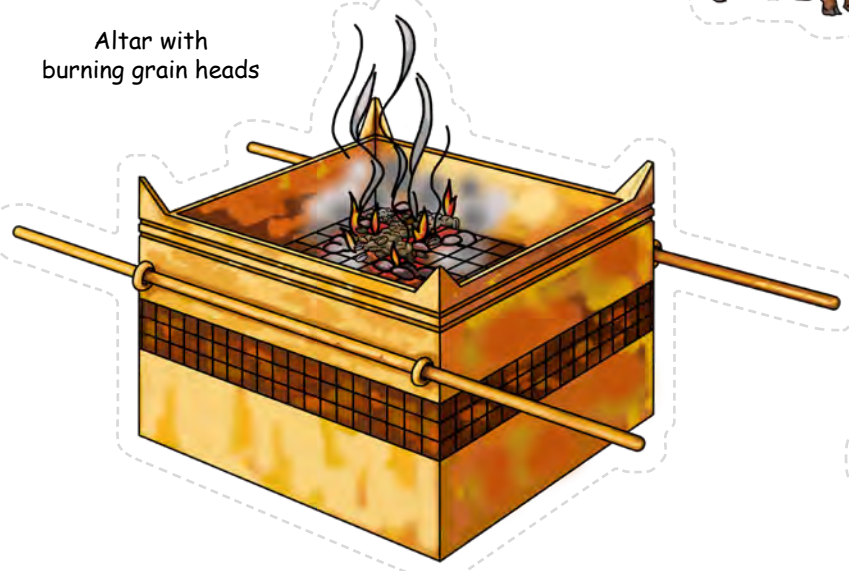

Altar with burning grain heads

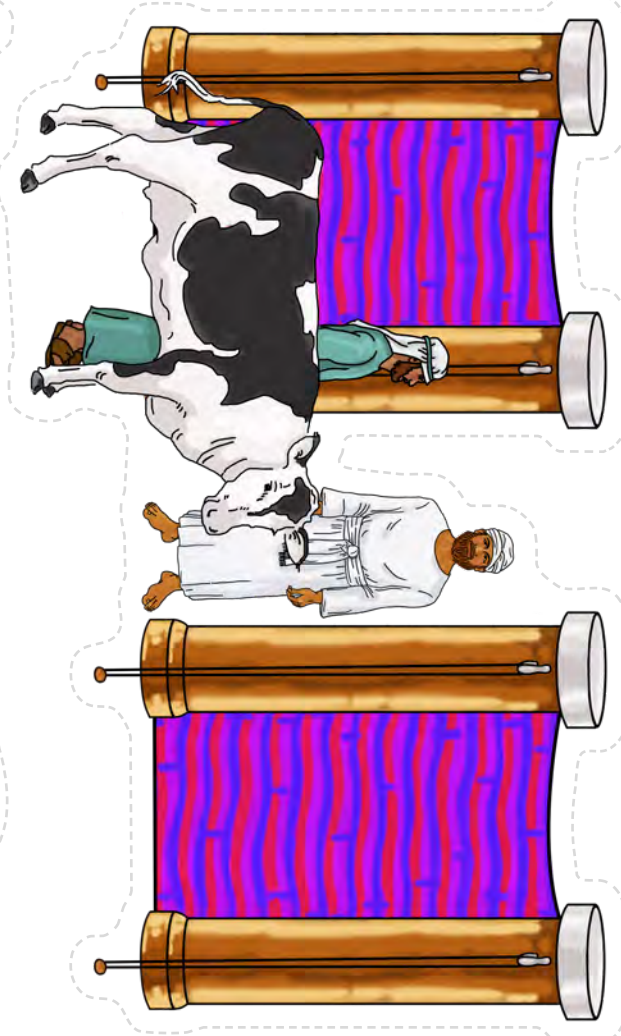

Offeror bringing cow

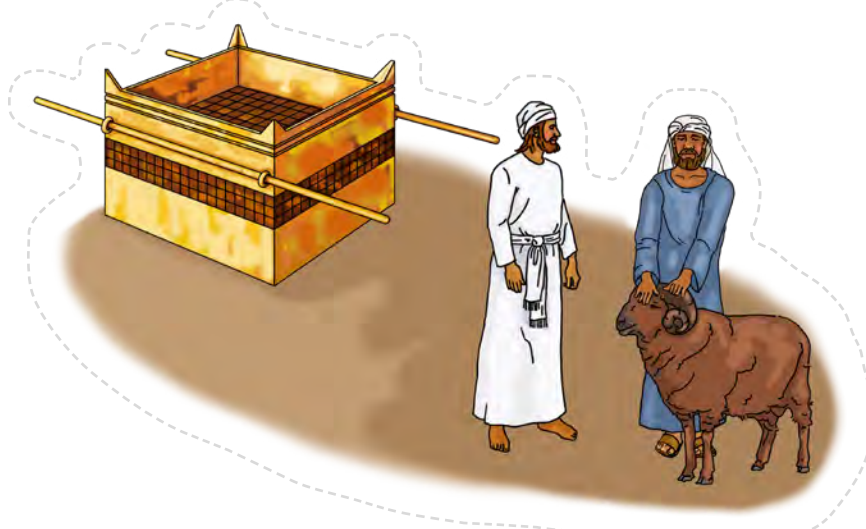

Offeror with hands on ram





Mosheh

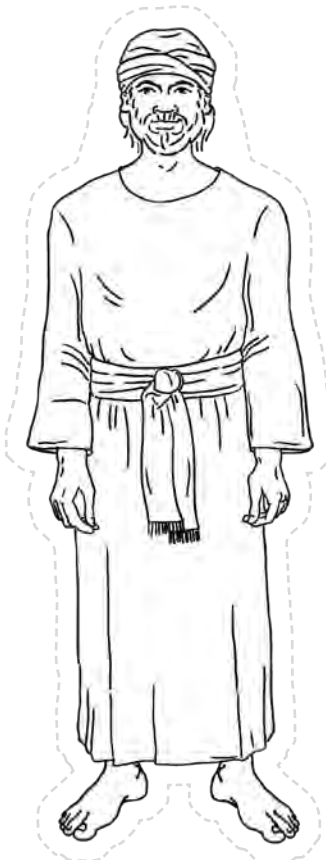

Priest

Offeror with lump
in their hand



Contributions scene

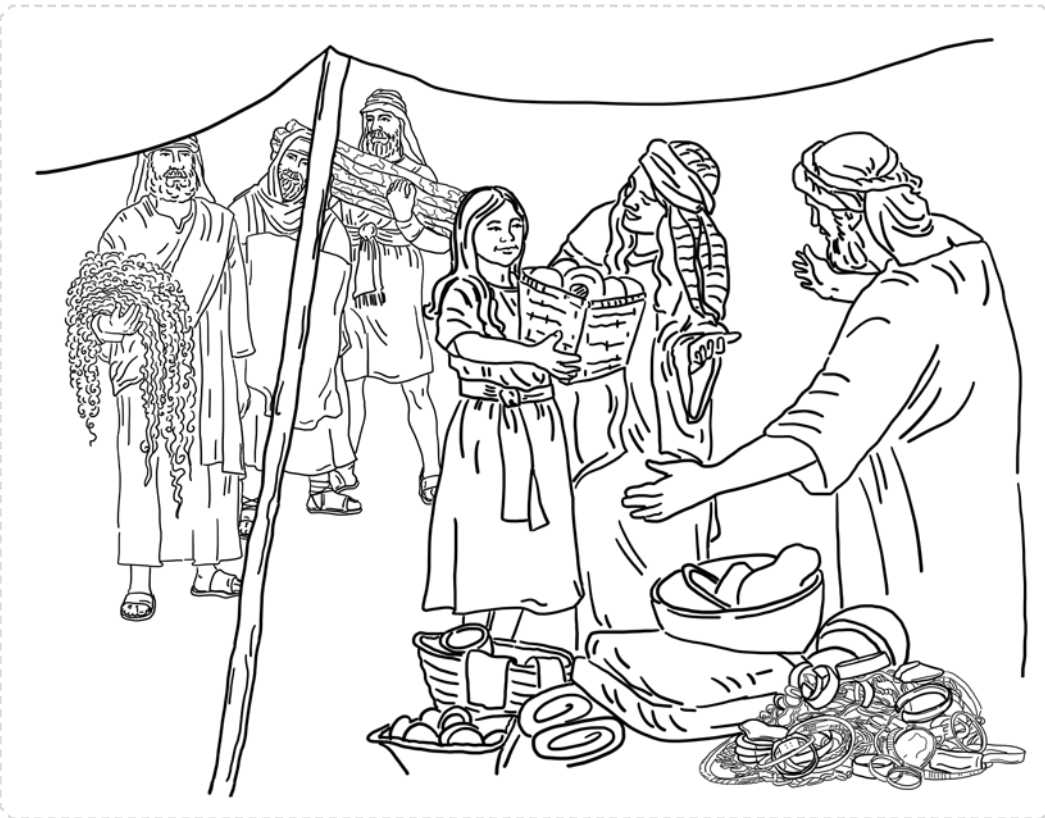

Crushed heads



Wheat and barley grain stalks

Cooked unleavened breads

Burnt up offering

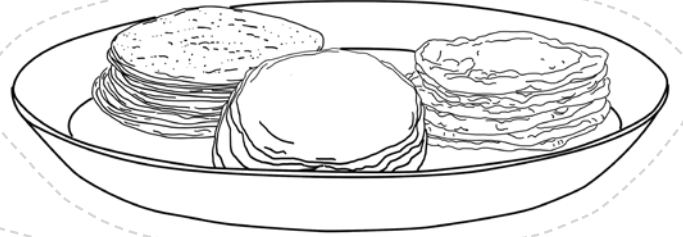
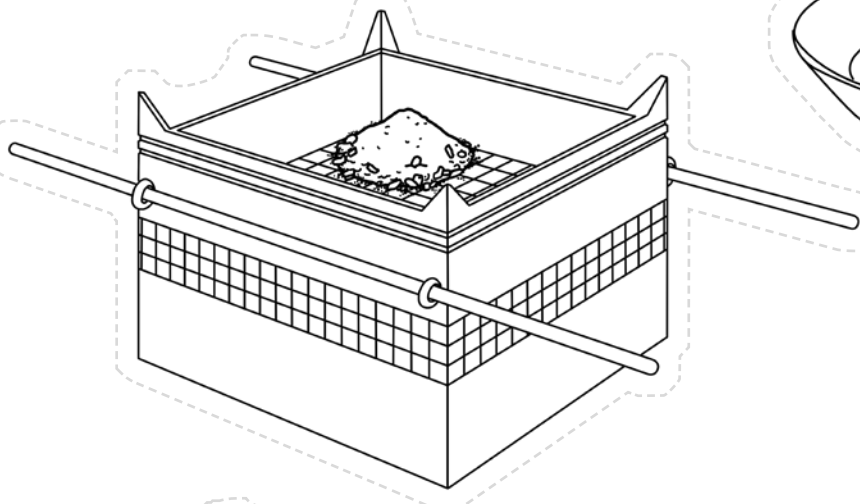

Presents

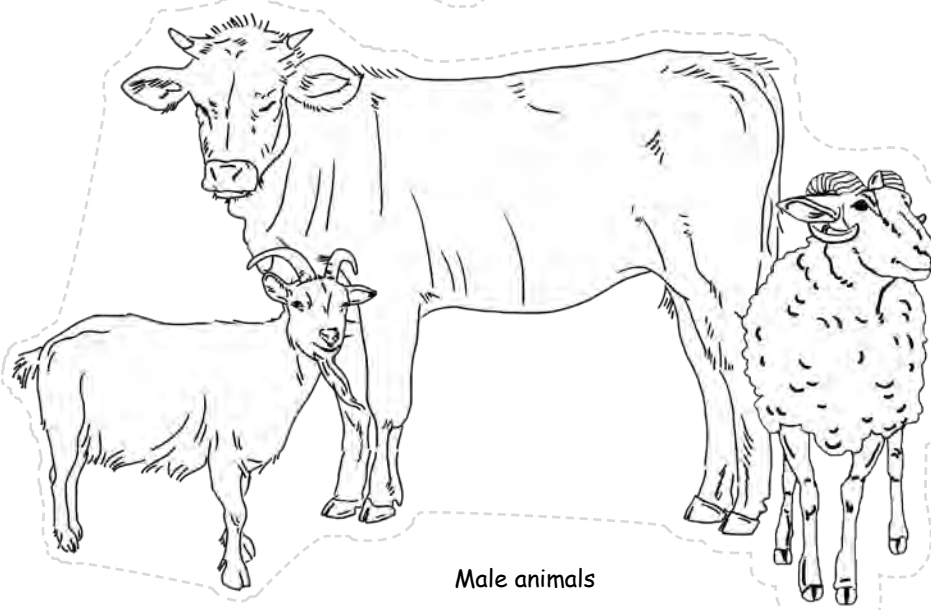
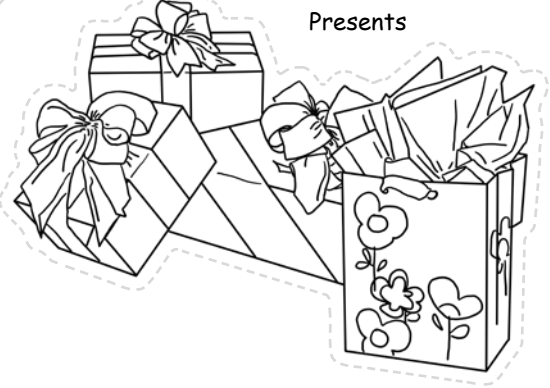

Male animals

Honey pot with 'x'



Baked goods

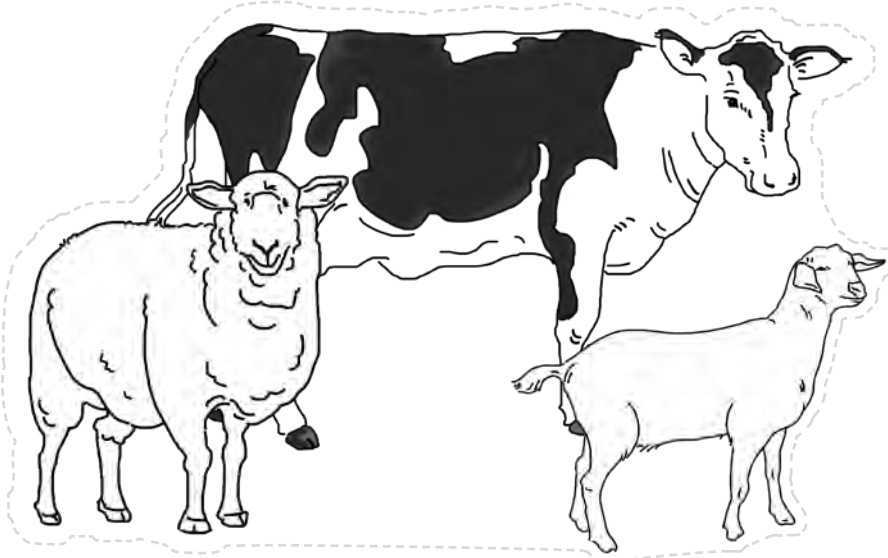
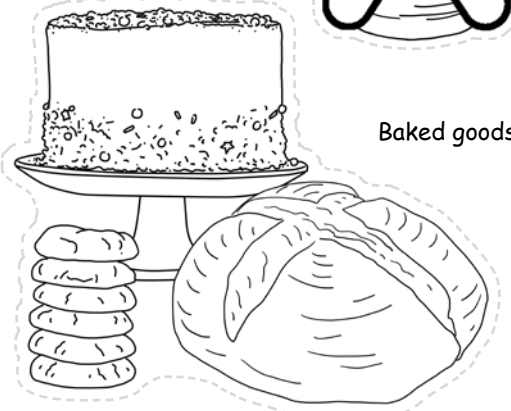

Female animals

Mixture



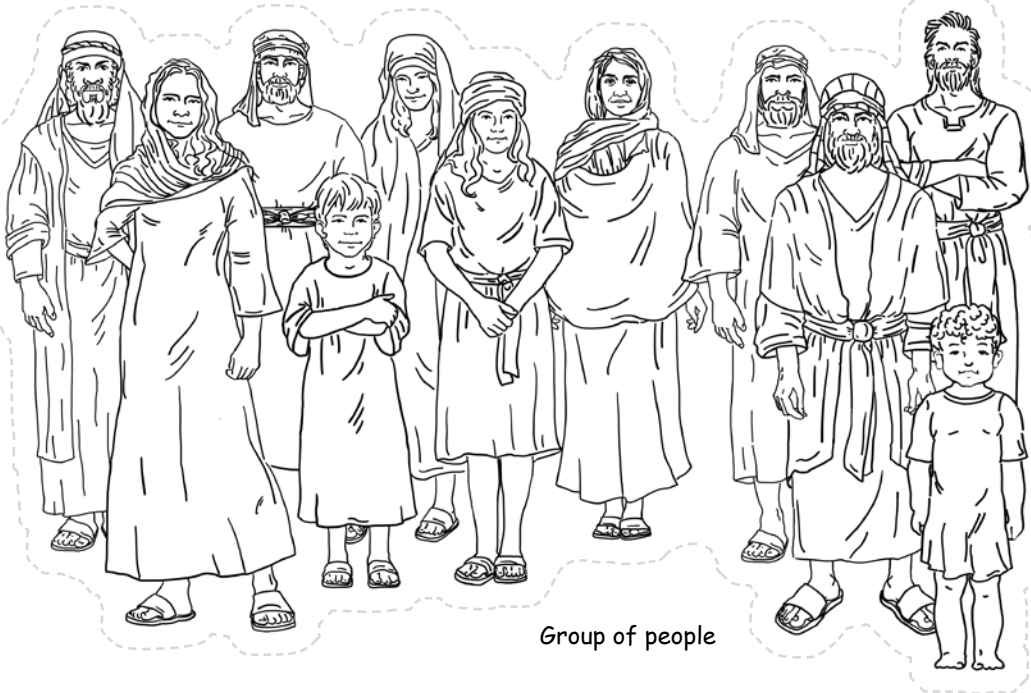

Group of people



Happy emoji

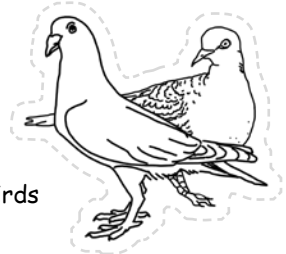

Birds

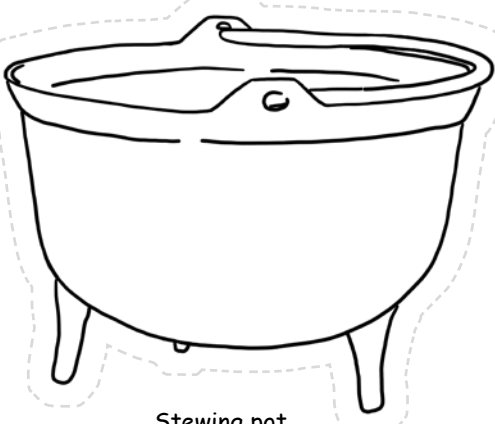

Stewing pot

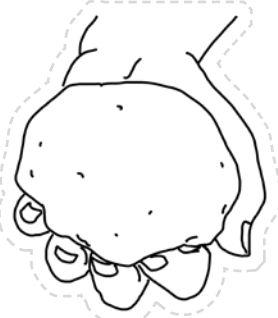

Uncooked lump

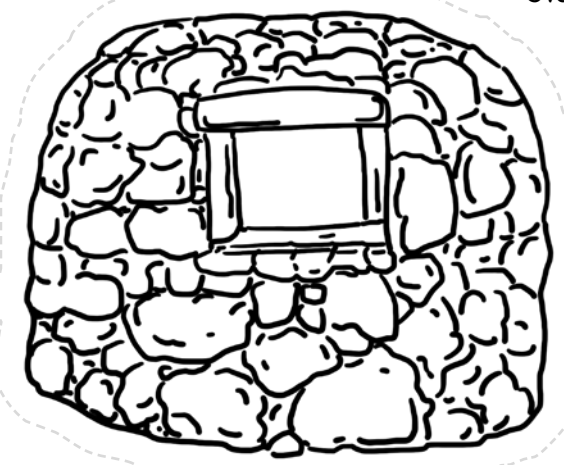

Oven

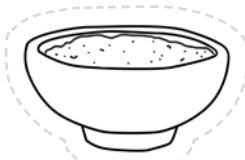

Salt

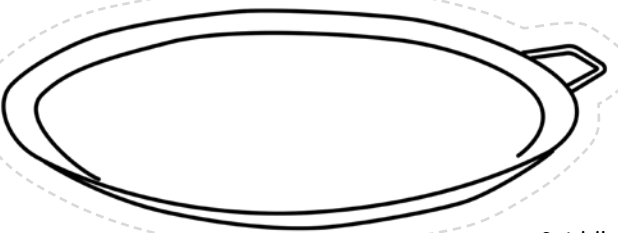

Griddle

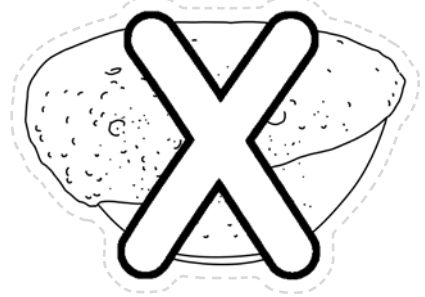

Leavening with 'x'

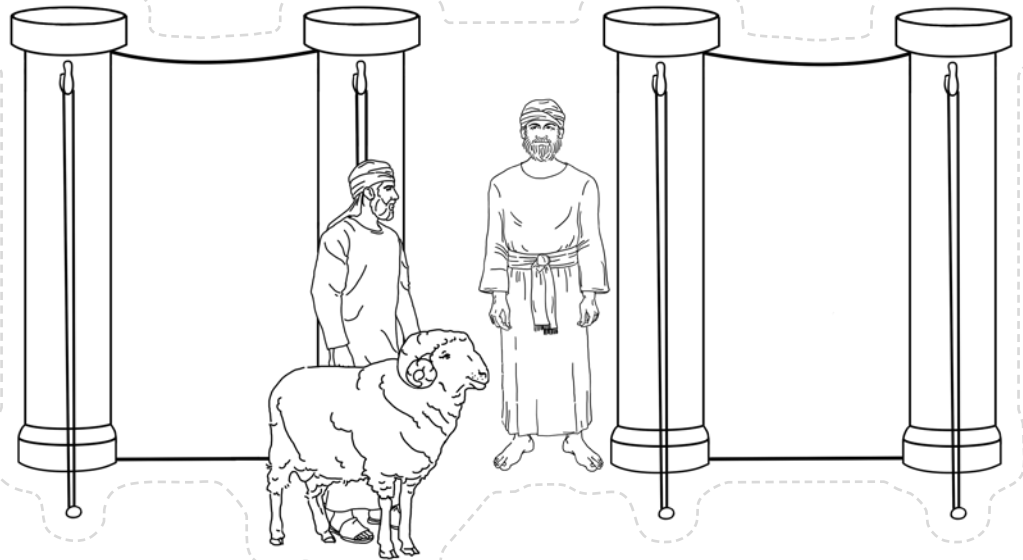

Offeror bringing ram

Altar with burning grain heads

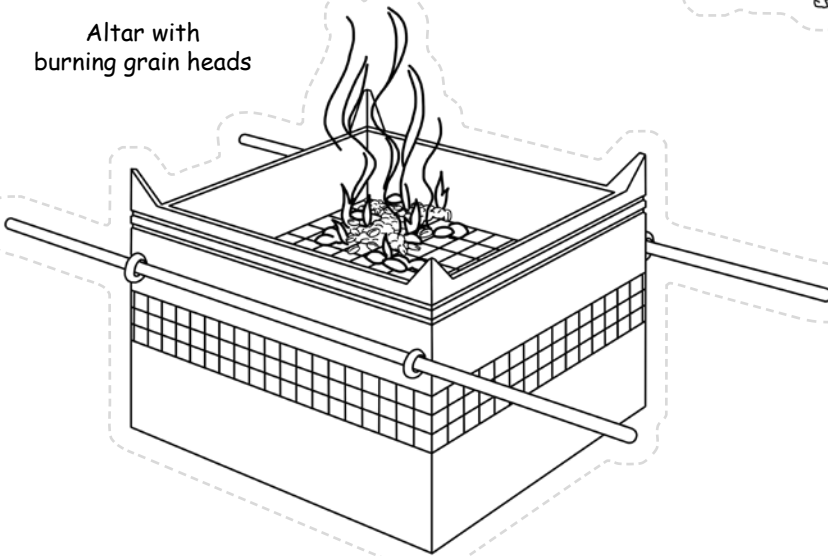

Offeror bringing cow

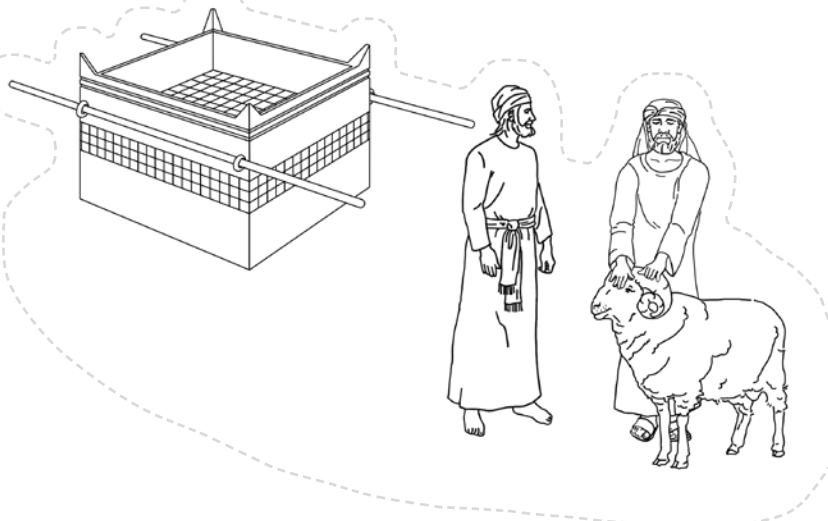
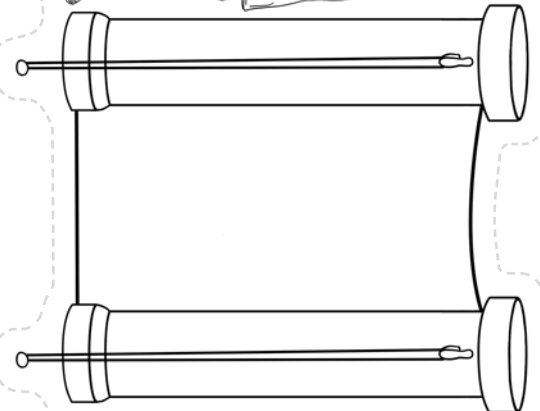
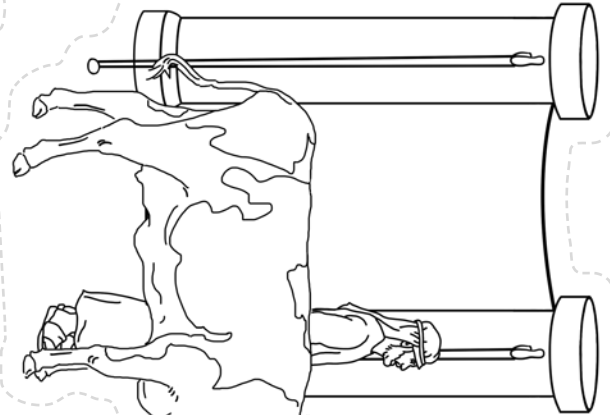

Offeror with hands on ram

Counting What You Gained

This next section is intended to be reinforcement of the lessons learned during this parsha. Choose the activities that best fit your child.

STORING UP TREASURE IN MY HEART

The Katan Aleph memory verse for this Torah portion is Leviticus 3:17. If they have not already done so, begin to help them to memorize the verse. Be creative and try acting it out, or putting it to music.

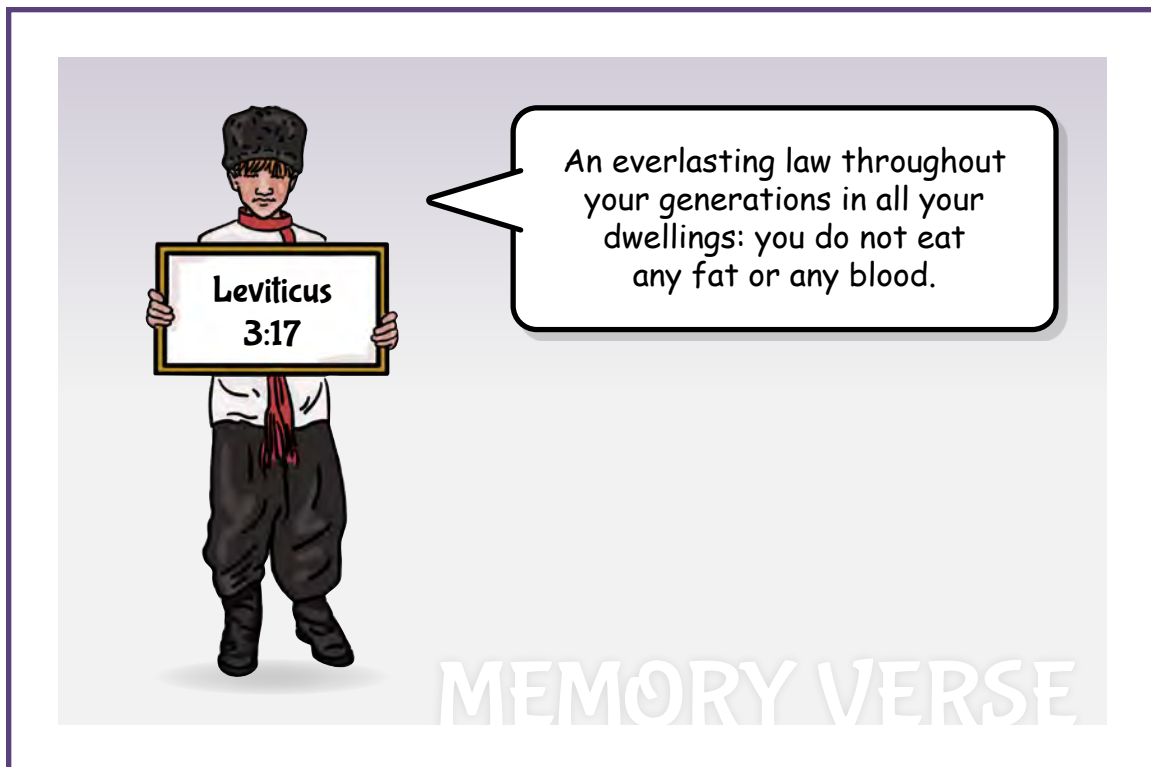

Use this space to draw a picture of the verse memorized.



Use this space to write out the verse memorized.

Handwriting lines consisting of 12 horizontal lines.



SEEKING TREASURE

Circle the correct choices.

1. Circle the wrong burnt offering. (1:5, 10-11)

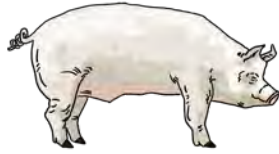

Pig

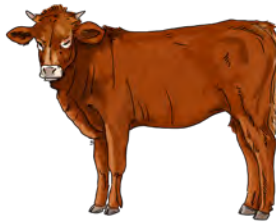

Cow



Ram



Goat

2. Circle the correct type of birds for the burnt offering. (1:14)



Eagle



Turtle dove



Raven



Pigeon

3. What 3 things must be brought for the uncooked grain offering? (2:1)



Fine flour



Honey



Oil



Frankincense

4. What 3 utensils can the cooked grain offering be cooked in? (2:4-5, 7)



5. What 2 items are not to be used with any grain offering? (2:11)



Fine flour



Honey



Oil



Yeast

6. What seasoning is to be used with every grain offering? (2:13)



Pepper



Salt

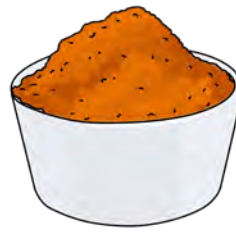

Turmeric



Ginger

7. Circle the wrong peace offering. (3:1, 6)

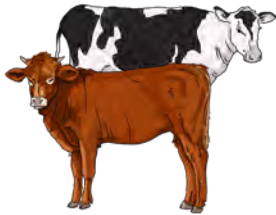

8. What 2 things are the children of Yisra'el commanded to never eat? (3:17)



Sugar



Blood



Salt

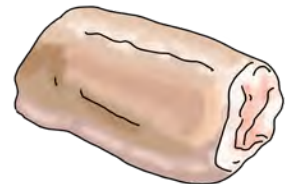

Fat

9. Where is the offeror to bring his offering? (1:3, 5; 3:2, 6, 13)



10. To whom is the offeror to bring his offering? (1:5, 11, 15, 17)



Mosheh



Yehoshua



Priest



Miryam

WORD SEARCH

Search for the hidden words from this week's parsha.

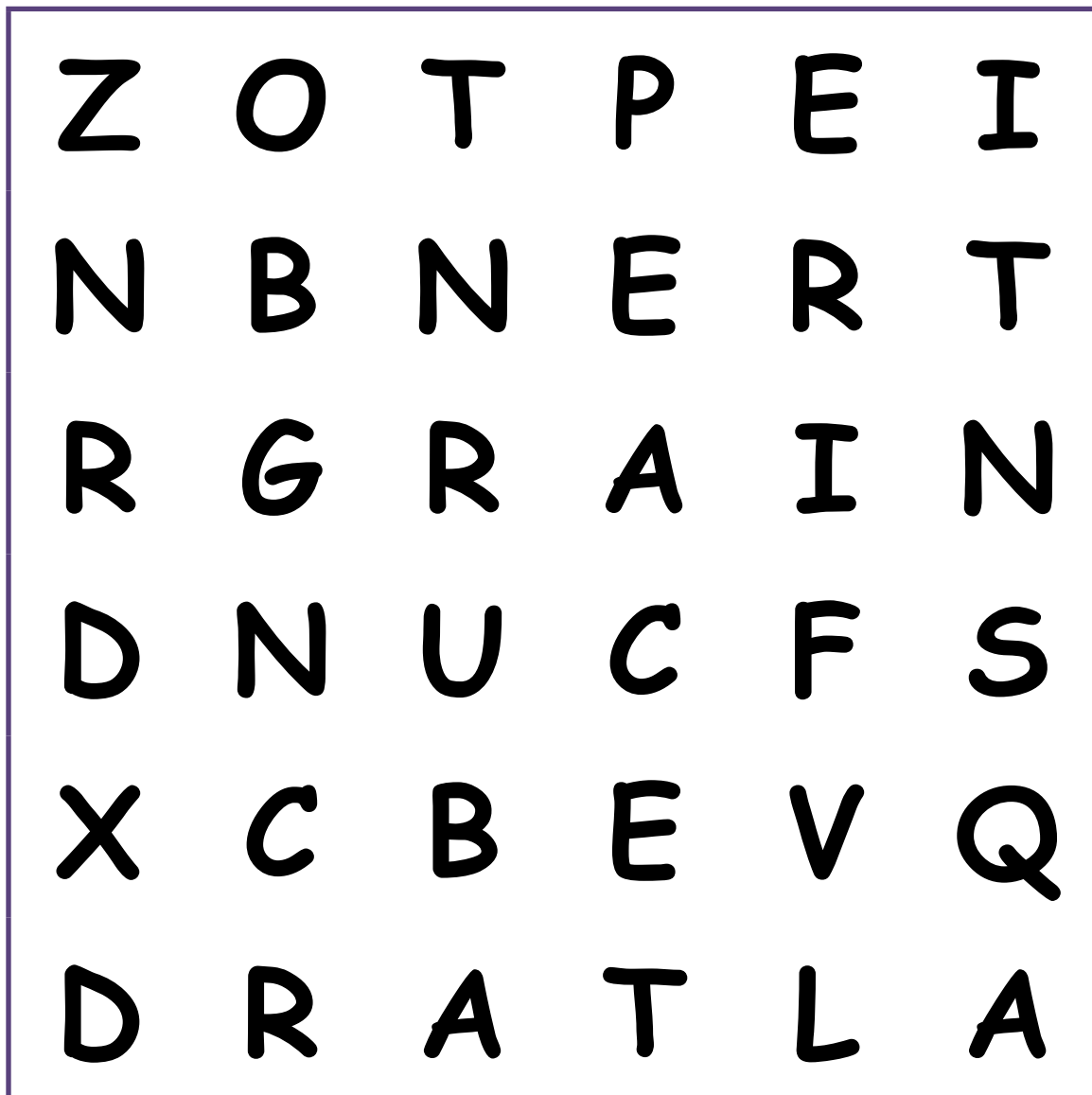

BURNT

GRAIN

PEACE

ALTAR

FIRE



MAZE

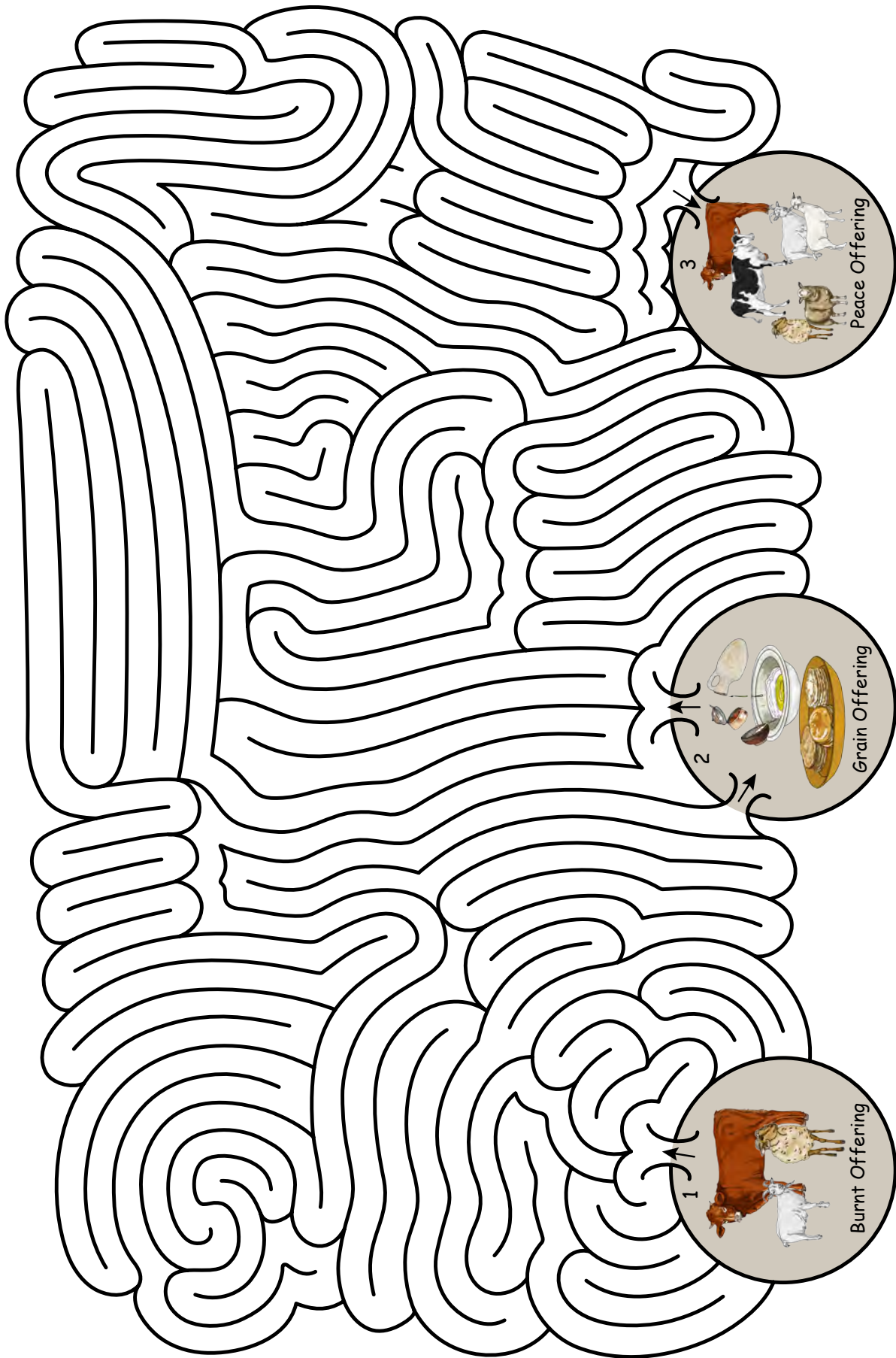

Precious Possessions

CRAFT

Special Note: You can choose to make any or all of the 4 sock puppets as desired. We recommend that you make one male and one female to depict the burnt offering as well as the peace offering. You can also make more sock puppets in upcoming parshas (Tzav or Shemini) or make the other animals the following parsha cycle.

Materials for Both:

- Cardstock - white
- Polymer stuffing
- Tiny rubber bands
- Wooden beads (4 per animal) - represents hooves
- Googly eyes (size of choice)
- Tweezers - to assist in placement of googly eyes
- Hot glue
- Permanent marker - thin (black)
- Scissors
- Craft Template: A

Materials for Bull/Cow:

- Chenille sock - black
- Black foam (for face)
- Pink foam (for nose)
- Pipe cleaners - black

Materials for Ram/Ewe:

- Chenille sock - white
- White foam (for face)
- Wooden beads (4 per animal) - represents hooves
- Pipe cleaners - white

Parent/Teacher Preparation:

- Print Craft Template A on cardstock.
- You may need to assist the child in pushing the pipe cleaners through the chenille socks.

Burnt (Olah) and Peace (Sh'lamim) Bull, Ram, Cow, Ewe Lamb Sock Puppets

Lev. 1:2-3;3:1



Instructions for the Craft:

- Cut out Template pieces (of choice). (P1)

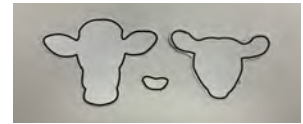

P1

Making the Bull/Cow Face

- Trace the face and nose templates onto black and pink foam and cut out. (P2)
- Using a thin black permanent marker, draw the nostrils on the bull/cow nose. (P3a, P3b)
- Glue the nose and googly eyes to the bull/cow head. Tweezers work well to assist in placement of googly eyes. (P4a, P4b)
- Allow to dry.



P2



P2

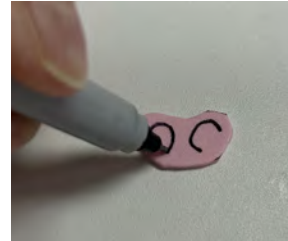

P3a



P3a

Making the Ram/Ewe Face

- Trace your template onto white foam and cut out. (P2)
- Using a thin black permanent marker, draw the nose and mouth on the ram/ewe. (P3a, P3b)
- Glue googly eyes to the ram/ewe. Tweezers work well to assist in placement of googly eyes. (P4a, P4b)

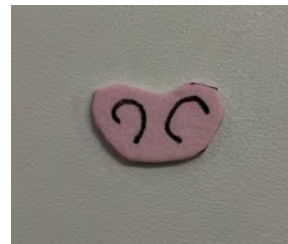

P3b



P3b



P4a



P4a



P4b



P4b

Instructions for the Craft Cont'd:

Making the Bull Horns

- Using a ruler, cut 1 black pipe cleaner 4" in length. (P5)
- Make a 'V' shape with the pipe cleaner. (P6)
- Using a glue gun, hot glue the horns onto the back of the bull's head. (P7a, P7b)
- Lay the bull or cow face aside for now. (P8a, P8b)



P5

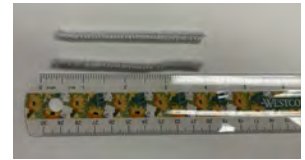

P5



P6



P6

Making the Ram Horns

- Using a ruler, cut 2 white pipe cleaners 4" in length. (P5)
- Bend the 2 pipe cleaners making ear shapes. (P6)
- Using a glue gun, hot glue the horns onto the back of the ram's head. (P7a, P7b)
- Lay the ram or ewe face aside for now. (P8a, P8b)



P7a



P7a



P7b



P7b



P8a



P8a



P8b



P8b

Instructions for the Craft Cont'd:

Making the Body of the Animals

- Stuff your chenille sock with polymer filling half full. (P9)
- Using a tiny rubber band, close off the body. (P10a, P10b)
- Take 2 pipe cleaners and lay over the body at the front and back to stage the legs. Make sure that the legs are even. (P11)
- Either before you push the pipe cleaners through the sock or after, take the hanging excess sock and fold it over the body about $\frac{3}{4}$ up the main body piece. This will create a band around the body and only reveal the part of the pipe cleaner that are the legs. We recommend that the end of the band be the back of the body.
- Push the ends of the 2 pipe cleaners through the socks on the sides of the front and back of the body to make the 4 legs. (P12a, P12b)
- Your body is now ready to add the hooves. (P13)



P9



P9



P10a



P10a



P10b



P10b



P11



P11



P12a



P12a



P12b



P12b



P13



P13

Instructions for the Craft Cont'd:

Attaching the Hooves

- Using a glue gun, hot glue the hooves onto the ends of the pipe cleaners. (P14a, P14b, P14c)
- Using a glue gun, hot glue the animal face onto the front of the body. (P15a, P15b)
- Your animals are now complete. (P16)

You now have a visual representation of some of the burnt and peace offering animals that were brought by the offeror to the priests as voluntary offerings.



P14a



P14a



P14b



P14b



P14c



P14c



P15a



P15a



P15b



P15b



P16



P16

Craft Template A

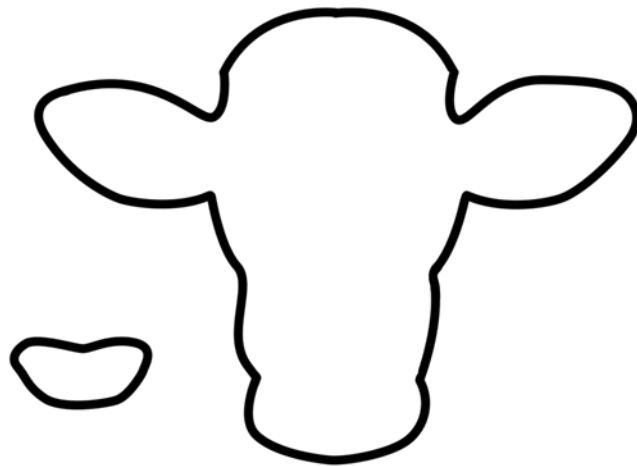
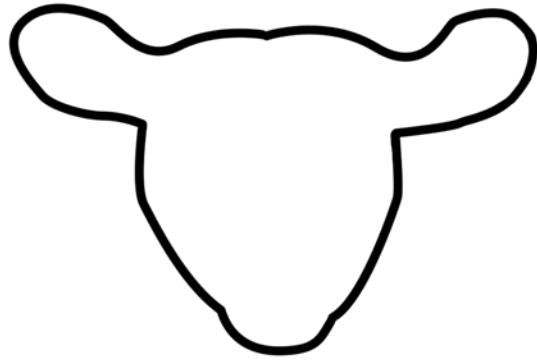

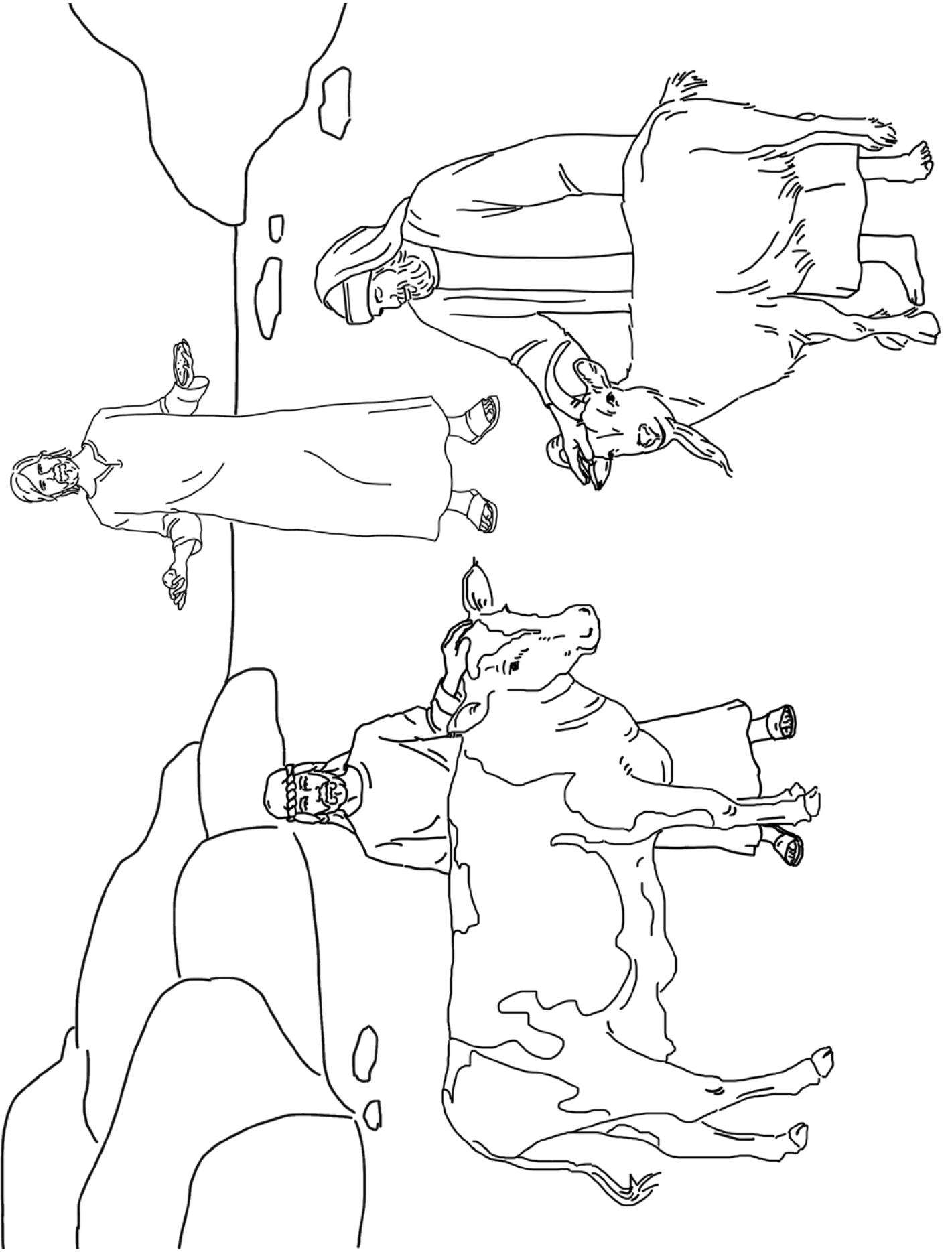

Sweetness of Torah

SWEET SOUNDS OF TORAH

(Sing Praises to His Name)

Here is the link for this song:

https://www.podomatic.com/podcasts/steveberkson/episodes/2017-03-26T05_12_47-07_00

The Korbanot

In the time of the mishkan
And the Beit Hamikdash too
Many korbanot were brought
To Yahweh by all Yisra'el

Chorus:

The Beit Hamikdash is no more
We have no korbanot as before
Now we study, now we pray
With our Scriptures every day

Mosheh taught that the korbanot
Were for them to become close
To Yahweh, so we understand
A korban was for the benefit of man

Chorus

A korban was a sacrifice
Love for Yahweh, it expressed
The korban was for teshuvah
To ask Yahweh's forgiveness

Chorus (repeat)

Mishkan - Dwelling Place
Beit Hamikdash - Holy Temple
Korbanot - offerings
Teshuvah - repentance (to turn around)



SWEET TASTE OF TORAH

This snack relates to this week's parsha. Please take these as suggestions and make necessary changes based on your individual dietary needs.

Edible Altar

Lev. 1:7;3:5



Ingredients:

- 5 Nutty Bars (represents altar)
- Pretzel Sticks (represents wood)
- Fruit Roll Up (represents fire)

Instructions:

Take one Nutty Bar and cut it in half. Take another Nutty Bar and cut 4 slices to represent the horns on the altar. Lay 2 complete bars length wise and place the bars that are cut in half in between them to make a square. Then, take your 4 cut slices and lay them on the edges of the altar upright. Take the pretzel sticks and lay them on the altar middle. Take pieces of a Fruit Roll Up and cut with food scissors to look like flames. Place as many as you like in between the pretzel stick wood.

Next Week's Treasure Hunt

Next Week's Torah Portion



Suggested Reading Schedule

Monday:	Lev. 6:8-30	Torah of Offerings: Burnt Offering; Grain Offering; Ordination Offering of Aharon and his sons on their day of anointing; Sin Offering
Tuesday:	Lev. 7:1-10	Torah of the Guilt Offering
Wednesday:	Lev. 7:11-21	Torah of the Peace Offering
Thursday:	Lev. 7:22-38	Torah regarding treatment of fat and blood; Peace Offering
Friday:	Lev. 8	The account of the anointing of Aharon and his sons, and their ordination offerings