

Beha'alotcha

"When You Ascend"

Numbers 8:1 - 12:16

Katan Aleph



In This Edition:

36.1 - Marching Orders
Numbers 9:15-23; 10:1-36



Table of Contents

Parsha Pearls is a comprehensive resource that allows for complete customization by the parent. We understand that if you were to strive to accomplish all aspects of each lesson in one day it would be unrealistic and also overload for the child. It is our intention that this be used 'a la carte' so that it suits your specific needs. Our site caters to printing only the pieces you choose.

This page will provide quick links to get to the portion of the document for which you are looking. When you hover over the title a finger will appear. Click on it and you will be taken directly to that page.

If you are new to Parsha Pearls, we have created an [Introduction](#) document outlining how to use our lessons, as well as a [Scriptural Inspiration](#) document, which explains our titles and the Scriptural inspiration for them. We pray that Parsha Pearls blesses your home and that your children will grow to love the Word and to never depart from keeping Torah. As always, feel free to email us at parshapearls@mtoi.org if you have any questions.

Gem Seeking (The Main Lesson)	3
➤ Little Gems Story (Story for Younger Children)	3
➤ Little Gems Story Characters	5
Counting What You Gained (Worksheets)	15
➤ Storing Up Treasure in My Heart (Memory Verse)	15
➤ Seeking Treasure (Questions from the Parsha)	17
➤ Word Search	19
➤ Maze	20
Precious Possessions (Arts & Crafts)	21
➤ Craft	21
➤ Coloring Page	22
Sweetness of Torah	23
➤ Sweet Sounds of Torah (Song Corresponding to the Parsha)	23
➤ Sweet Taste of Torah (Snack Corresponding to the Parsha)	24
Next Week's Treasure Hunt (Looking Ahead to Next Week's Parsha)	25



Gem Seeking

LITTLE GEMS STORY

Parent/Teacher Preparation:

Please see the [Instructions for the Little Gems Story](#) on the YMTOI website. This will help you to understand how to prepare for the story.

Marching Orders

Shalom children! Today, we will hear a story about a cloud and some trumpets. I like looking up at the clouds in the sky, and I like hearing trumpets, don't you? This cloud in our story wasn't just any old cloud, though, and these weren't just any old trumpets.

This cloud was a special cloud, because this was Yahweh's way of showing the Yisra'elites where He wanted them to camp. **(Place Yisra'elites on board.)** The Yisra'elites were in the Wilderness of Sinai, and this cloud was covering the Dwelling Place. **(Place Dwelling Place and pillar of cloud over the Dwelling Place on board.)** It stayed over the Dwelling Place all the time.

When it was night time, from evening until morning, it looked like fire. **(Remove cloud and place pillar of fire on board.)** And in the daytime, it went back to looking like a cloud. **(Remove fire and place cloud back on board.)** Whenever the cloud would move, the Yisra'elites would follow it to the new location, where they would set up camp again. **(Move cloud, Yisra'elites, and Dwelling Place to the other side of the board.)** And that is where they would stay until the next time the cloud moved. Sometimes the cloud would not move for a while. It would stay there above the Dwelling Place for a few days, or a month, or even a whole year! Until the cloud moved again, they would just stay put and be careful to guard the responsibilities that Yahweh had given them.

Now Yahweh directed Mosheh to make 2 silver trumpets to be used for gathering everyone together, and also for letting them know when it was time to take down the camp. **(Place Mosheh and 2 silver trumpets on board, not near the Dwelling Place.)** He told Mosheh that when both trumpets were blown together, everyone in the congregation was to meet at the door of the Tent of Meeting. But if only one trumpet was blown, then just the leaders would gather together. When they blew a shout, it would be time for the camps on the east side to leave. When they blew a shout the second time, the camps on the south side would leave. But if they wanted everyone to gather together, they would blow, but would not make it a shout. The special job of blowing the trumpets was given by Yahweh to the priests. **(Place sons of Aharon blowing trumpets on board.)**



The trumpets weren't just for gathering people together, though. When they were going to a battle, they could blow a shout on the trumpets, and Yahweh would save them from foreign people who didn't like them. The priests were also to blow them during the appointed times, during the new moon, and over their offerings to Yahweh. **(Place appointed times scene and offerings scene on board.)**

(Remove all items from board.)

Well, soon after Yahweh had told them all this, the cloud lifted from above the Dwelling Place and moved to the Wilderness of Paran. **(Place pillar of cloud on the right side of the board to make enough room for the line-up.)** This happened in the twentieth day of the second month, in the second year. So the Yisra'elites followed the cloud, according to all the instructions they had been given. They left in the order they were told to leave. The camp of Yehudah, Yissaskar and Zebulun took their banner and departed first. **(Place Group 1 behind the cloud.)** Next, the sons of Gershon and Merari departed with the Dwelling Place which was their job. **(Place Group 2 next in the procession carrying board and curtain.)** After they got on their way, it was time for the camp of Re'uben along with Shim'on and Gad to leave. So they took their banner and started walking. **(Place Group 3 on board next in line.)** The Qehathites departed after them, carrying the set-apart objects that went in the Dwelling Place. **(Place Group 4 next in line carrying set-apart objects.)** The camp of Ephrayim then took their banner and departed next along with Menashsheh and Binyamin. **(Place Group 5 next in the procession.)** And finally, the camp of Dan took their banner and departed last along with the camps of Asher and Naphtali. They were the ones who guarded the back of the procession. **(Place Group 6 at the end of the line.)** Each tribe had someone who was in charge of their army, so they were very organized and knew exactly who was supposed to be going with whom.

Mosheh encouraged Hobab, the son of his father-in-law, to come with them to the land of Kena'an. **(Place Hobab and Mosheh on board.)** Hobab wanted to return to his own land to be with his relatives, but Mosheh talked him into coming, and convinced him to serve as their scout. So they all set out to search for their new campsite. They followed the cloud for 3 days. Whenever the ark would set out, Mosheh would say, "Rise up, Oh Yahweh! And let Your enemies be scattered and let those who hate You flee before You." And whenever the ark rested, Mosheh would say, "Return, Oh Yahweh, to the countless thousands of Yisra'el."

Well children, we have come to the end of our story for today. We will see you next week for another exciting Little Gems story!



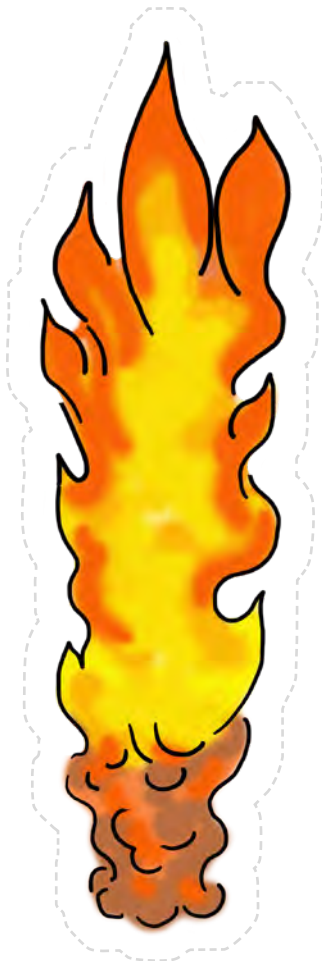

Pillar of fire

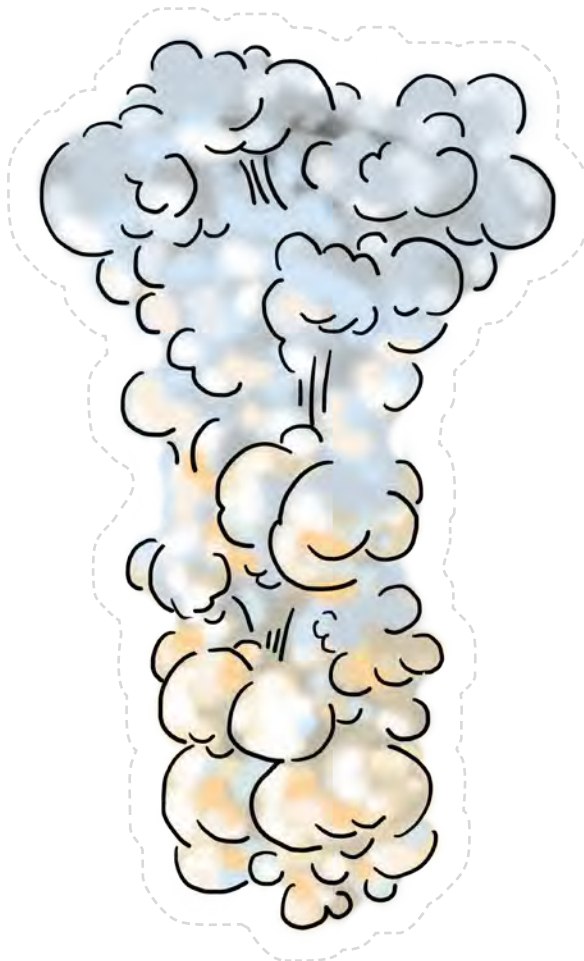

Pillar of cloud



Sons of Aharon blowing trumpets

Group 2

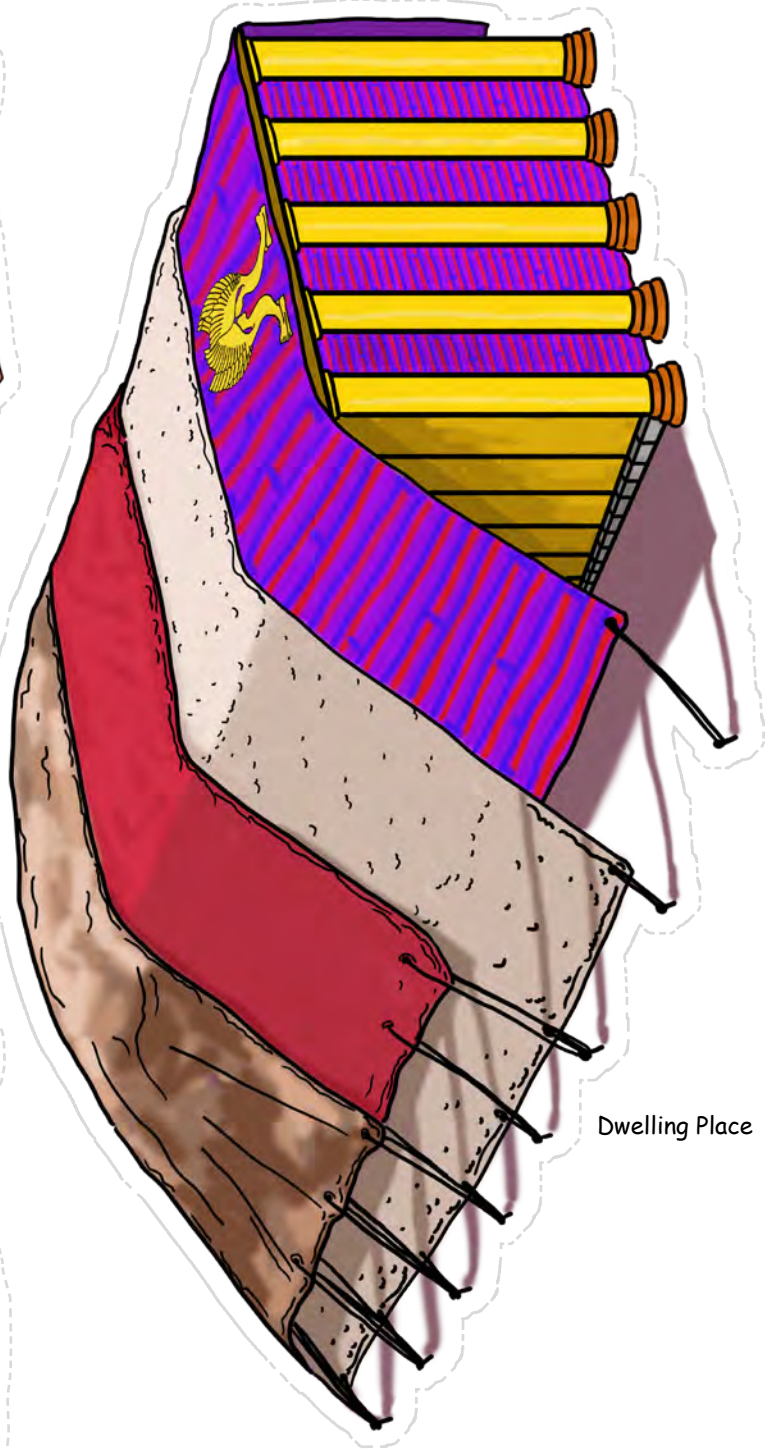
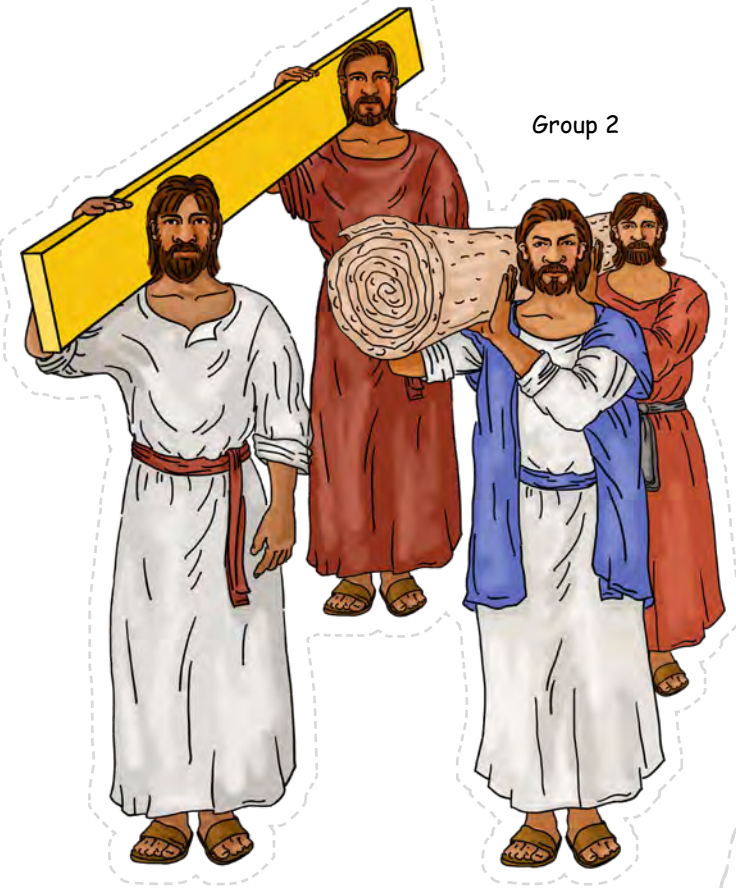

Dwelling Place

Group 4

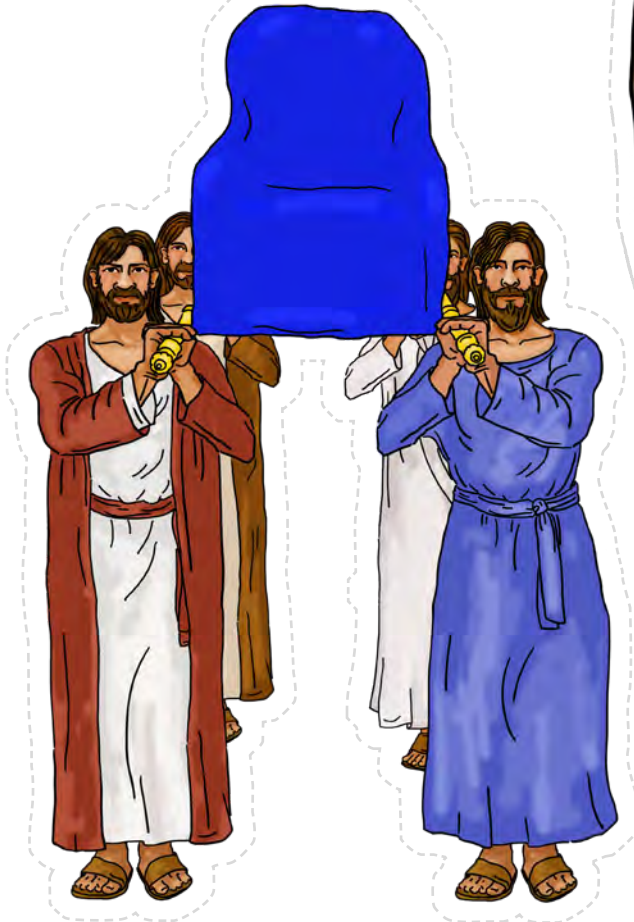

Offerings scene

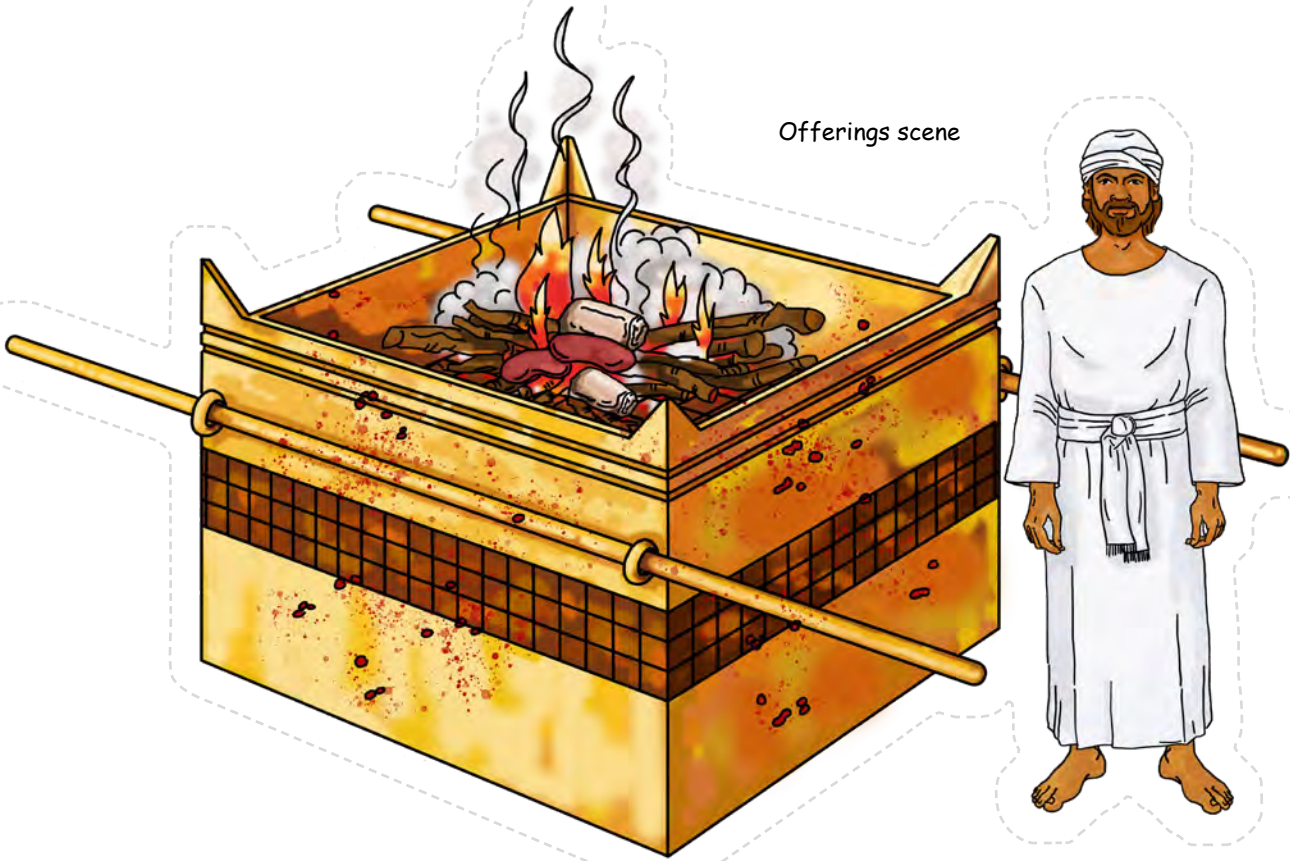

Yisra'elites

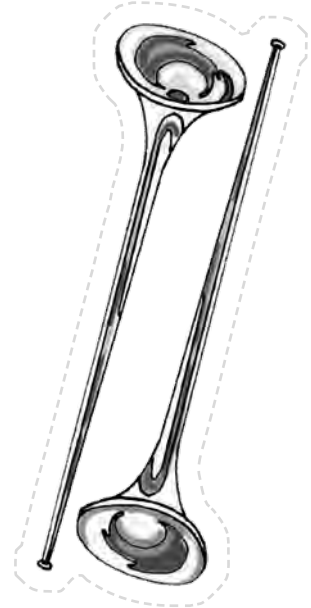

2 Silver trumpets



Group 5



Hobab

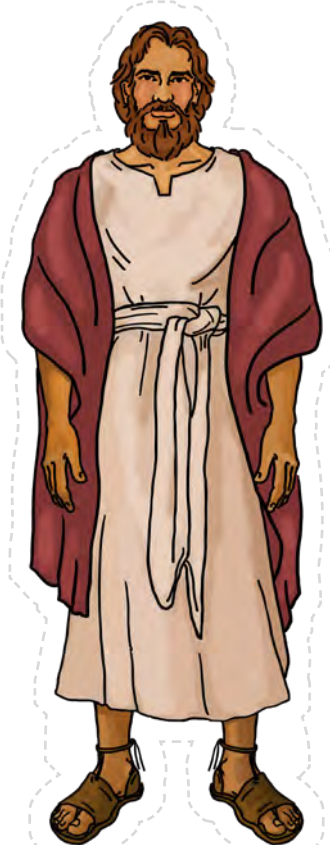

Mosheh

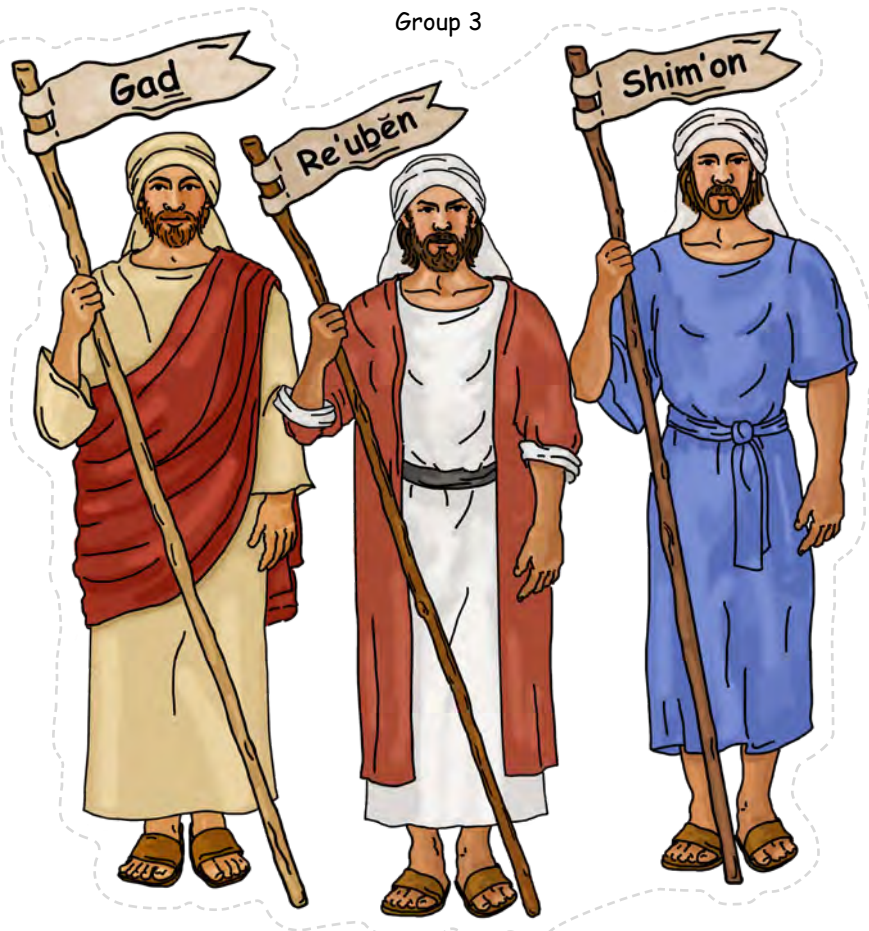

Group 3

Appointed
Times scene

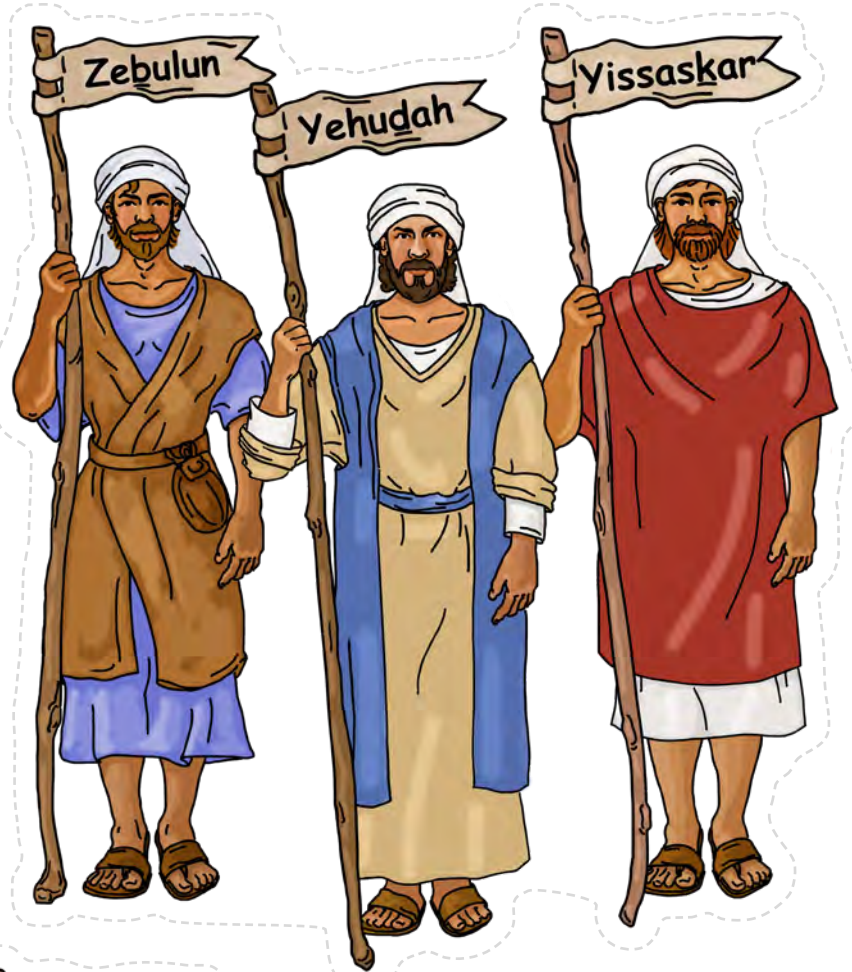

Group 1



Group 6





Pillar of fire



Pillar of cloud



Sons of Aharon blowing trumpets

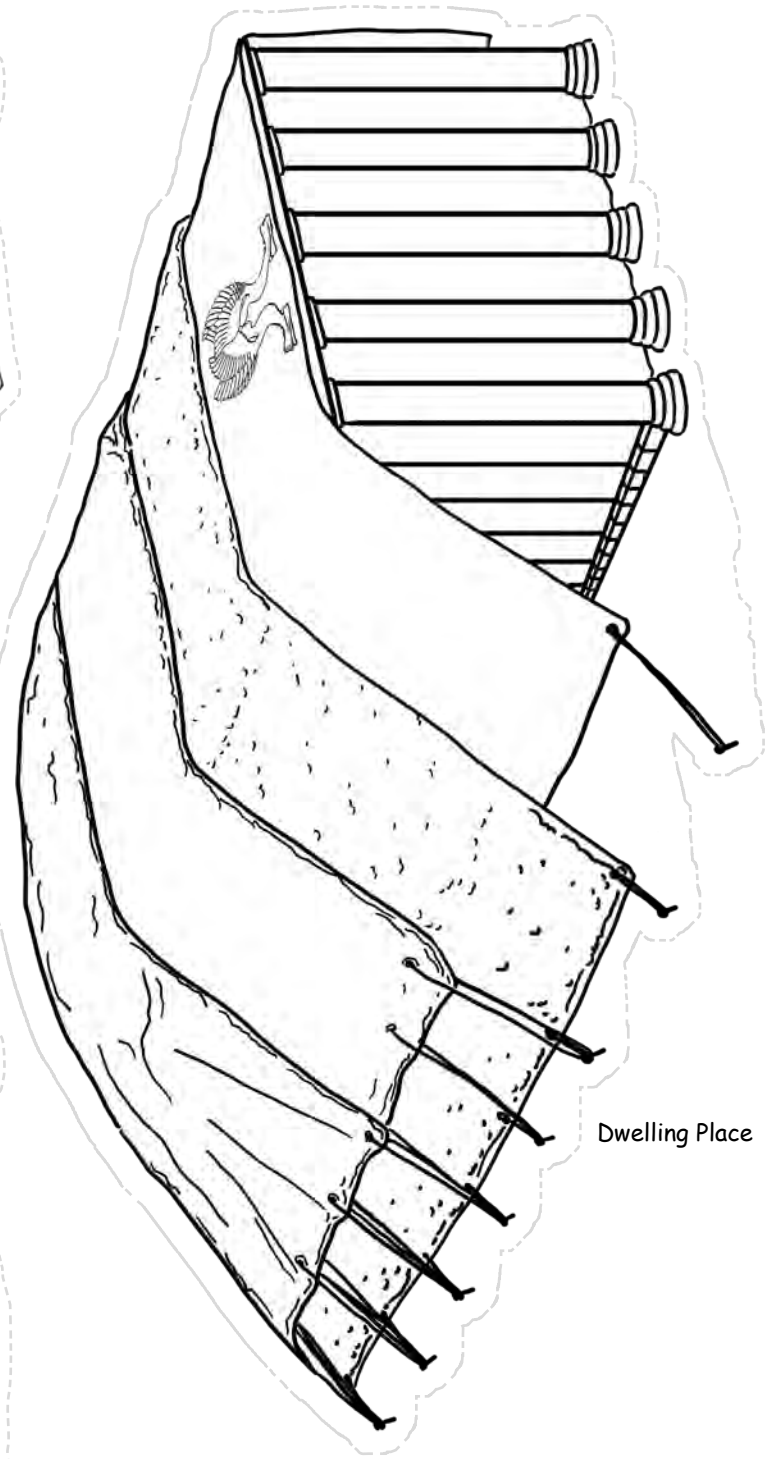

Dwelling Place

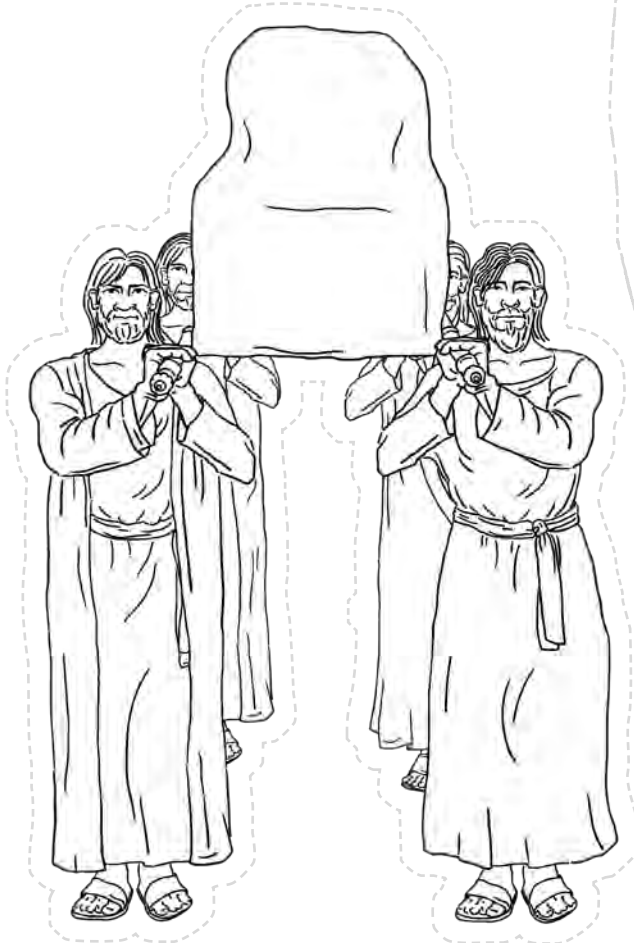

Group 4

Offerings scene

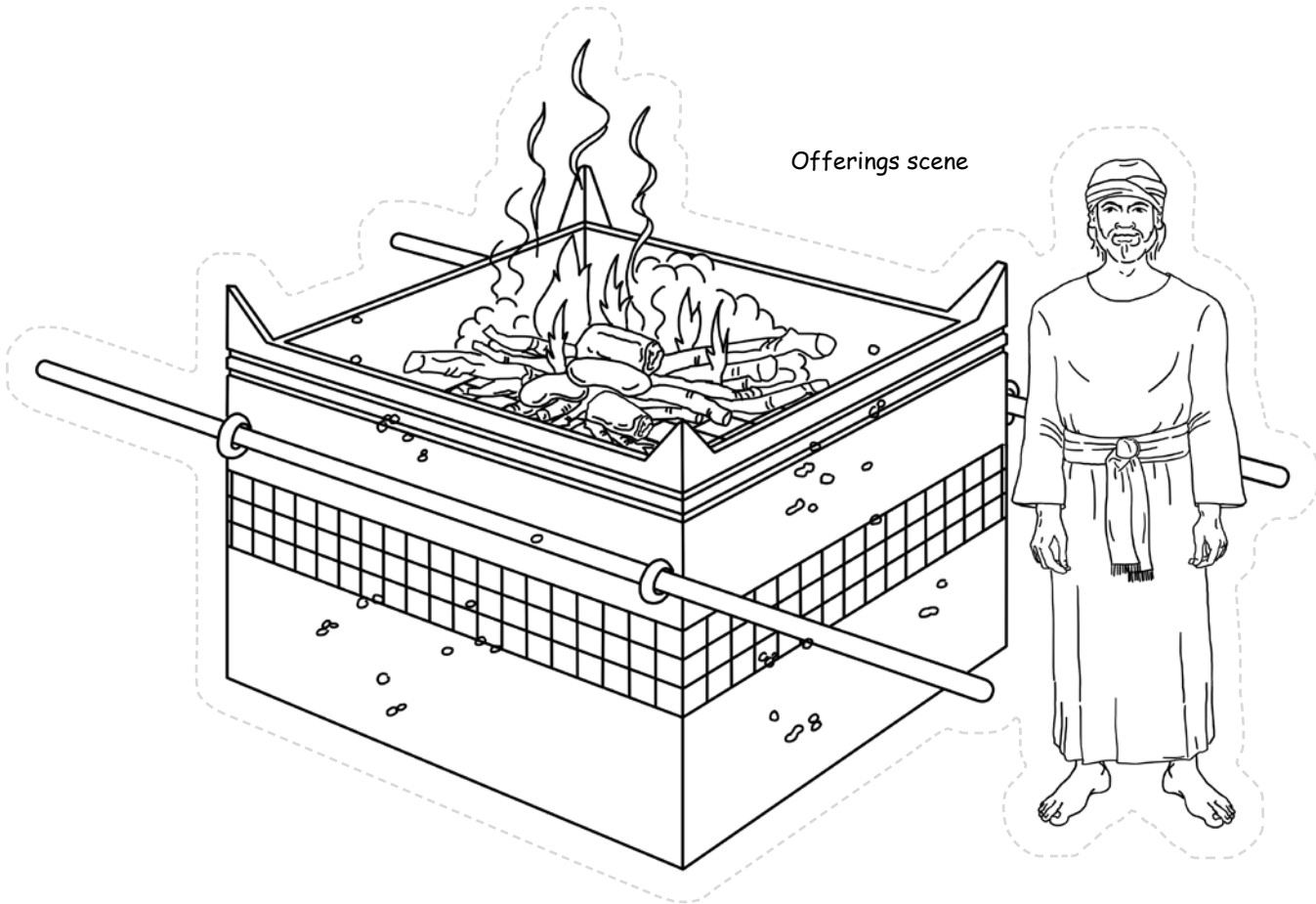

Yisra'elites

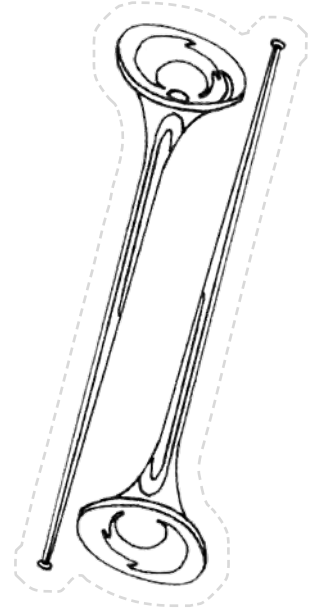
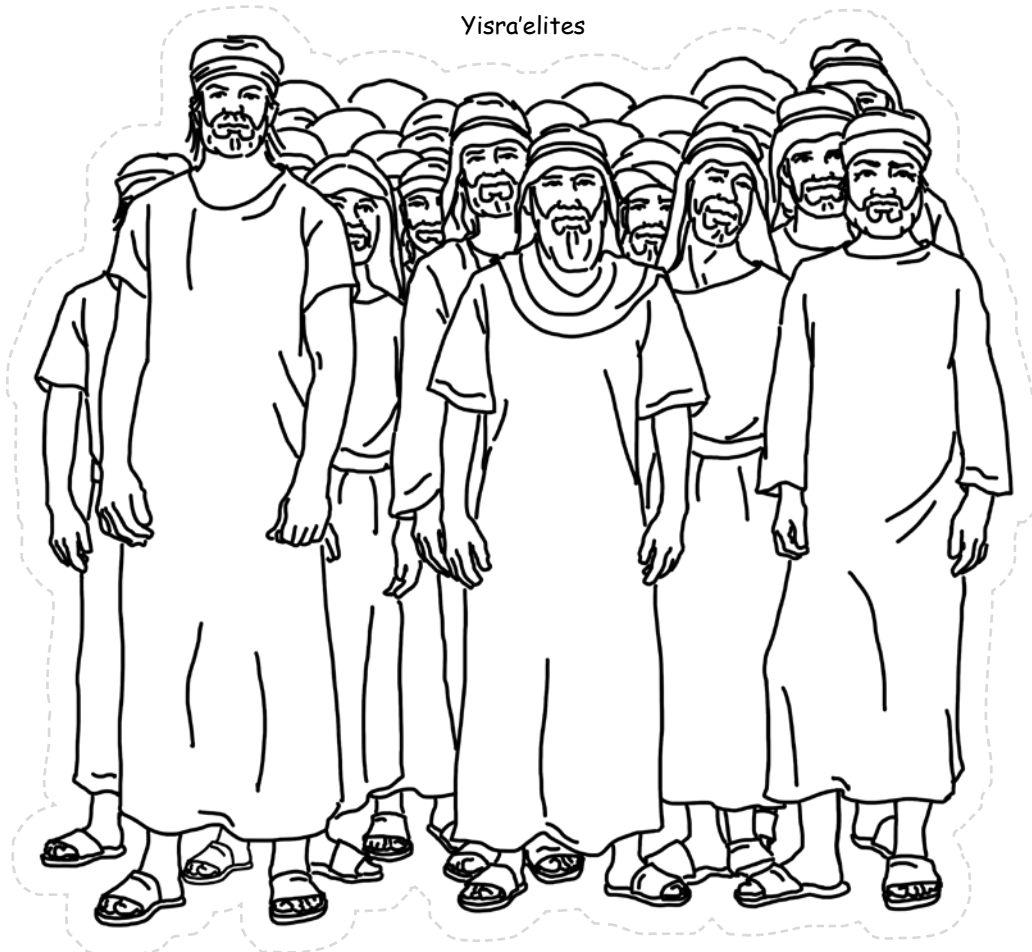

2 Silver trumpets

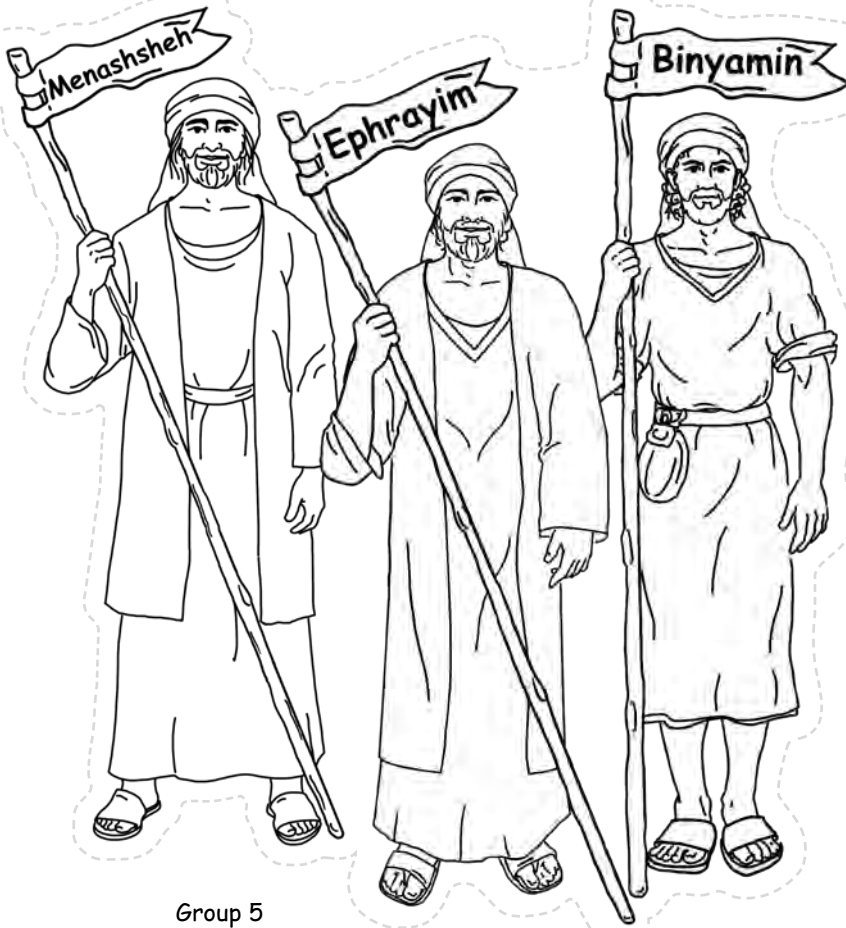

Group 5

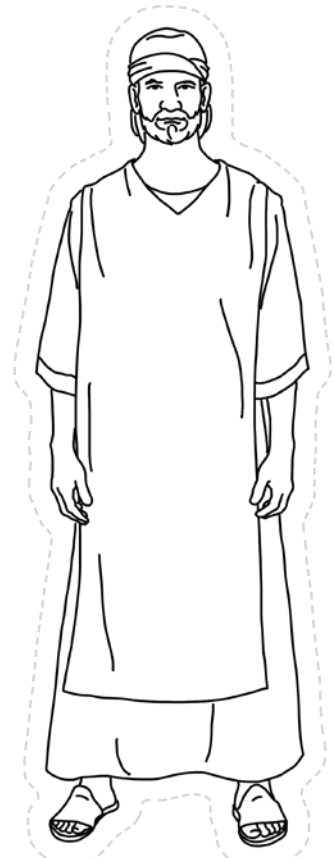

Hobab



Mosheh

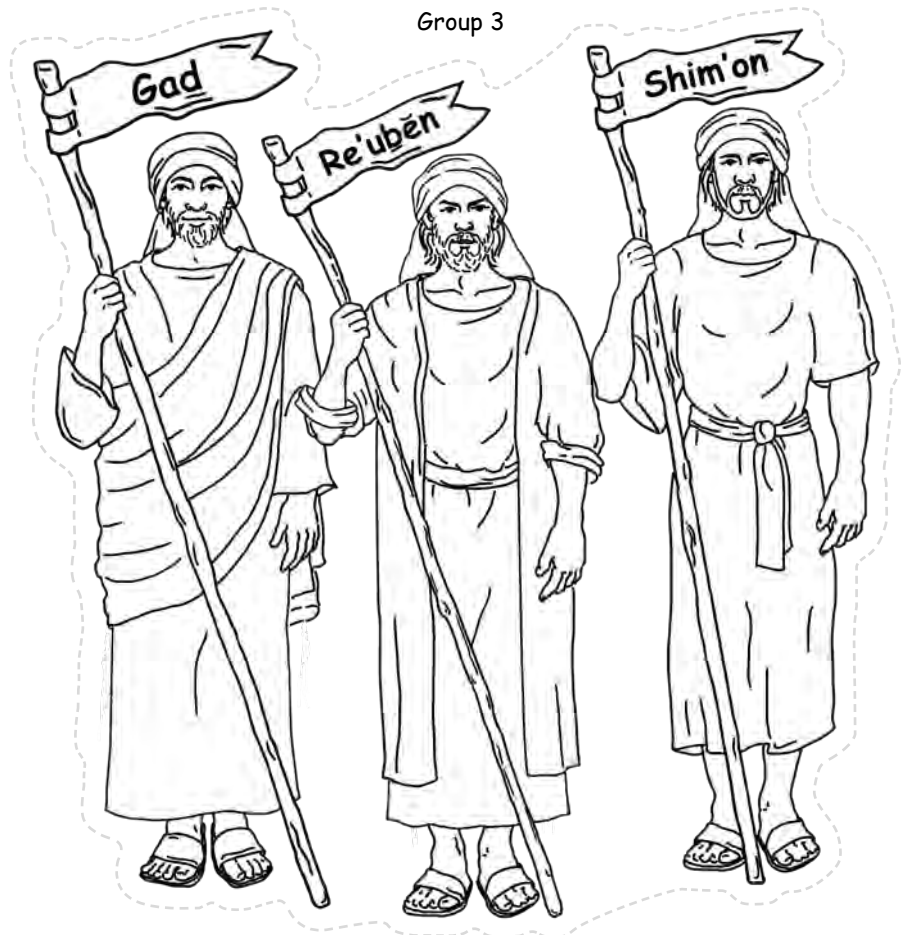

Group 3

Appointed
Times scene

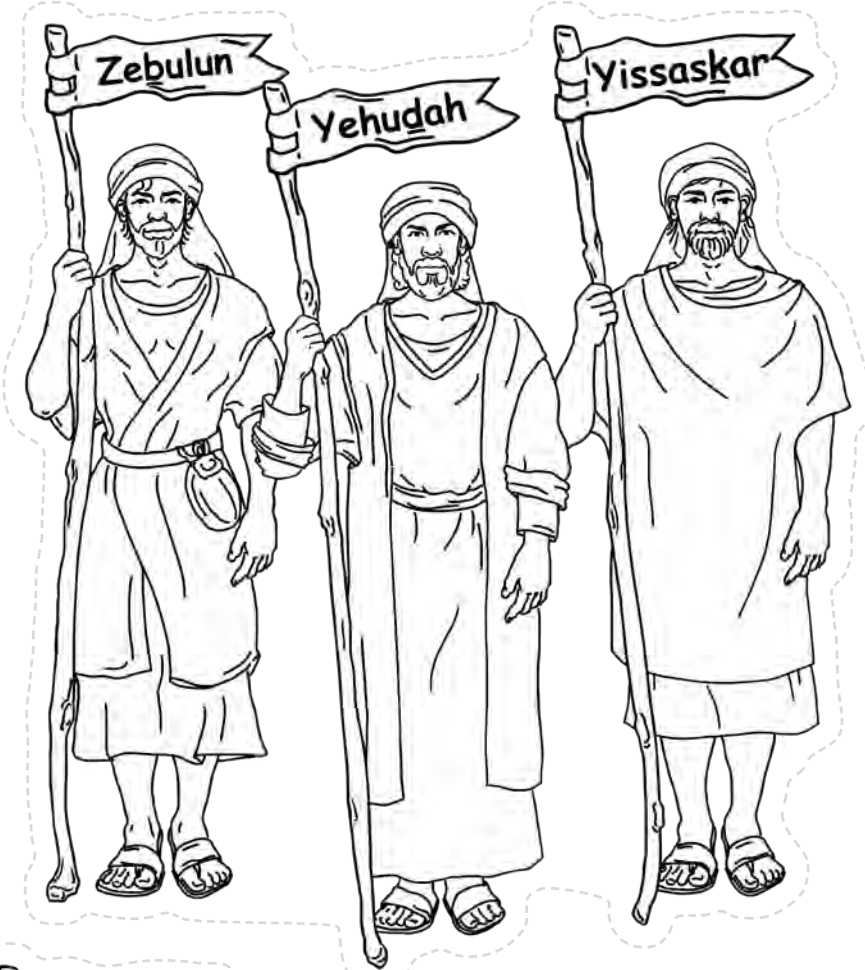
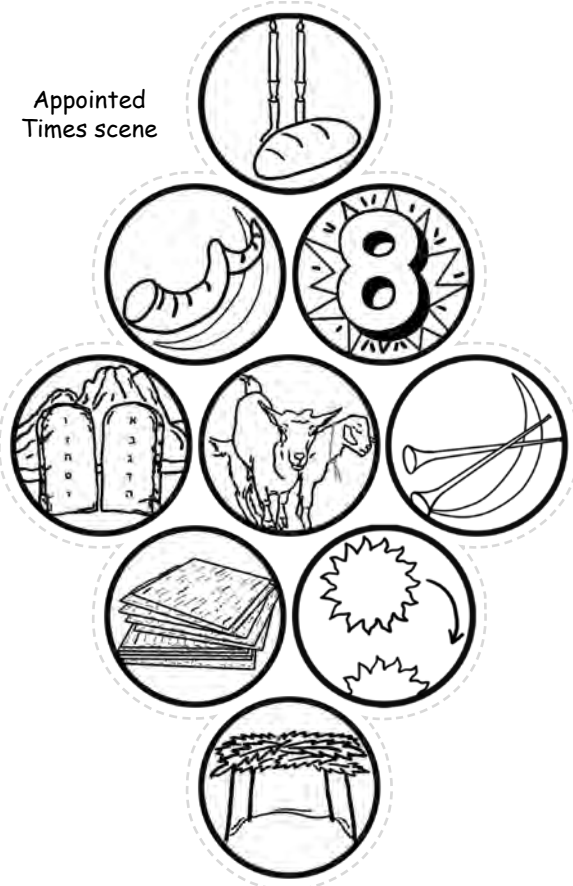

Group 1



Group 6



Counting What You Gained

This next section is intended to be reinforcement of the lessons learned during this parsha. Choose the activities that best fit your child.

STORING UP TREASURE IN MY HEART

The Katan Aleph memory verse for this Torah portion is Numbers 10:36. If they have not already done so, begin to help them to memorize the verse. Be creative and try acting it out, or putting it to music.

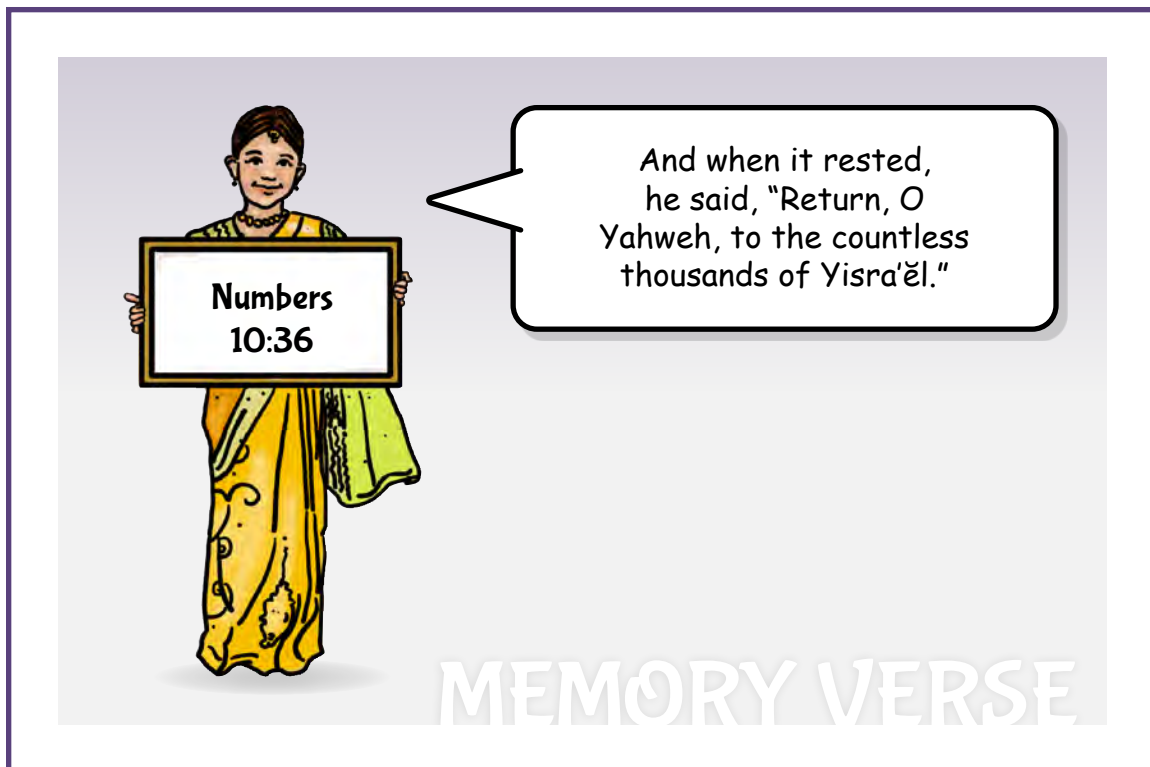

Use this space to draw a picture of the verse memorized.



Use this space to write out the verse memorized.



SEEKING TREASURE

Circle the correct choices.

1. What did the children of Yisra'el follow when it was time to break up camp? (9:17)



2. What sound was heard to gather the congregation and for breaking up camp? (10:2)



3. Who had the duty to blow the trumpets? (10:8)



Qehath's 4 sons



Ithamar & El'azar



Aharon



Mosheh

4. Which banner departed first according to their divisions? (10:14)



5. After the Dwelling Place was taken down, who departed second? (10:17)



Gershon's 2 sons

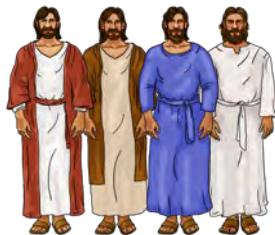

Qehath's 4 sons



Merari's 2 sons



Ithamar, Aharon & El'azar



6. Which banner departed third according to their divisions? (10:18)



7. Who departed fourth carrying the set-apart objects? (10:21)



Gershon's 2 sons

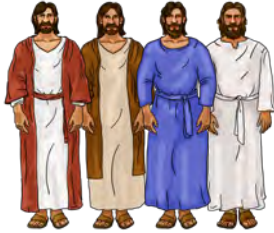

Qeath's 4 sons



Merari's 2 sons



Ithamar, Aharon & El'azar

8. Which banner departed fifth according to their divisions? (10:22)



9. Which banner departed sixth according to their divisions? (10:25)



10. Who did Mosheh want to help him in the wilderness as a scout? (10:29)



Hobab



Yehoshua



Yitro



Kaleb

WORD SEARCH

Search for the hidden words from this week's parsha.

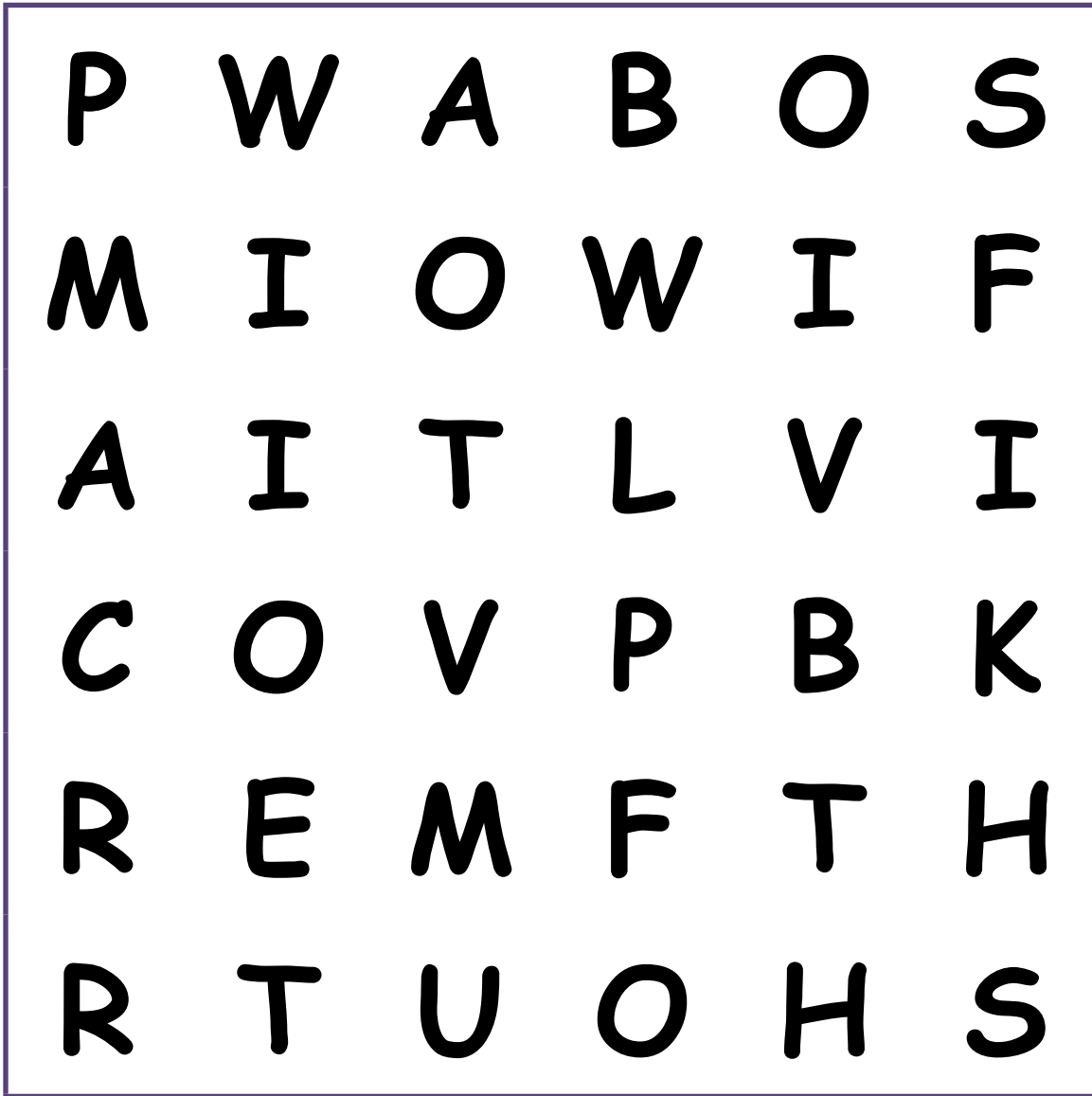

TWO
SILVER
BLOW
SHOUT
CAMP



MAZE

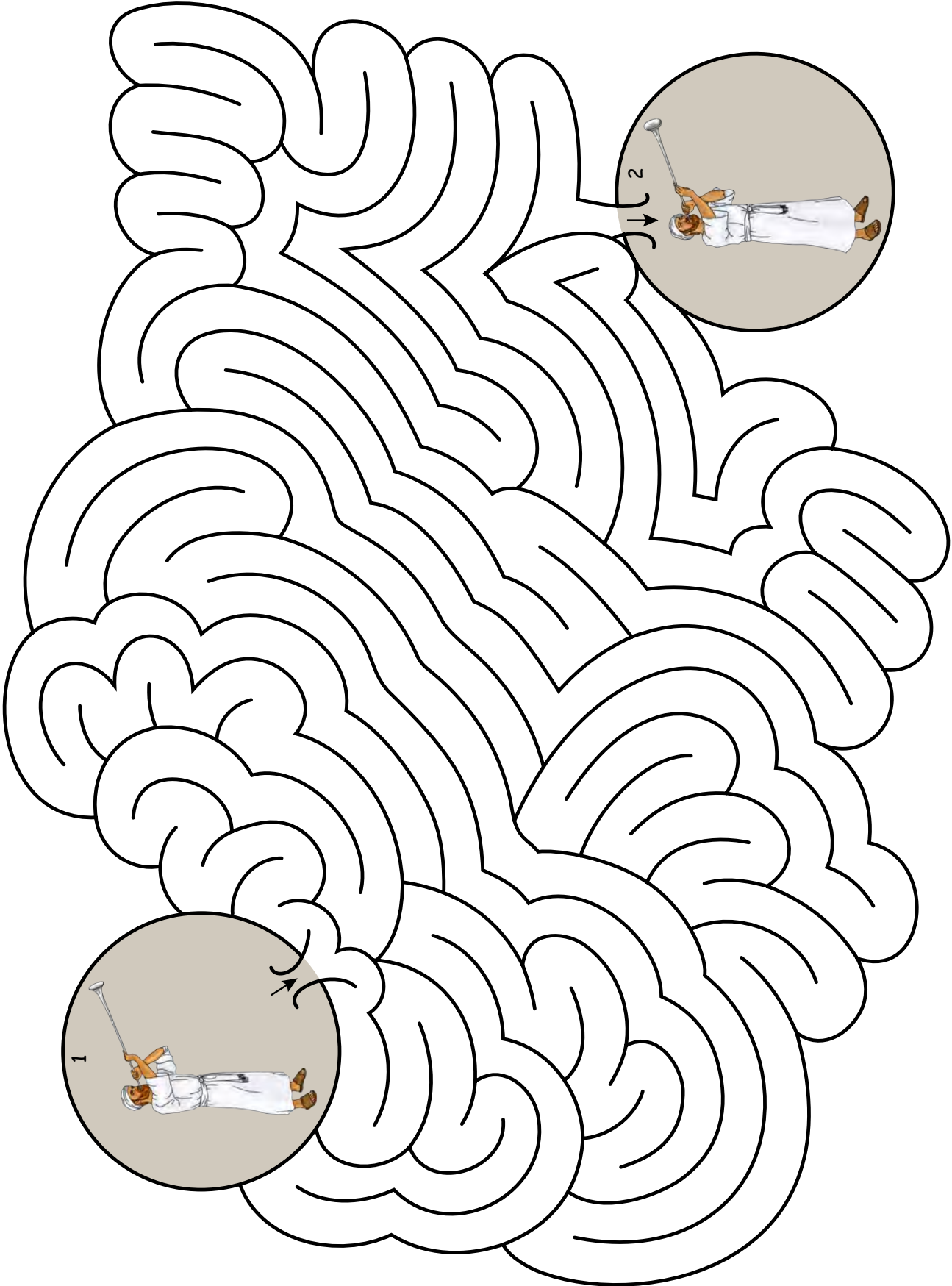

Precious Possessions

CRAFT

Silver Trumpet

Numbers 10:1-9

Materials:

- Long funnel
- Aluminum foil
- Party horn noise maker
- Scissors



Instructions for the Craft:

- Gather your materials: long funnel, aluminum foil and the plastic whistle from a party horn noise maker. (P1)
- Insert the plastic whistle into the narrow end of the funnel. (P2)
- Using aluminum foil, wrap it around the funnel starting at the whistle area, making sure to leave some of the whistle exposed. (P3)
- Keep wrapping the funnel to cover it completely on the outside above the whistle as well as inside the funnel. Cut off any excess length. (P4a, P4b, P4c)
- You can blow the trumpet on Yom HaTeruah (Day of Trumpets) festival.



P1



P2



P3



P4a

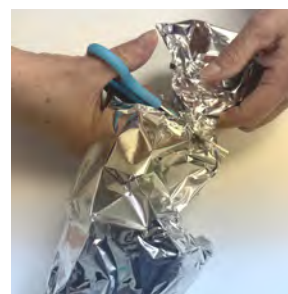

P4b



P4c

You now have visual representation of a trumpet that the priests used to gather the children of Yisra'el and for breaking camp.

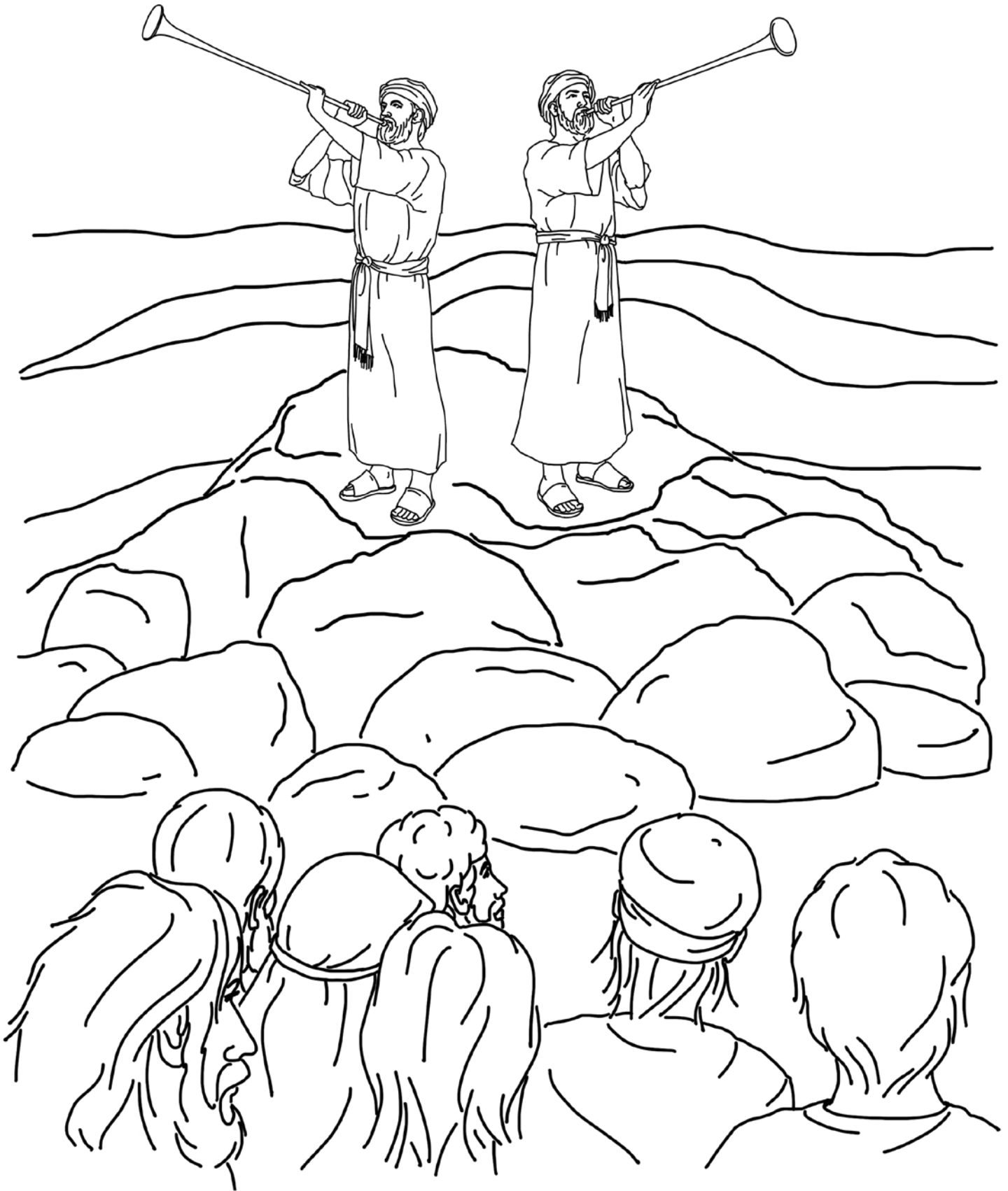

Sweetness of Torah

SWEET SOUNDS OF TORAH

(Sing Praises to His Name)

Here is the link for this song:

https://www.podomatic.com/podcasts/steveberkson/episodes/2017-06-04T15_12_50-07_00

Sing to tune of "I've Been Working on the Railroad"

I've Been Listening to the Trumpets

I've been listening to the trumpets, to the trumpet calls
I've been listening to the trumpets, so I'll know what to do

Yahweh asked for two silver trumpets, to gather the people around
Different blasts mean different things, listen for the sound:

Chorus:

Have the Kohein blow, have the Kohein blow
Have the Kohein blow the trumpets
Have the Kohein blow, have the Kohein blow
Have the Kohein blow the horn

One long blast means come together, two blasts quickly move on
Many short blasts means it's time for war, listen to the horn

(Repeat Chorus)

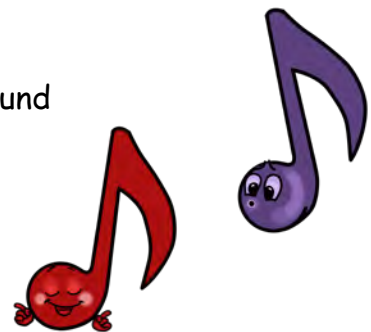

SWEET TASTE OF TORAH

This snack relates to this week's parsha. Please take these as suggestions and make necessary changes based on your individual dietary needs.

Banner Cookies

Numbers 10:14, 18, 22,25



Ingredients:

- Square or rectangle cookies that are store bought or homemade (represents banner)
- Pretzel sticks or rod (represents rod)
- Icing of your choice (to decorate banner)
- Sprinkles and/or candy decorations of your choice (to decorate banner)

Instructions:

Take a cookie and decorate it as a banner, any way you choose. You can also sign your name to have your own personalized banner.

Next Week's Treasure Hunt

Next Week's Torah Portion

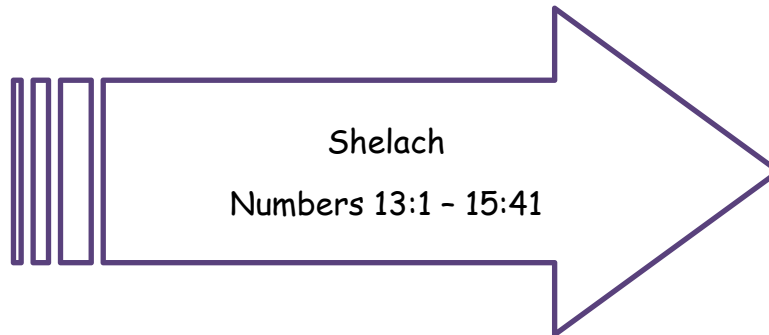

Suggested Reading Schedule

Monday:	Num. 13:1-25	One man from each of the 12 tribes sent to spy out the land of Kena'an
Tuesday:	Num. 13:26-33	The spies return with a report
Wednesday:	Num. 14	The children of Yisra'el rebel; Mosheh intercedes for the people; Yahweh relents, pronounces judgments
Thursday:	Num. 15:1-31	Instructions for various offerings and unintentional sins
Friday:	Num. 15:32-41	Penalty for violating Shabbat; Torah regarding tzitziyot