

Parsha Pearls

Ki Tavo

"When You Come In"

Deuteronomy 26:1 - 29:8

Katan Bet/Gadol



In This Edition:

50.1 - Becoming a Set-apart People
Deuteronomy 26



Table of Contents

Parsha Pearls is a comprehensive resource that allows for complete customization by the parent. We understand that if you were to strive to accomplish all aspects of each lesson in one day it would be unrealistic and also overload for the child. It is our intention that this be used 'a la carte' so that it suits your specific needs. Our site caters to printing only the pieces you choose.

This page will provide quick links to get to the portion of the document for which you are looking. When you hover over the title a finger will appear. Click on it and you will be taken directly to that page.

If you are new to Parsha Pearls, we have created an [Introduction](#) document outlining how to use our lessons, as well as a [Scriptural Inspiration](#) document, which explains our titles and the Scriptural inspiration for them. We pray that Parsha Pearls blesses your home and that your children will grow to love the Word and to never depart from keeping Torah. As always, feel free to email us at parshapearls@mtoi.org if you have any questions.

Pearl Seeking (The Main Lesson)	3
➤ Treasuring His Word (Overview of the Parsha)	3
➤ Parsha Points (Main Lesson Content)	3
➤ Digging Deeper (Thought Provoking Questions)	5
Searching Out Hebrew (Reading & Writing)	6
➤ Words	6
➤ Numbers	6
➤ Word Match	7
➤ Flashcards	8
➤ Writing Hebrew	9
Counting What You Gained (Worksheets)	10
➤ Storing Up Treasure In My Heart (Memory Verse)	10
➤ Seeking Treasure (Questions from the Parsha)	12
➤ Word Search	14
➤ Crossword Puzzle	16
➤ Maze	18
Precious Possessions (Arts & Crafts)	19
➤ Notebook Page	19
➤ Coloring Page	25
Sweetness of Torah	26
➤ Sweet Sounds of Torah (Song Corresponding to the Parsha)	26
➤ Sweet Taste of Torah (Snack Corresponding to the Parsha)	27
Next Week's Treasure Hunt (Looking Ahead to Next Week's Parsha)	28



Pearl Seeking

TREASURING HIS WORD

Let's do a quick overview of the entire Torah portion:

Monday:	Deut. 26:1-15	First-fruits and 3 rd tithe declaration and presentation to the priest
Tuesday:	Deut. 26:16-27:8	Covenant proclamations; Instructions for stone altar construction at Mt. Eybal, with Torah inscriptions
Wednesday:	Deut. 27:9-26	Curses spoken from Mt. Eybal for disobedience
Thursday:	Deut. 28:1-14	The blessings pronounced for obedience
Friday:	Deut. 28:15-29:8	Additional curses pronounced for disobedience; Preamble to renewal of the Sinaitic covenant

In this week's Parsha Pearls lesson, we will take a look at further instructions for the children of Yisra'el to follow when they enter the land. The focus is upon presenting their first-fruits and tithes at the place which Yahweh your Elohim chooses, and taking care of the Lewite, the stranger, the fatherless, and the widow within your gates. Yahweh then reiterates the Covenant He is making with Yisra'el to become a set-apart people. Now, let's read Deut. 26.

PARSHA POINTS

First-Fruits

- Take some of the first of all the fruits of the soil from your land that Yahweh your Elohim is giving you, and put it in a basket (**tene**) and go to the *place which Yahweh your Elohim chooses* to make His Name dwell there - 26:2
- You shall approach the priest and say, "I shall declare today to Yahweh your Elohim that I have come to the land which Yahweh swore to our fathers to give us" - 26:3
- The priest will take the basket from your hand and place it before the altar of Yahweh your Elohim - 26:4
- You shall answer and say before Yahweh your Elohim (26:5-10):
 - My father was a perishing Aramean, and he went down to Mitsrayim and sojourned there with few men, and there he became a nation, great, mighty, and numerous
 - The Mitsrites did evil to us, and afflicted us, and imposed hard labor on us
 - We cried out to Yahweh, Elohim of our fathers, and Yahweh heard our voice and saw our affliction and our toil and our oppression
 - Yahweh brought us out of Mitsrayim with a strong hand and with an outstretched arm, with great fear and with signs and wonders



- He brought us to this place and has given us this land, 'a land flowing with milk and honey'
- See, I have brought the first-fruits (**reshith p'ri**) of the land which You, O Yahweh have given me
- Then you shall place the first-fruits before Yahweh your Elohim, and bow down before Yahweh your Elohim - 26:10
- You shall rejoice in all the good which Yahweh your Elohim has given to you and your house, you and the Lewite and the stranger who is among you - 26:11

3rd Year Tithe

- When you have completed tithing all the tithe of your increase in the third year, and have given it to the Lewite, to the stranger, to the fatherless, and to the widow, and they have eaten *within your gates* and are satisfied, then you shall say before Yahweh your Elohim (26:12-15; 14:28-29):
 - I have put away the set-apart portion from my house, and also have given it to the Lewite, and to the stranger, and to the fatherless, and to the widow, according to all Your command which You have commanded me
 - I have NOT transgressed Your commands, nor have I forgotten
 - I have NOT eaten any of it when in mourning
 - I have NOT removed any of it for any unclean use
 - I have NOT given any of it for the dead
 - I have obeyed the voice of Yahweh my Elohim
 - I have done according to all that You have commanded me
 - Look from Your set-apart dwelling place, from the heavens, and bless Your people Yisra'el and the land which You have given us, as You swore to our fathers, 'a land flowing with milk and honey'



Covenanting with Yahweh

- Today, Yahweh your Elohim is commanding you to (26:16; 6:5; 10:12; 13:3):
 - do these laws and right-rulings
 - *guard* and do them with all your heart and with all your being
- You have, today, caused Yahweh to proclaim to (26:17):
 - be your Elohim
 - walk in His ways
 - *guard* His laws, His commands, His right-rulings
 - obey His voice
- Yahweh has caused you to proclaim today to (26:18; 7:6; 14:2):
 - be His people
 - be a treasured possession (**am segullah**), as He has spoken to you
 - *guard* all His commands
- Yahweh has set you high above all nations, which He has made, for a praise, and for a name, and for esteem, and for you to be a set-apart people (**am kadosh**) to Yahweh your Elohim, as He has spoken - 26:19; 7:6; Lev. 20:26



DIGGING DEEPER

Parents/Teachers may choose to use these prompts for further discussion of the Torah portion.

- Research what first-fruits are - the different kinds and their significance. When are they supposed to be brought to the priest? (Ex. 23:19, 34:26; Lev. 19:23-25)
- Chapter 26 contains precisely prescribed declarations which one must pronounce when presenting their first-fruits to the priest (26:5-10). Why do you think Yahweh required this?
- What does the phrase, "My father was a perishing Aramean" mean? Does it relay that Abraham our forefather was someone of no prestigious descent, occupation or location? Why do you think Yahweh wants them to always relate their entry into the land with 'remembering' where they came from?
- Discuss Yahweh's consideration of the Lewite, the stranger, the fatherless and the widow when He commands that they are to be taken care of at His feasts.
- Discuss the 3rd tithe, and the declaration one must make before Yahweh that they did not *steal or borrow* from it for any reason (26:13-14). Do you think it would be easy for a Yisra'elite to make this declaration falsely, fully aware that they were lying and would be held accountable? Do you think they could get away with it? Was there a way for the priest to know?
- The 3rd tithe is also known as the poor tithe, for it takes care of those in need. Since the poor are still among us, do you think that this tithe applies in our lives even though we are not in the land?
- If Yahweh calls us His treasured possession and has set us above the nations, how should we be walking in order to be worthy of that title?



Searching Out Hebrew

Parents/Teachers can print out the '[Hebrew Pronunciation Guide](#)' to help with the pronunciation of Hebrew names and words. They can be cut out and used in conjunction with the Flashcards.

WORDS

Parents/Teachers see the following page for 3 x 5 card cut outs of the words from this week's parsha. If printed on cardstock, they can be kept in a box to reinforce learning.

Tene (טנא) - basket

Reshith p'ri (ראשית פרי) - first-fruits (also called bikkurim)

Am segullah (סגולה עם) - treasured possession/treasured people

Am kadosh (קדש עם) - set-apart people

NUMBERS

Parents/Teachers can print out these numbers to have as additional resources. These can be found under the 'Resources' tab on the YMTOI website.

There are no numbers in this lesson

WORD MATCH

Match this week's Hebrew words to their correct definition.

Am Kadosh

Basket

Am Segullah

First-Fruits

Reshith P'ri

Set-apart people

Tene

Treasured Possession



FLASHCARDS

רֵאשִׁית פְּרִי

Reshith p'ri

Re-shith p-ri
first-fruits
(also called bikkurim)

עַם קָדוֹשׁ

Am kadosh

Am ka-dosh
set-apart people

טֵנָא

Tene

Te-ne
basket

עַם סְגוּלָה

Am segullah

Am se-gul-lah
treasured possession/treasured
people

WRITING HEBREW

Reshith p'ri (first-fruits)

ראשית פרי

Yud Resh Fey Tav Yud Shin Aleph Resh
 י ר פ ת י ו ש א ר

Tene (basket)

טנא

Aleph Nun Tet
 א נ ט

Am kadosh (set-apart people)

עם קדוש

Shin Dalet Qof Mem Soft Ayin
 ש ד ק מ ע

Am segullah
 (treasured possession/treasured people)

עם סגולה

Hey Lamed Vav Gimmel Samech Mem Soft Ayin
 ה ל ו ג ס מ ע



Counting What You Gained

This next section is intended to be reinforcement of the lessons learned during this parsha. Choose the activities that best fit your child.

STORING UP TREASURE IN MY HEART

The Katan Bet and Gadol memory verse is Deuteronomy 26:16. You can review the verse with them by reciting it out loud, acting it out, putting it to music...whatever works for you.

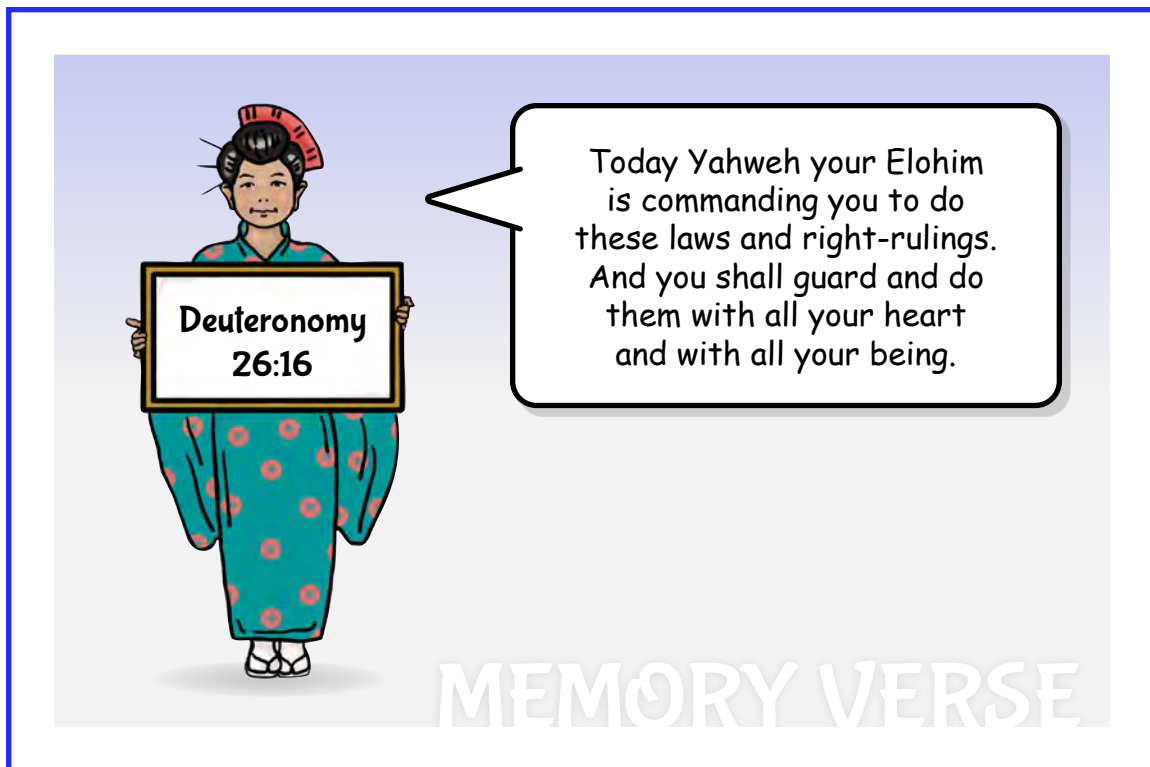

Deuteronomy
26:16

Today Yahweh your Elohim
is commanding you to do
these laws and right-rulings.
And you shall guard and do
them with all your heart
and with all your being.

MEMORY VERSE

Use this space to draw a picture of the verse memorized.

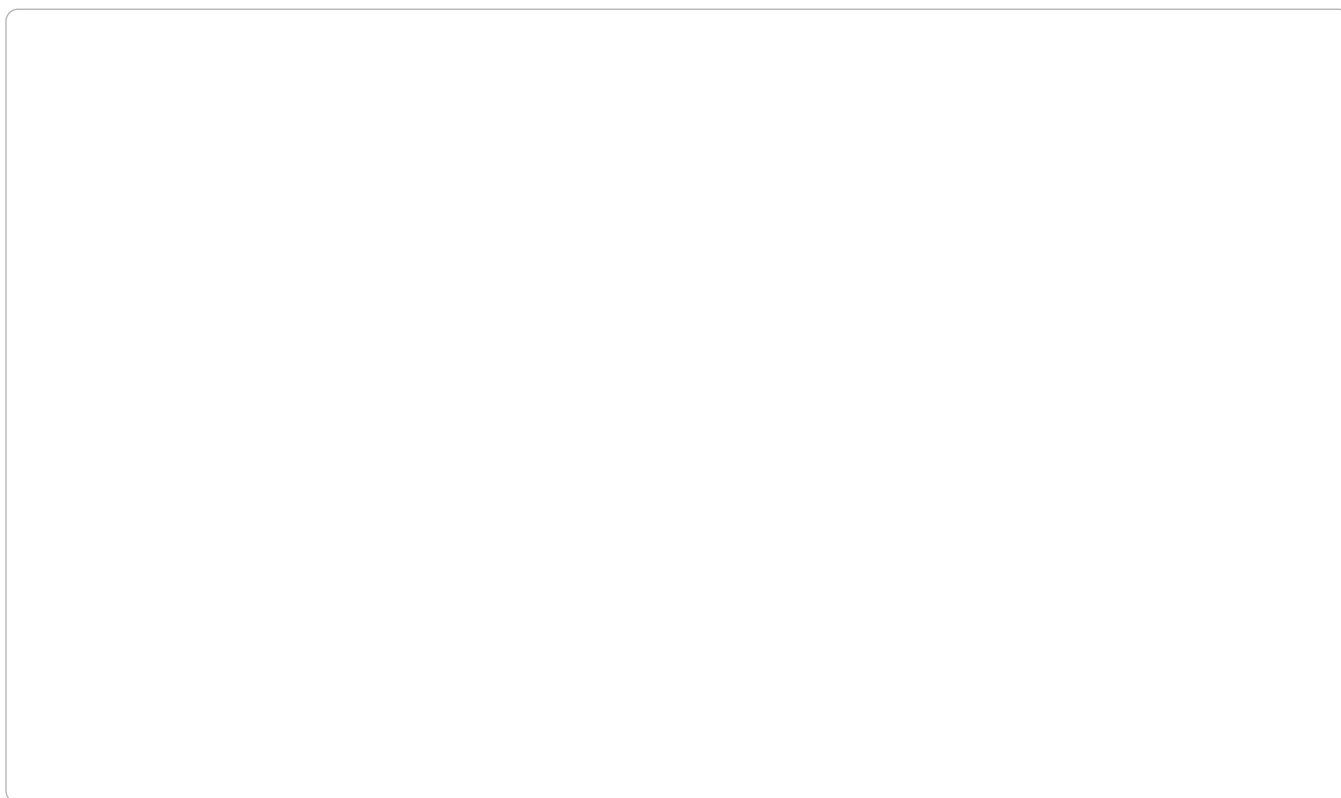

Use this space to write out the verse memorized.



SEEKING TREASURE



1.

When people prepared to bring their first-fruits to the priest, what kind of container were they told to place it in?

Circle the correct choice.

- | | | |
|----------|---------|--------|
| backpack | purse | basket |
| barrel | plastic | tote |

(26:2, 4)



2.

"And Yahweh brought us out of Mitsrayim with a strong _____ and with an outstretched _____, with great _____ and with _____ and _____."

(26:8)

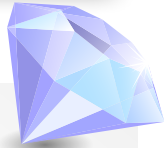

3.

Yahweh brought them to a land flowing with gold and silver.

T / F

(26:9, 15)

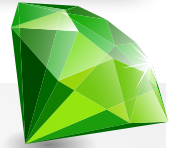

4.

What action were the people supposed to do once they brought the first-fruits to the priest and placed it before Yahweh?

Circle the correct choice.

- curtsey high five bow down

(26:10)

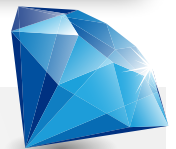

5.

Who is the 3rd tithe for?

(26:12-13)



6.



We are allowed to eat the tithe
if we are mourning (sad).

T / F

(26:14)

7.



According to 26:16-17, what actions are
we to take regarding Elohim's laws, right-
rulings, commands and His voice?

Circle the correct choices.

do guard walk obey

8.

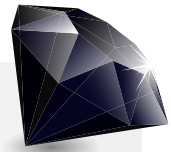

What does Yahweh call those who do, guard, walk in His ways, and obey?

Circle the correct choices.

His people a treasured possession Set-apart

(26:18-19)



WORD SEARCH

Search for the hidden words from this week's parsha.

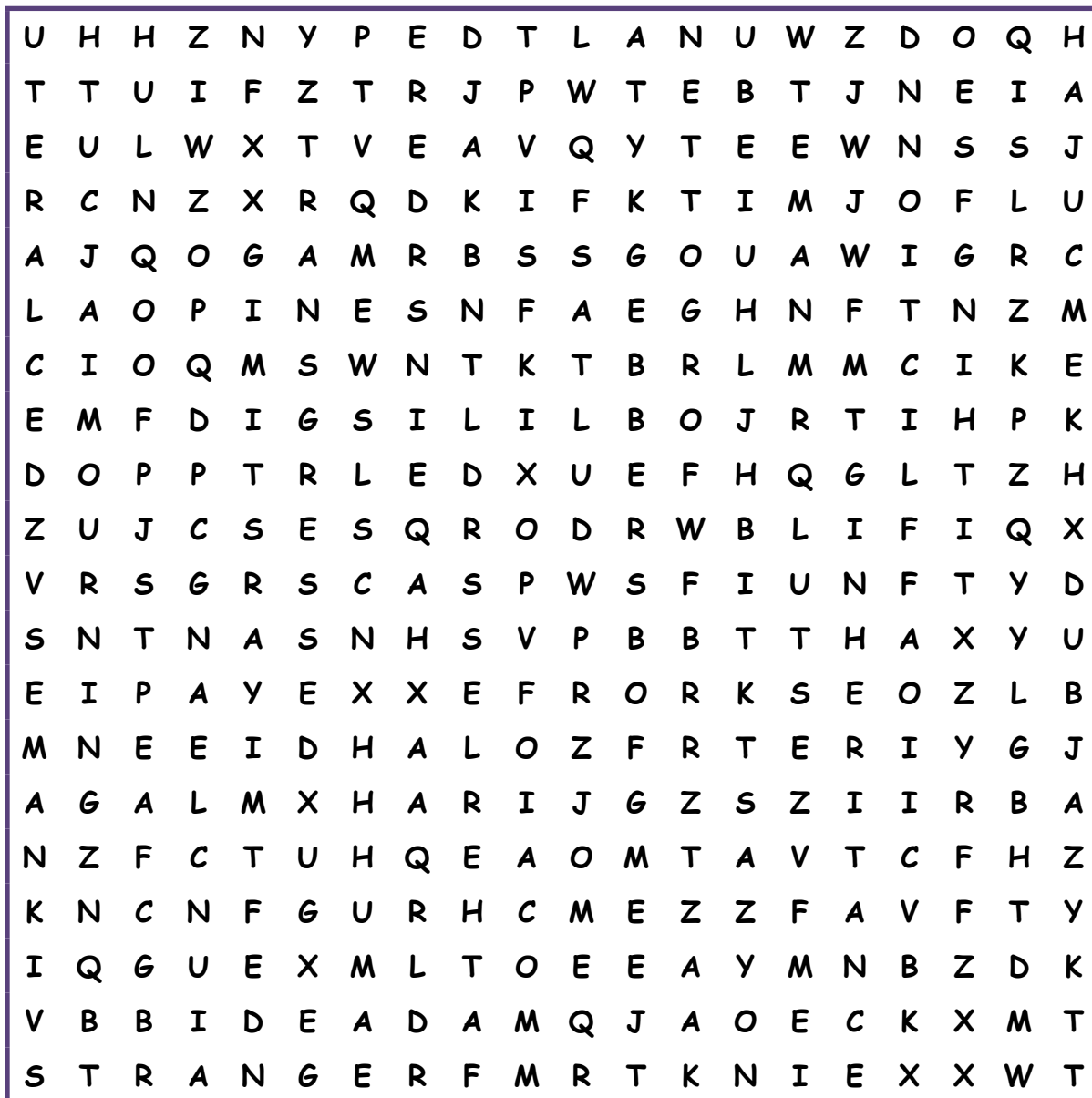

INHERITANCE
FIRST-FRUITS
BASKET
DECLARE
ARAMEAN
MITSRAYIM
AFFLICTION

OPPRESSION
TITHING
LEWITE
STRANGER
FATHERLESS
WIDOW
TRANSGRESSED

FORGOTTEN
MOURNING
UNCLEAN
DEAD
PRAISE
NAME
ESTEEM



Answer Key

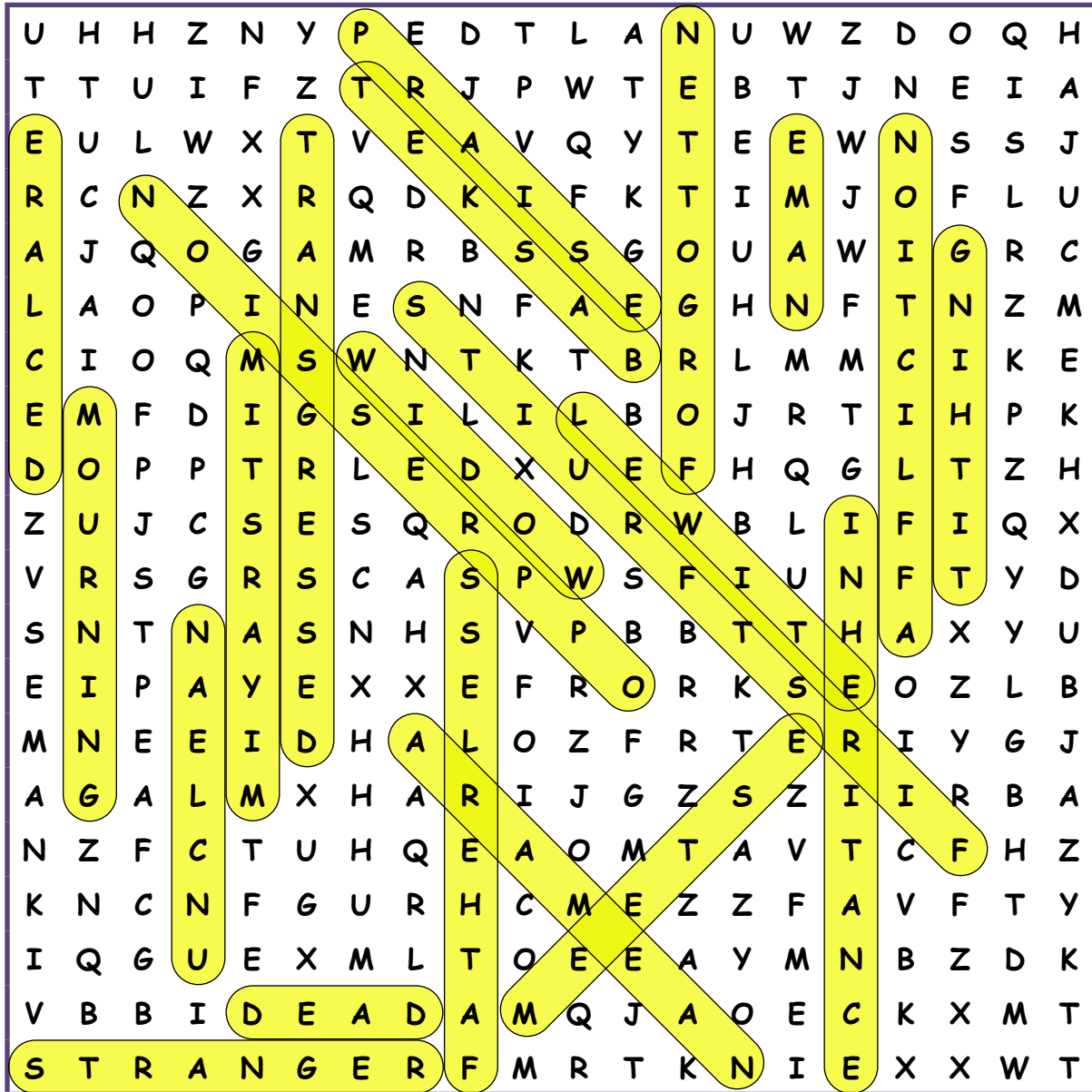

INHERITANCE
 FIRST-FRUITS
 BASKET
 DECLARE
 ARAMEAN
 MITSRAYIM
 AFFLICTION

OPPRESSION
 TITHING
 LEWITE
 STRANGER
 FATHERLESS
 WIDOW
 TRANSGRESSED

FORGOTTEN
 MOURNING
 UNCLEAN
 DEAD
 PRAISE
 NAME
 ESTEEM



CROSSWORD PUZZLE

Complete the crossword using words from this week's parsha.

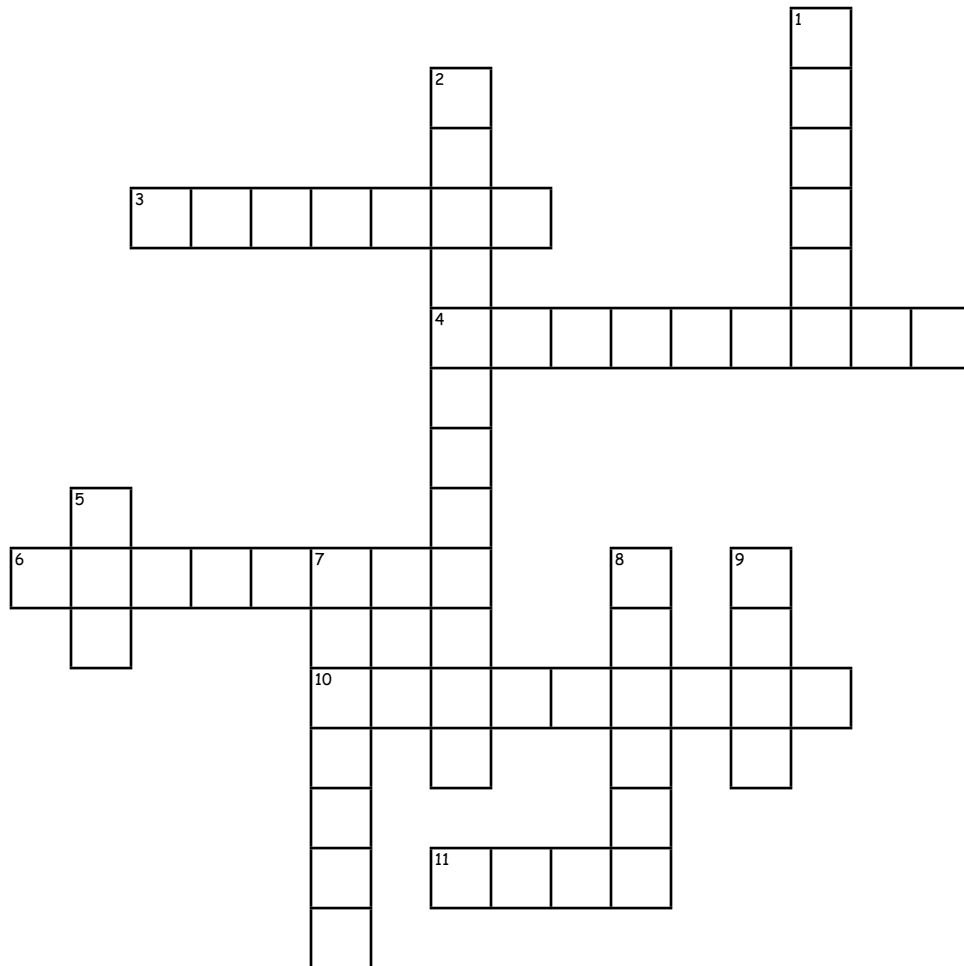

Across

3. I have not removed any of it for any _____ use.
4. The priest shall take the basket and place it near the _____ place of Yahweh Elohim.
6. Guard His laws, and His _____, and His right-rulings.
10. You are a _____ possession.
11. Walk in all His _____.

Down

1. You shall put your first-fruits in a _____.
2. I have not _____ Your commands, nor have I forgotten.
5. After the offeror presents the first-fruits, he is to _____ down before Yahweh Elohim.
7. He will set you high above all _____ which He has made.
8. When you come into the land you shall take some of first of all the _____ of the soil to the priest.
9. _____ His voice.



Answer Key

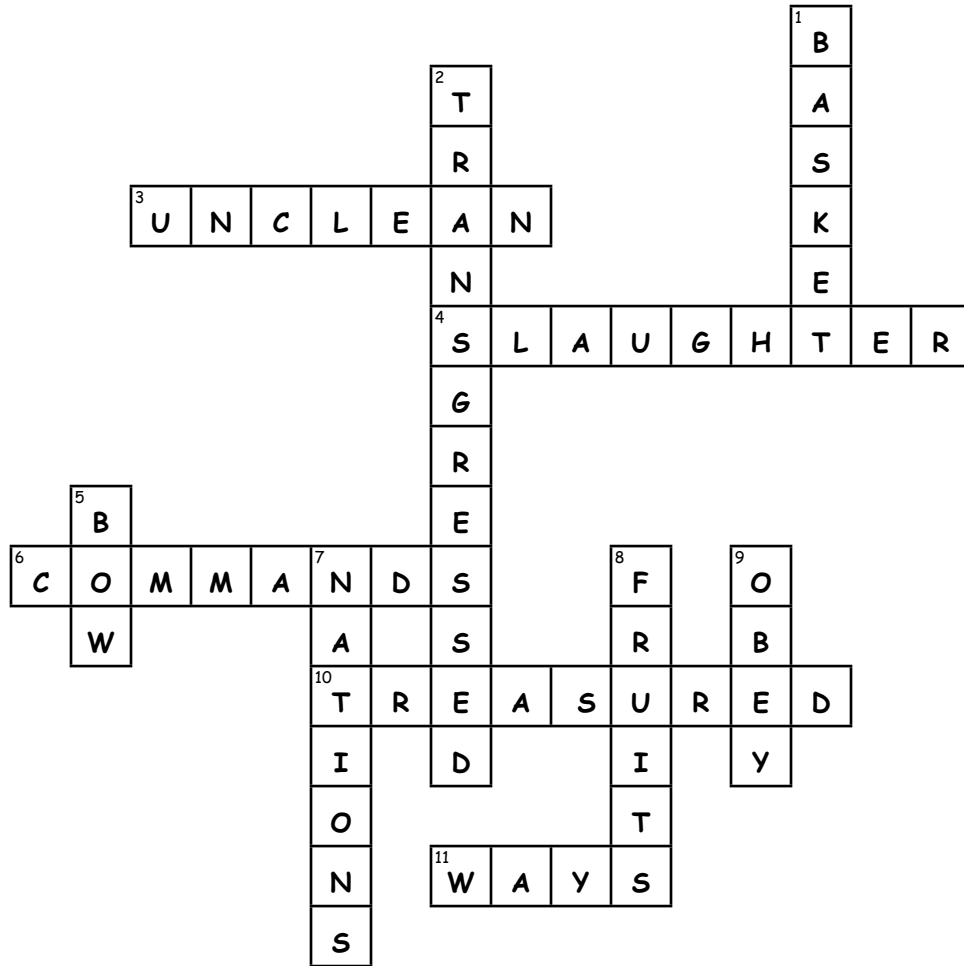

Across

3. I have not removed any of it for any **unclean** use.
4. The priest shall take the basket and place it near the **slaughter** place of Yahweh Elohim.
6. Guard His laws, and His **commands**, and His right-rulings.
10. You are a **treasured** possession.
11. Walk in all His **ways**.

Down

1. You shall put your first-fruits in a **basket**.
2. I have not **transgressed** Your commands, nor have I forgotten.
5. After the offeror presents the first-fruits, he is to **bow** down before Yahweh Elohim.
7. He will set you high above all **nations** which He has made.
8. When you come into the land you shall take some of first of all the **fruits** of the soil to the priest.
9. **Obey** His voice.



MAZE

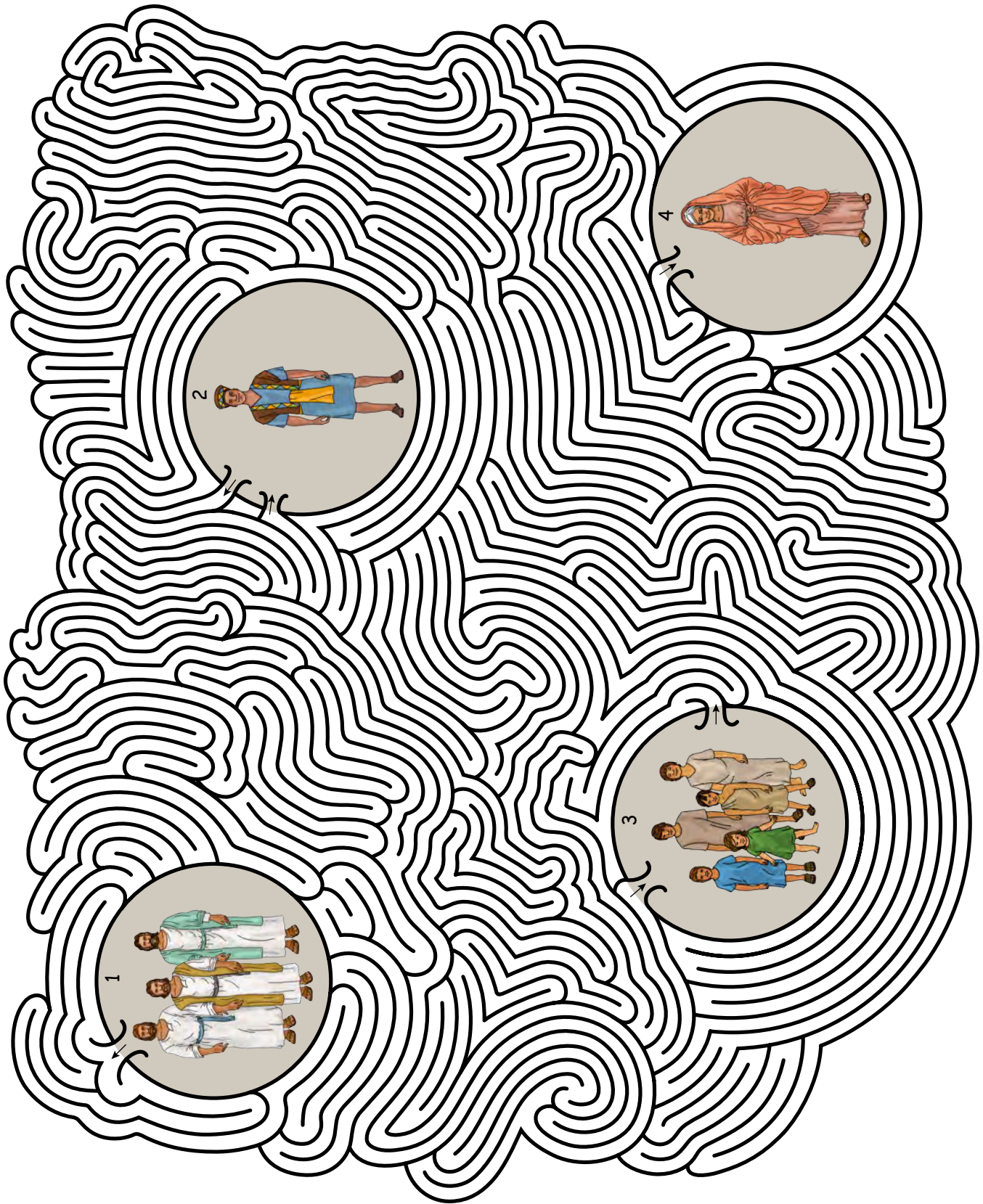

Precious Possessions

NOTEBOOK PAGE

First-Fruits

Deuteronomy 26:1-3, 10

Materials:

- Cardstock - white
- Wheat seeds or seeds of choice (to add dimension to the basket and wheat stalks)
- Puncturing tool
- Tiny brad
- Ruler - to assist in folding tabs
- Double-sided tape
- Glue
- Scissors
- Coloring pencils, crayons, or markers
- Notebook Page Templates: Main Page & A (BW) or Main Page & B (color)



Parent/Teacher Preparation:

- Print Notebook Page Templates of choice on white cardstock.

Instructions for the Notebook Page:

- If using BW Templates, color using medium of choice.
- Cut out all Notebook Templates. (P1)
- Using a puncturing tool, make a hole through the dots on the offeror's shoulder with basket piece and shoulder on body. (P2a, P2b)
- Insert a brad through the 2 parts making sure to have the shoulder with basket under the offeror. (P3)
- Spread glue on the offeror's basket and the wheat stalks. (P4a, P4b)



P1



P2a



P2b



P3



P4a

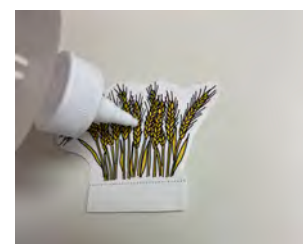

P4b

Instructions for the Notebook Page Cont'd:

- Place wheat or seeds of choice on the glue to add dimension to the basket and wheat stalks. (P5)
- Allow to dry, then using a ruler to assist you, fold the tabs inward on the images. (P6a, P6b)

Adding the Characters to the Main Page

- Run double-sided tape onto the tabs of the images and start adding to the Main Page as follows: (P7)
 - House scene at the top of the map (P8a)
 - Courtyard East gate on the middle of the map near the word Yerushalayim (P8b)
 - Priest in front of the gate (P8c)
 - Offeror with basket to the left and slightly in front of the priest (P8d)
 - Wheat stalks (P8e)
- Your page is now ready for the Hebrew Words. (P9)

Hebrew Words

- Write the following directly onto the Main Page or a piece of colored cardstock and glue to the page:
 - 1) Tene 2) טנא 3) Basket (P10)
 - 1) Reshith P'ri 2) ראשית פרי 3) First-Fruits (P11)

You now have a visual representation of the command to bring the first-fruits to the priest at the place where Yahweh Elohim puts His Name.



P5



P6a

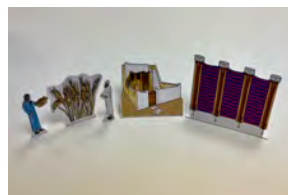

P6b



P7

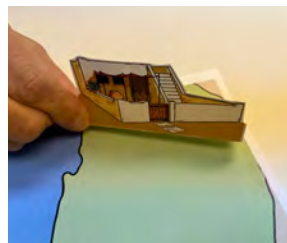

P8a

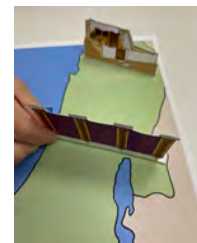

P8b



P8c



P8d

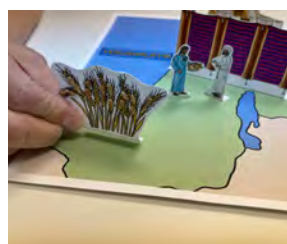

P8e



P9



P10



P11

An outline map of the state of Israel, showing its irregular borders. A rectangular box is drawn on the left side of the map, containing the Hebrew word for Jerusalem. The map is a simple black line drawing on a white background.

YERUSHALAYIM

Notebook Template A (BW)

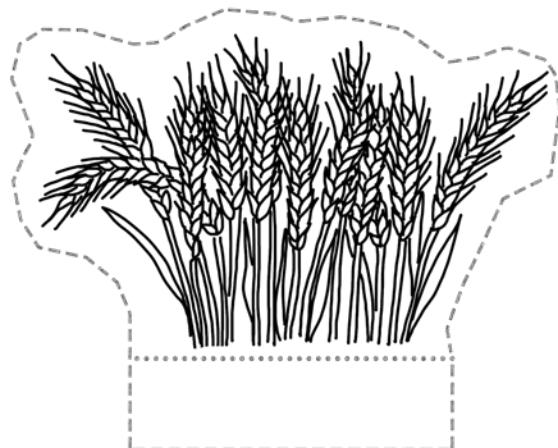
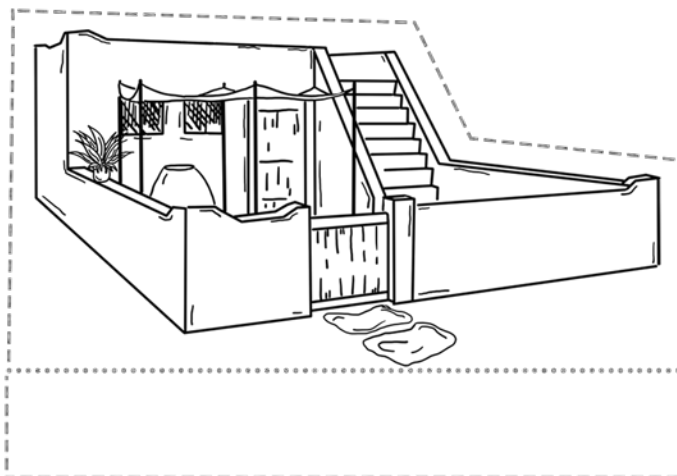
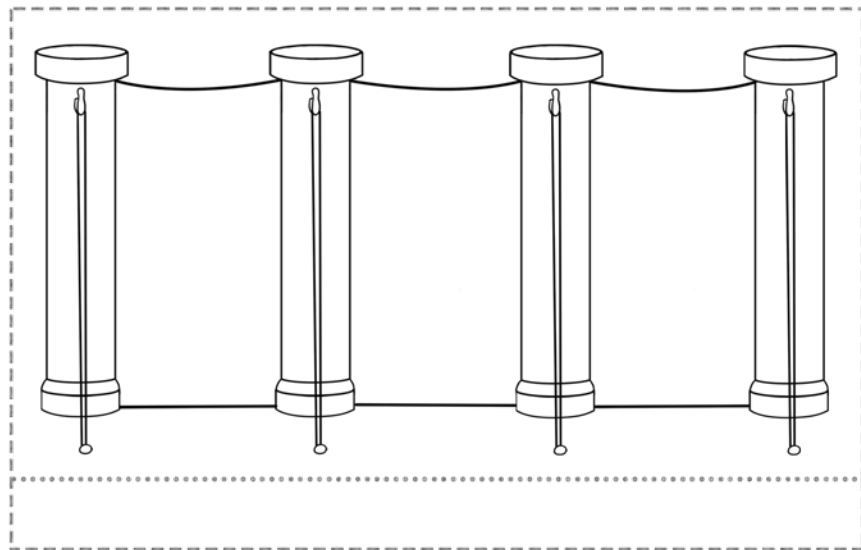
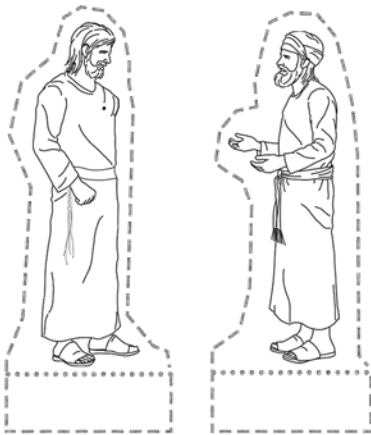



YERUSHALAYIM

Notebook Template B (color)

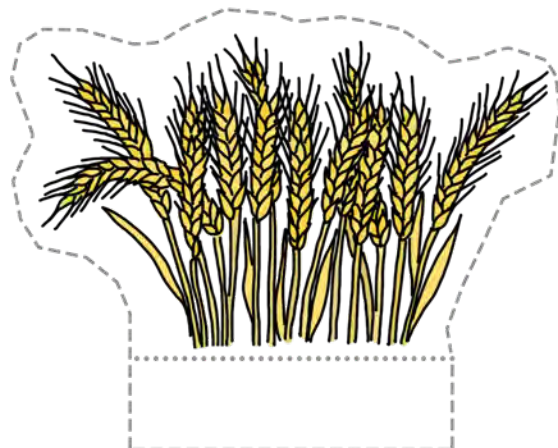
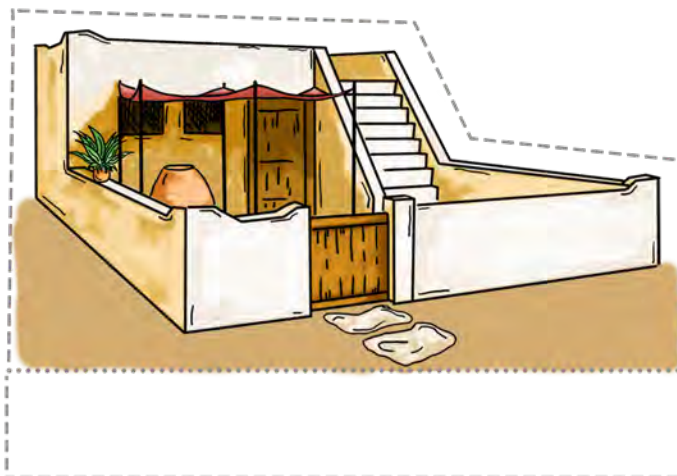
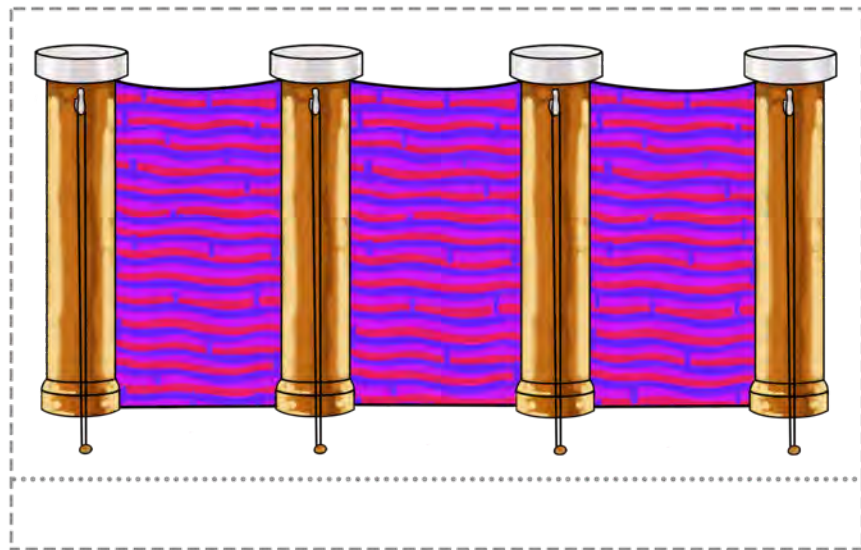
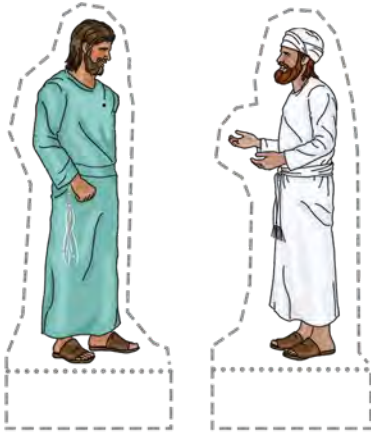

"And now, see, I have brought the first-fruits of the land which You, O Yahweh, have given me.' Then you shall place it before Yahweh your Elohim, and bow down before Yahweh your Elohim, and rejoice in all the good which Yahweh your Elohim has given to you and your house, you and the Lēwite and the stranger who is among you." - Deuteronomy 26:10-11

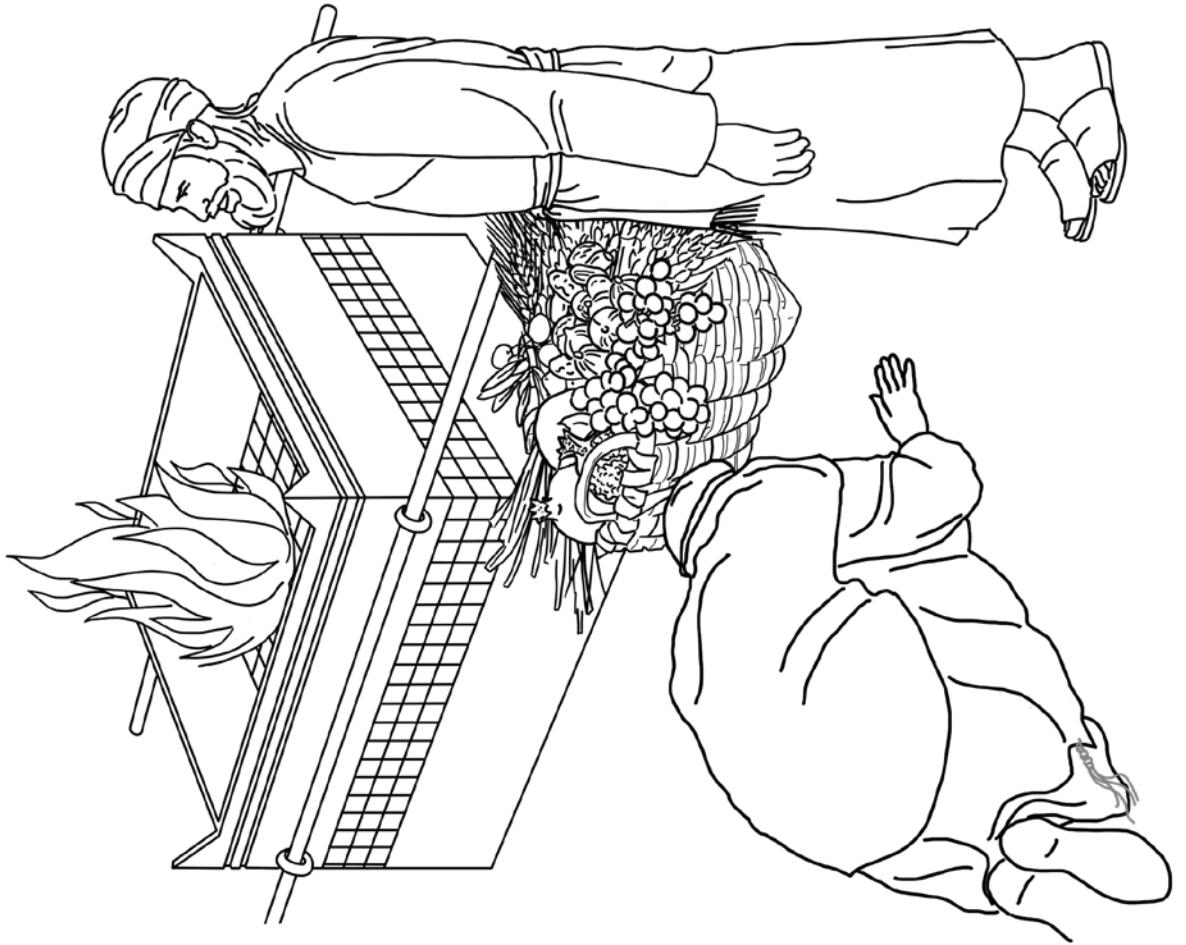

"When you have completed tithing all the title of your increase in the third year... then you shall say before Yahweh your Elohim, 'I have put away the set-apart portion from my house, and also have given it to the Lēwite, and to the stranger, and to the fatherless, and to the widow, according to all Your command which You have commanded me. I have not transgressed Your commands, nor have I forgotten...' - Deuteronomy 26:12-13

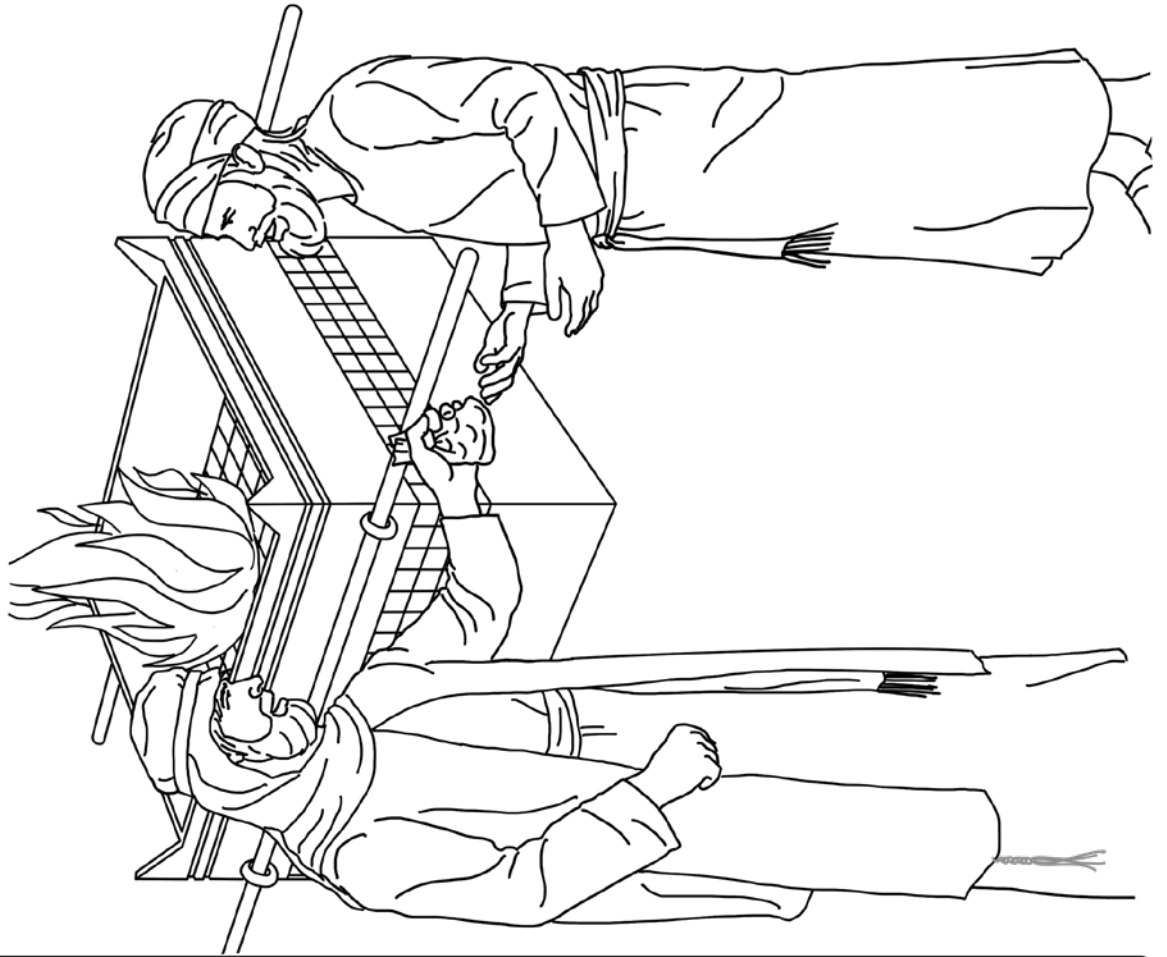

Sweetness of Torah

SWEET SOUNDS OF TORAH

(Sing Praises to His Name)

Here is the link for this song:

https://www.podomatic.com/podcasts/steveberkson/episodes/2017-09-03T07_23_03-07_00

Hayom Hazeh

When you come to Erets Yisra'el after working in your field
A special mitzvah is required of the first-fruits it does yield
Bikkurim reminds us that our toil was a success
All our work and our first-fruits by Yahweh were blessed

In the empty, lonely desert many mitzvot were explained
We accepted them all by answering amen
Hayom hazeh nihyesa le'am, a nation to Yahweh we did become
To the Torah we are true, we're the chosen few

These merits of the past have always helped us through
Each day is hayom hazeh by doing mitzvot that we know
Hayom hazeh nihyesa le'am, a nation to Yahweh we did become
To the Torah we are true, we're the chosen few



Erets Yisra'el - land of Israel

Mitzvah - command (often referred to as good deed)

Bikkurim - first-fruits

Mitzvot - commandments

Hayom hazeh nihyesa le'am - "This day you have become the people of Yahweh your Elohim" (Deut. 27:9)

SWEET TASTE OF TORAH

This snack relates to this week's parsha. Please take these as suggestions and make necessary changes based on your individual dietary needs.

Basket for First-Fruits

Deuteronomy 26:2, 4

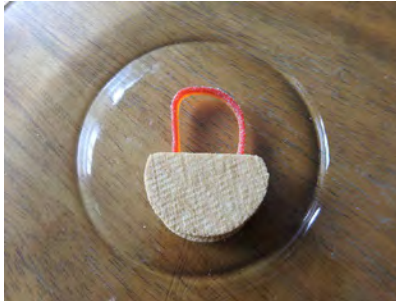

Ingredients:

- Vanilla stuffed cookies (represents basket)
- Rope or string candy (represents handles on basket)

Instructions:

Cut the cookies in half. Cut rope or string candy to desired length. Attach the rope or string candy handles by inserting into vanilla cream.

You now have a visual of the basket that one was required to bring to the priest of the first-fruits.

Next Week's Treasure Hunt

Next Week's Torah Portion

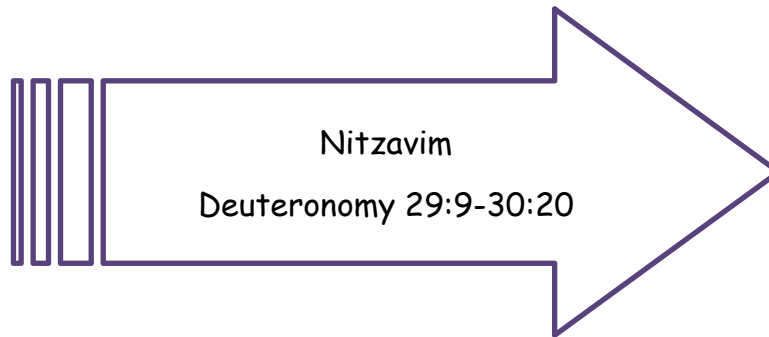

Suggested Reading Schedule

Monday:	Deut. 29:9-21	Terms of the Covenant
Tuesday:	Deut. 29:22-29	Exhortation to guard the Covenant in order to receive the blessings and avoid the curses
Wednesday:	Deut. 30:1-10	Exhortation to return to Yahweh in order to receive the blessings and reverse any judgments
Thursday:	Deut. 30:11-16	Repentance and forgiveness
Friday:	Deut. 30:17-20	Exhortation that Yahweh's Commandments are not too difficult; therefore choose Life