

Yom Teruah

"Yom Teruah Edition"
(Day of Trumpets)

Leviticus 23:23-25; Numbers 28:1-8, 11-15; Numbers 29:1-6
Katan Aleph



Special Feast Edition

INTRODUCTION

This Parsha Pearls Feast Edition is designed specifically for Yom Teruah. In Leviticus 23:1-2, Yahweh told Mosheh to speak to the children of Yisra'el about His appointed times (moadim), which they were to keep as set-apart gatherings (mikra kodesh). Three times each year, the children of Yisra'el were required to travel to Yerushalayim (Jerusalem) to observe one of the 3 pilgrimage feasts (shalosh regalim).

The 3 spring festivals are:

1. Passover (Pesach)
2. Festival of Unleavened Bread (Chag HaMatzot), which immediately follows Passover
3. Feast of Weeks (Chag HaShavuot)

The 4 autumn festivals are:

1. Day of Trumpets (Yom Teruah/Zichron Teruah/Rosh HaShanah)
2. Day of Atonement (Yom Kippur), Day of Atonements (Yom HaKippurim)
3. Feast of Tabernacles (Chag HaSukkot)
4. 8th day Assembly (Shemini Atzeret), which immediately follows Sukkot

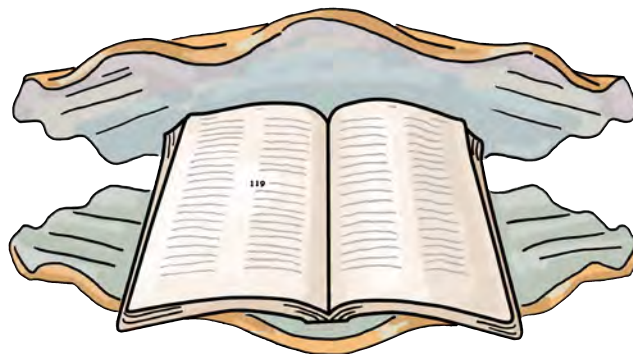

Yom Teruah is the 3rd appointed time (moad) of the year and the 4th High Sabbath. Yom Teruah/Zichron Teruah is commonly referred to as Rosh HaShanah on the calendar. It is also known as the Day of the Shofar Blast (Yom Teruah) or Remembrance of the Shofar Blast (Zichron Teruah). The term Rosh HaShanah meaning head of the year, is not found in the Torah. However, the name Rosh HaShanah is used by our brother Yehudah (Judah) because this feast marks the head of the new fiscal year. In English this feast is commonly known as the Day of Trumpets. *"Speak to the children of Yisra'el saying, 'In the 7th month (new moon), on the 1st day of the month (new moon), you have a rest, a remembrance of blowing of trumpets (Teruah), a set-apart gathering. You do no servile work, and you shall bring an offering made by fire to Yahweh'" (Lev. 23:24-25).*

These festivals were commanded by Yahweh to be kept by the children of Yisra'el throughout their generations, and that is why we are observing them as well (Lev. 23).

In parsha Beha'alotcha (Lev. 10:1-10), Yahweh told Mosheh to make 2 silver trumpets. He then gave him instruction about the different ways these trumpets were to be blown, so that when the children of Yisra'el heard any of them, they would recognize the signal and know what to do.

The Word does not give us a reason for observing this feast day other than as a 'remembrance' of blowing of trumpets (Lev. 23:24). It is certainly proper to 'remember' the events at Mt. Sinai on this festival, because when the children of Yisra'el received Yahweh's commandments there was a sounding of the shofar (Parsha Yitro - Ex. 19:13, 16, 19; 20:18).

Brother Yehudah has many ideas about what may have happened during this Sinai event, and you can research them if you would like. In Psalm 81:3-4 we are told, "*Blow the shofar (ram's horn) at the time of the New Moon, at the full moon, on our festival day. For this is a law for Yisra'el, And a right-ruling of the Elohim of Ya'aqob.*"

Now let's take a look at some of the traditions that brother Yehudah does on this day when they gather in their synagogues.

Greetings

- On this feast day, Yehudim usually greet each other with the words, "L'shanah tovah" (for a good year). This is a shortening of "L'shanah tovah tikatev v'taihatem," or to women, "L'shanah tovah tikatevi v'taihatemi," which means, "May you be inscribed and sealed for a good year."

Shofar/Trumpet Blasts

- While everyone is gathered, it is customary to hear someone blow 100 shofar blasts on a ram's horn. There are 4 different kinds of sounds that make up the 100 blasts:
 - The *Tekiah* is a long, single blast. It is a smooth, continuous note symbolizing the expression of joy and contentment.
 - The *Shevarim* are 3 short blasts. The 3 broken notes symbolize weeping.
 - The *Teruah* consists of 9 staccato notes sounded in very quick succession, like a short trill. This symbolizes trepidation, sorrow and sobbing.
 - The *Tekiah Gedolah* is the 100th blast, and means 'the last trump.' It is a very long, sustained final note, symbolizing the hope of redemption.

Apples and Honey - Bread and Honey

- It is customary to serve apples and honey as a symbol of the hope that the New Year will be sweet. It is also customary to dip the bread for the Motzi (blessing over the bread) in honey instead of the usual practice of sprinkling salt on it.

Round Loaf of Bread

- It is customary to serve a round-shaped bread for the Motzi (blessing over the bread), which symbolizes a crown.

Ten Days of Awe

- Yom Teruah begins a short period known as the 'Ten Days of Awe', which lead up to and include the next commanded feast day, Yom Kippur. It is a time of introspection, reconciliation and preparation.

Tashlich

- Brother Yehudah performs this ceremony based on Micah 7:18-19. One will throw bread or rocks into the water to symbolize 'sins' that are cast into the sea and washed away.

Common names for this day and their meanings

- Yom Teruah - a day of blowing the trumpet - Num. 29:1
- Zichron Teruah - a remembrance of blowing of trumpets - Lev. 23:24
- Rosh HaShanah - head of the year (the most common term used by brother Yehudah)

Chag Sameach (Happy Feast) from MTOI and YMTOI



Table of Contents

Parsha Pearls is a comprehensive resource that allows for complete customization by the parent. We understand that if you were to strive to accomplish all aspects of each lesson in one day it would be unrealistic and also overload for the child. It is our intention that this be used 'a la carte' so that it suits your specific needs. Our site caters to printing only the pieces you choose.

This page will provide quick links to get to the portion of the document for which you are looking. When you hover over the title a finger will appear. Click on it and you will be taken directly to that page.

If you are new to Parsha Pearls, we have created an [Introduction](#) document outlining how to use our lessons, as well as a [Scriptural Inspiration](#) document, which explains our titles and the Scriptural inspiration for them. We pray that Parsha Pearls blesses your home and that your children will grow to love the Word and to never depart from keeping Torah. As always, feel free to email us at parshapearls@mtoi.org if you have any questions.

Special Feast Edition	2
➤ Introduction	2
Gem Seeking (The Main Lesson)	6
➤ Little Gems Story (Story for Younger Children)	6
➤ Little Gems Story Characters	8
➤ Parent Guide	16
Counting What You Gained (Worksheets)	19
➤ Storing Up Treasure in My Heart (Memory Verse)	19
➤ Seeking Treasure (Questions from the Parsha)	21
➤ Word Search	22
➤ Maze	23
Precious Possessions (Arts & Crafts)	24
➤ Craft	24
➤ Coloring Page	39
Sweetness of Torah	40
➤ Sweet Sounds of Torah (Song Corresponding to the Parsha)	40
➤ Sweet Taste of Torah (Snack Corresponding to the Parsha)	41



Gem Seeking

LITTLE GEMS STORY

Parent/Teacher Preparation:

Please see the [Instructions for the Little Gems Story](#) on the YMTOI website. This will help you to understand how to prepare for the story.

Here is the link for a reading of this story:

https://www.podomatic.com/podcasts/steveberkson/episodes/2022-09-16T07_15_04-07_00

Yom Teruah Edition

Shalom children! Today we are celebrating a special feast day called Yom Teruah. Can you say it with me? Yom Te-ru-ah. In English we call this day the Feast of Trumpets. Can you guess why we would call it that? **(Let children give responses.)** Yes, it is because Yahweh wants us to celebrate this day by blowing the shofar. Do you know what a shofar is? It kind of looks like a trumpet **(place silver trumpets on board)**, but instead of being made out of metal, it is something very different. A shofar is the horn of an animal, like a ram or a kudu antelope. **(Place ram and antelope on board.)** The horns of these animals make a beautiful musical instrument. **(Place shofar-ram and shofar-antelope on board.)** Have any of you ever blown a shofar? **(Let children give responses.)** For most people it is not so easy to make a sound with it unless you practice and practice and practice.

Yahweh told His people that He wanted them to celebrate this day by doing certain things, and also by not doing certain things. Isn't it thoughtful of Yahweh to tell us just how to celebrate His feasts? **(Place caring emoji on board.)** The first thing Yahweh told His people was to celebrate this feast in the 7th month on the first day of the month. **(Place #7 coin on board.)** This means that the feast will fall sometime during the fall season. He then told them not to work on this day, but to rest. I don't know about you, but adults appreciate Yahweh telling them to take a break and not work on certain days. So on this day, daddy and mommy are not going to their usual jobs. They are going to take time off from work so that they can go to services and celebrate this day. You know what that means for you? No chores to do. **(Place girl sweeping and boy taking trash out on board.)** I kind of like that rule, don't you?

The next thing Yahweh told them is what they need to do. He told them that they need to have a set-apart gathering. That means that you will do just as you do on Shabbat. You will go to services and see your friends. **(Place friends hugging on board.)** Isn't that awesome? He also told them that Yom Teruah is a day to remember the blowing of the shofar. **(Point to shofars on board.)** When I think of a shofar blowing, it reminds me of a very special event we read about in Scripture. Can you guess what it is? Yes, it's the story of the Yisra'elites receiving Yahweh's commandments at Mt. Sinai. **(Place Mt. Sinai on board.)**



That day, the Yisra'elites were standing near the mountain, waiting to hear Yahweh's voice with their own ears. Finally, the moment came. They heard loud thunder and saw many flashes of lightning. A thick cloud covered the mountain. **(Place cloud with lightning and thunder over mountain.)** And as if that wasn't enough, there was a shofar sounding from the mountain top, louder than anything they'd ever heard. The whole mountain was covered in smoke, because Yahweh had come down on the mountain like fire **(place fire with smoke above cloud)**, and the mountain was shaking. Can you imagine a mountain shaking?

When the people heard and saw so many amazing things happening at once, they got really scared. The blast of the ram's horn sounded for a long time, and kept getting louder and louder. **(Point to mountain.)** They saw the smoke all over the mountain and heard the voice of Yahweh talking. They begged for Mosheh to ask Yahweh to stop. They wanted to go back to the usual way of just having Mosheh tell them what Yahweh said, instead of having to hear His awesome voice for themselves. So Mosheh told them not to worry, because Yahweh was only letting them hear Him so they would know He was real. He meant for them to see how great He was, so that they would understand that He was always to be respected and obeyed.

I can't imagine how amazing it would be to witness that event. I bet that was the loudest and strongest shofar blast ever! **(Remove all characters from the board.)**

Ok, we are not done learning about the things Yahweh wanted them to do. Do you remember learning about some of the offerings that Yahweh wanted? Well, Yahweh wanted His people to bring certain kinds of those offerings to the priest on Yom Teruah. **(Place man by sheep and priest on board.)** These offerings were a sweet smell to Yahweh, because they were meant to be a way for the people to show Yahweh that they were obedient. We don't do those offerings today because the Temple is gone. **(Place Dwelling Place on board.)** But back when they did have Yahweh's tabernacle among them, the priests received offerings every day. **(Place priest by altar on board.)** Can you imagine that? I'm sure that was a lot of work.

On Yom Teruah, Yahweh wanted 1 young bull, 1 ram and 7 lambs that were a year old and perfect **(place bull, ram and lambs on board)**. We call these offerings burnt offerings. The next offering that Yahweh wanted was the grain offering, **(place flour and oil in dish on board)** as well as 1 male goat for a sin offering **(place goat on board)**. These are the special offerings that Yahweh wanted for this feast day, besides the daily offerings and the New Moon offerings **(place new moon on board)**.

Many believe that Yeshua will return on Yom Teruah, because Scripture says that He will return with the sound of the trumpet - and that is definitely an exciting thing! **(Point to silver trumpets on board.)** Children, can you say Chag Sameach to wish each other a Happy Feast? Chag Sameach!

Well children, we have come to the end of our story for today. We will see you next time for another exciting Little Gems story!



Lambs

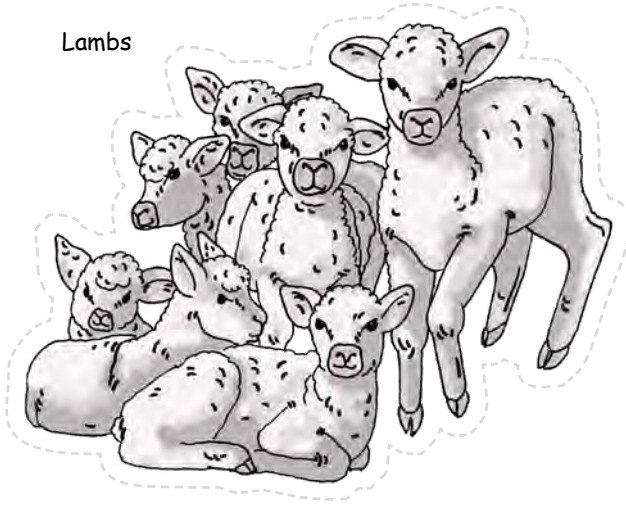

Goat

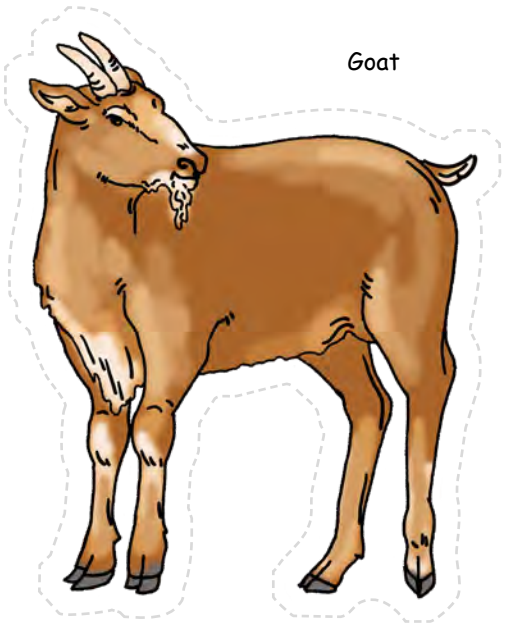

Bull

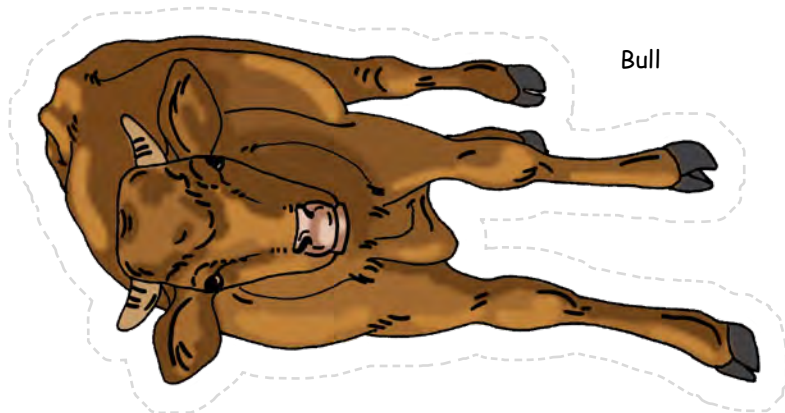

Antelope

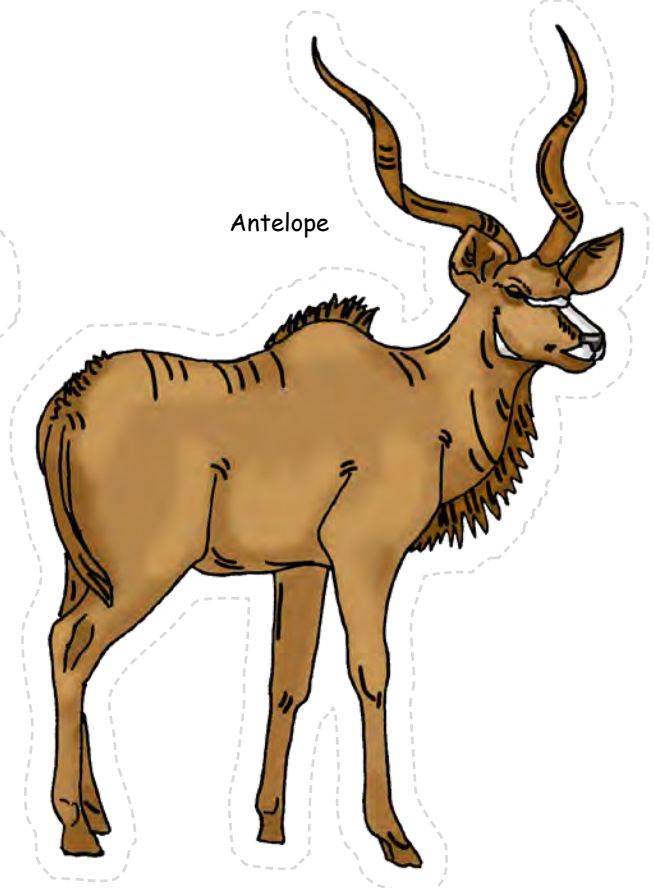

Ram

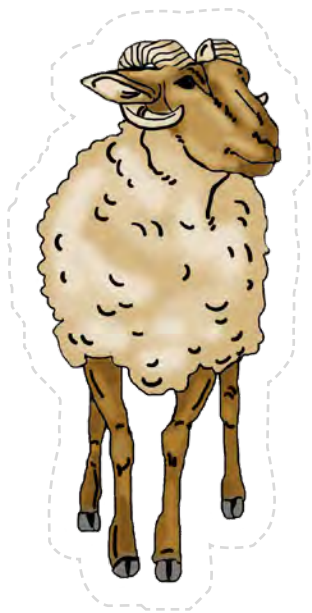

Shofar (ram)



Shofar (antelope)

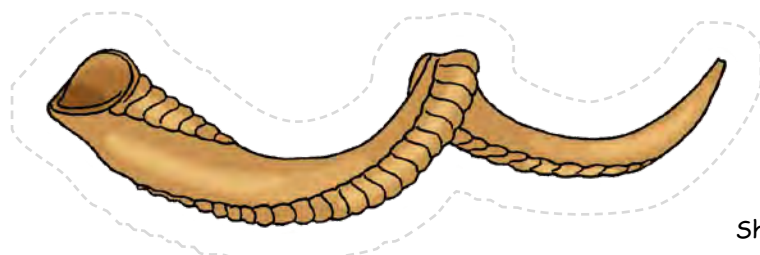

Girl sweeping



Flour and oil in dish



#7 coin



New moon

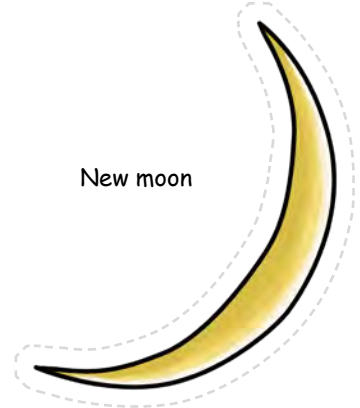

Silver trumpets

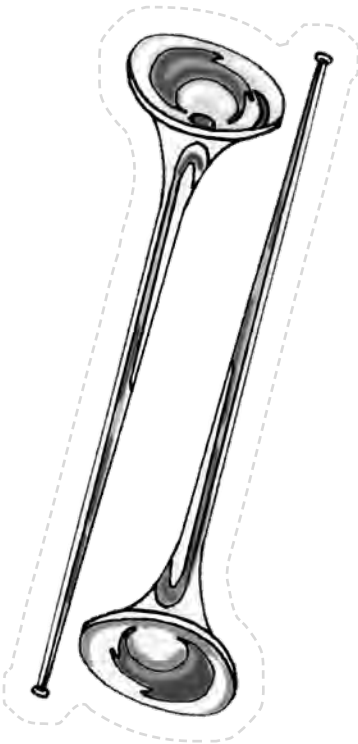

Friends hugging



Man by sheep



Cloud with lightning and thunder

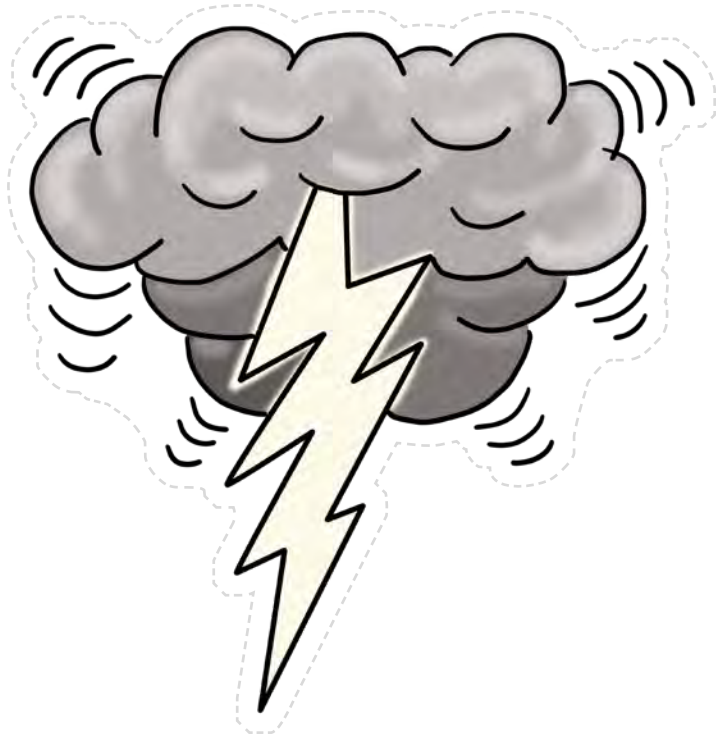

Fire with smoke



Priest by altar

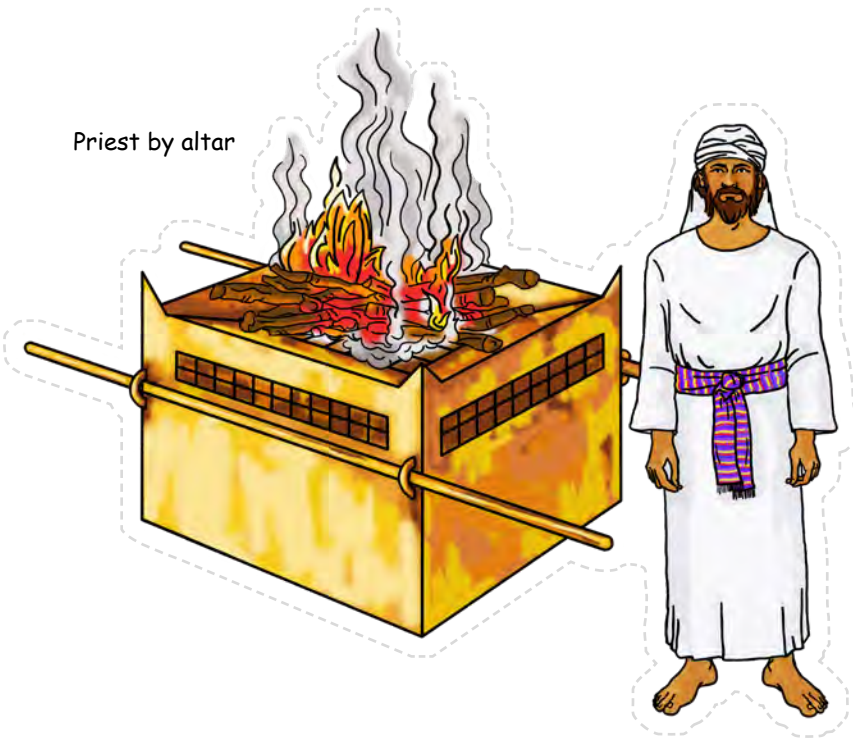

Priest



Dwelling Place

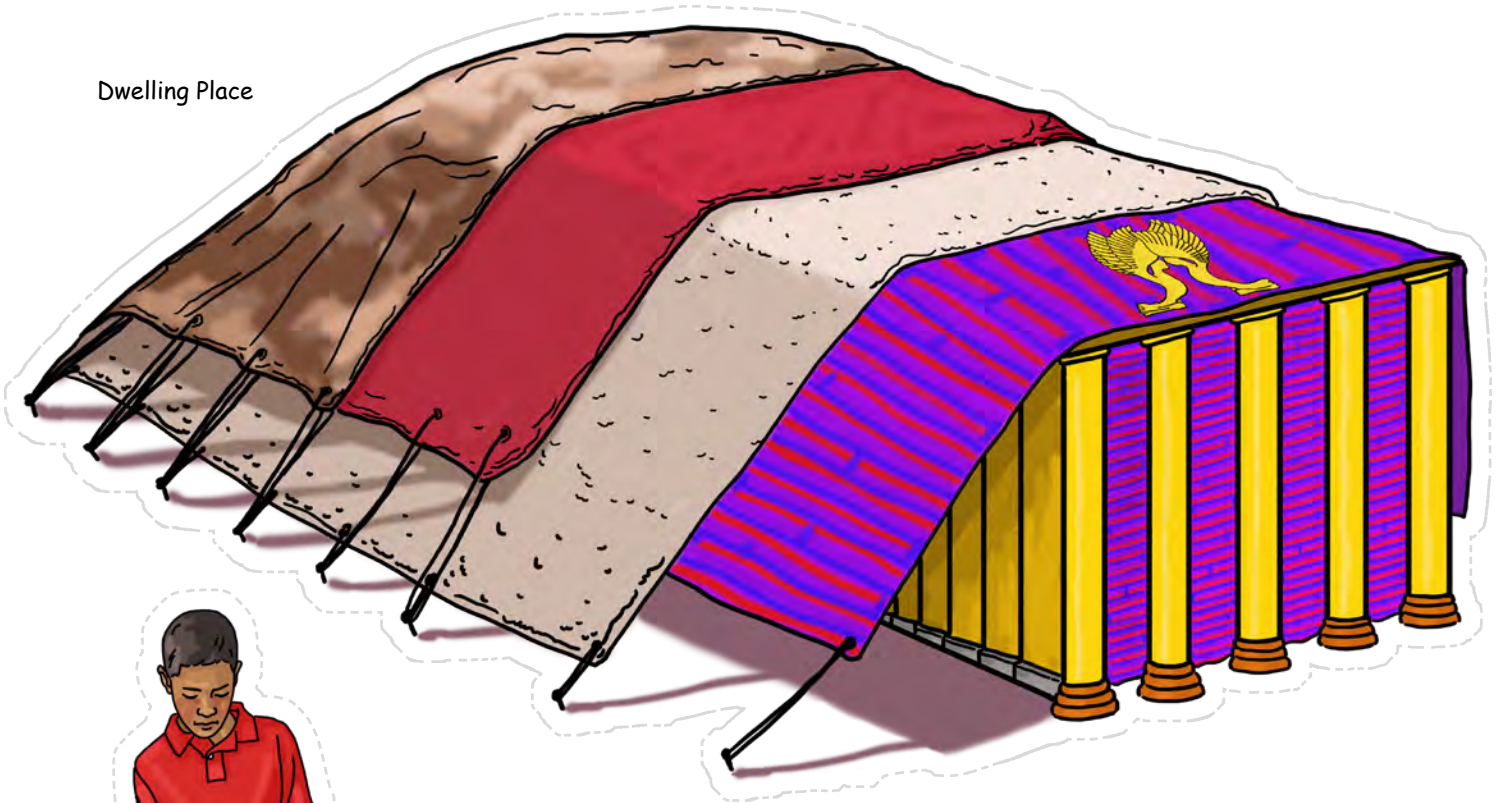

Boy taking out trash



Caring emoji



Mt. Sinai

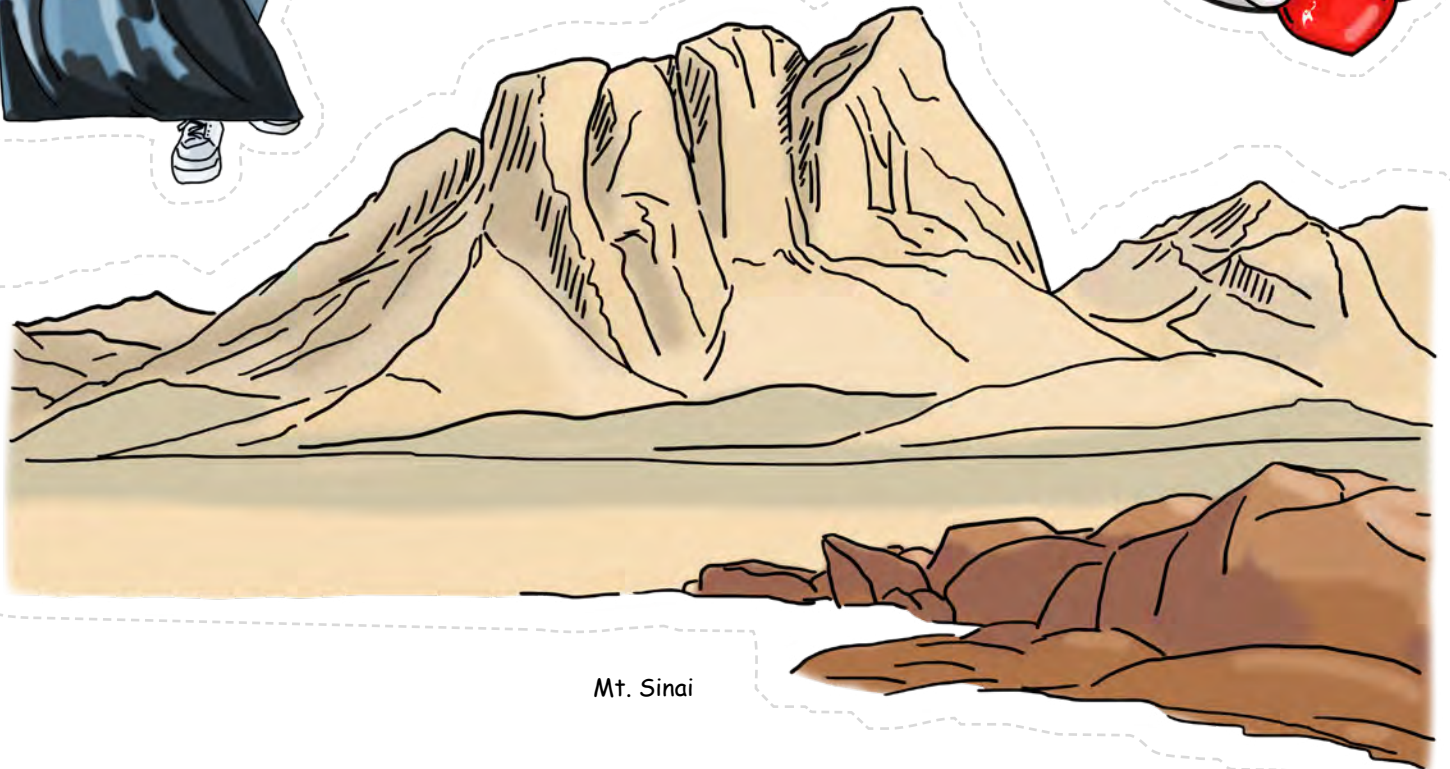

Lambs

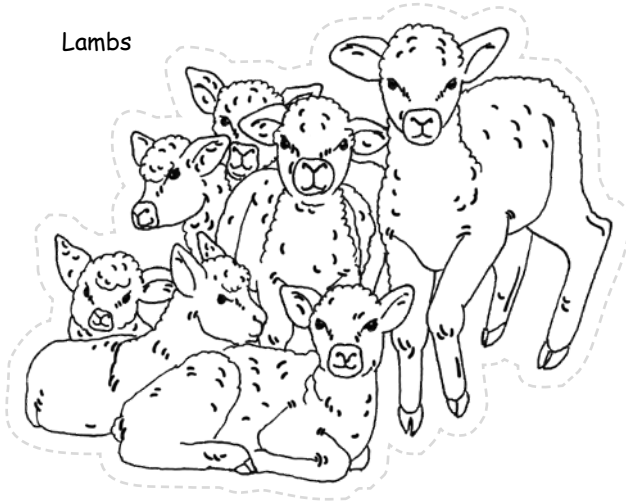

Goat

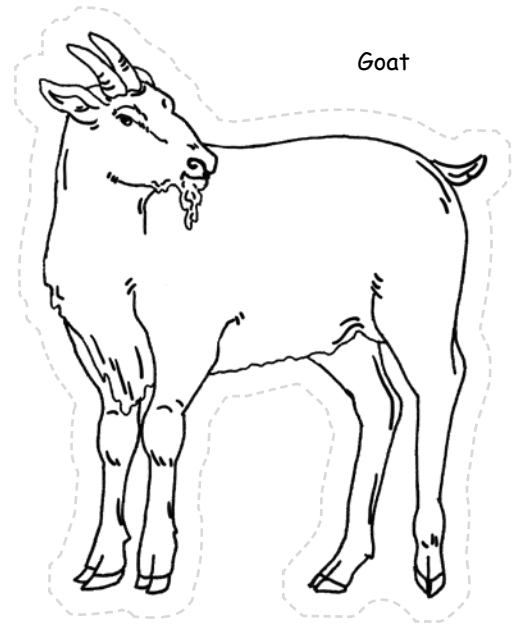

Bull

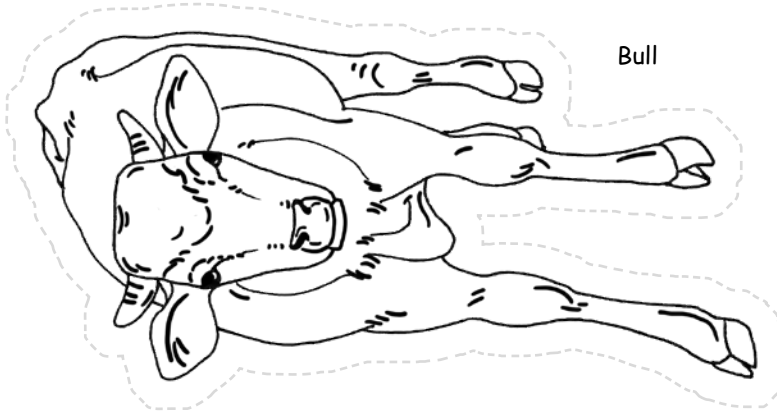

Antelope

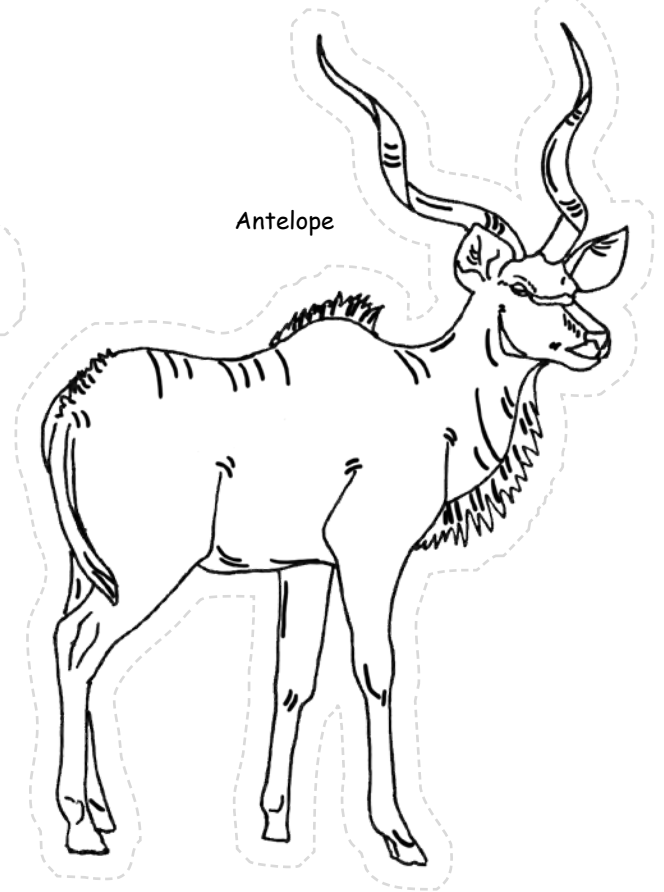

Ram

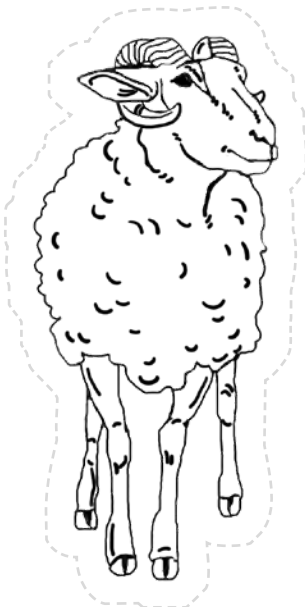

Shofar (ram)

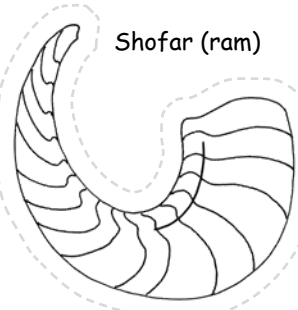

Shofar (antelope)

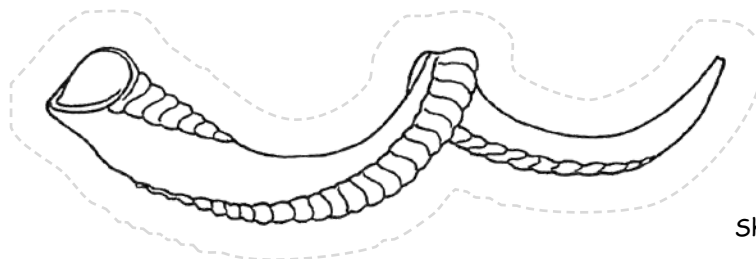

Girl sweeping



Flour and oil in dish

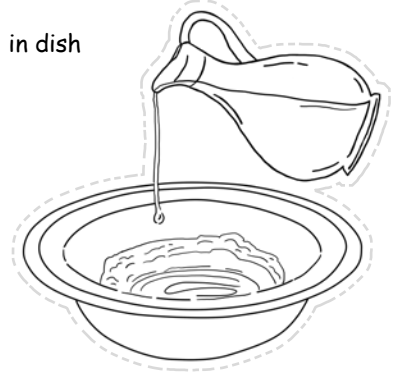

#7 coin



New moon

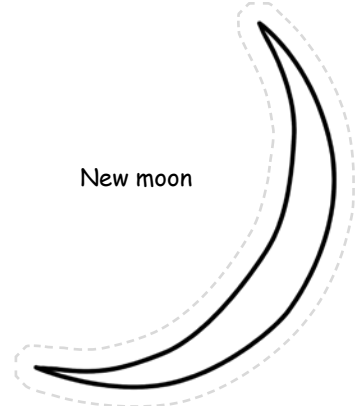

Silver trumpets

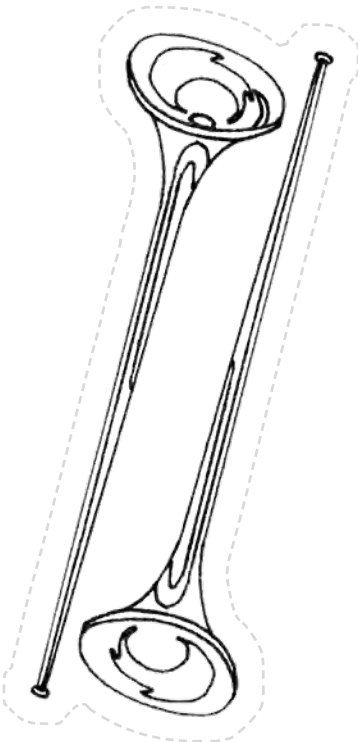

Friends hugging



Man by sheep



Cloud with lightning and thunder

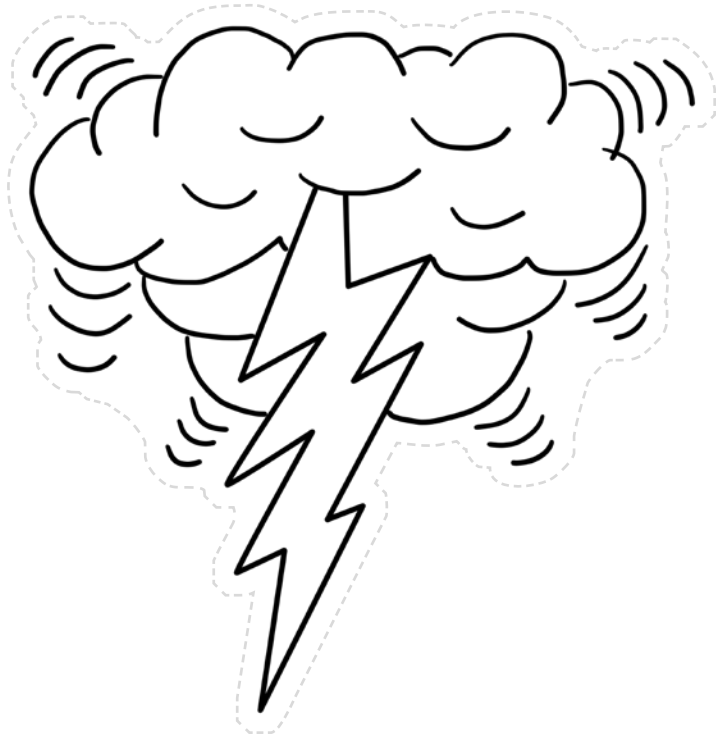

Fire with smoke



Priest by altar

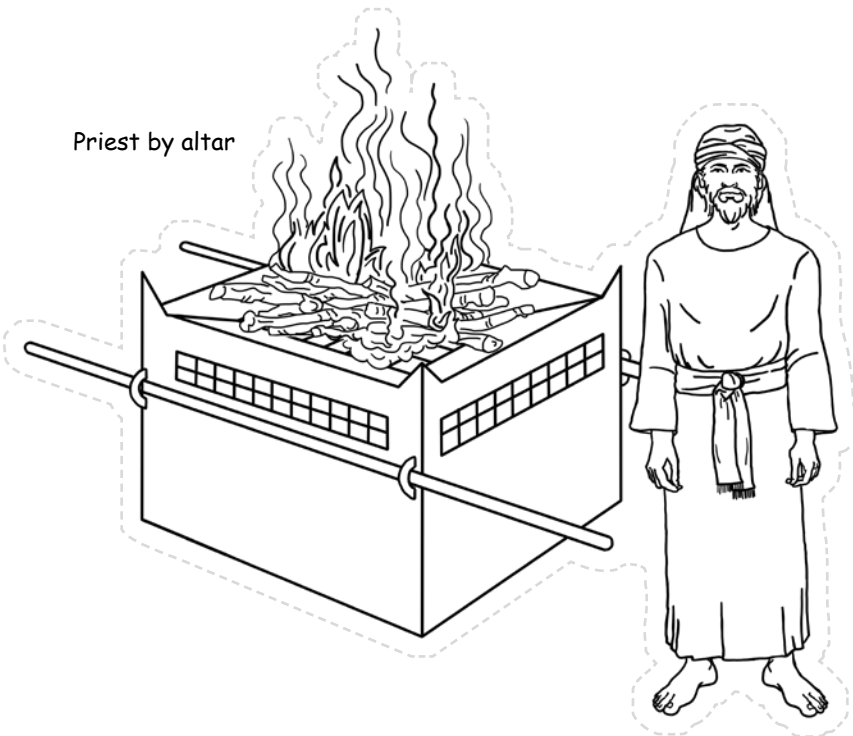

Priest

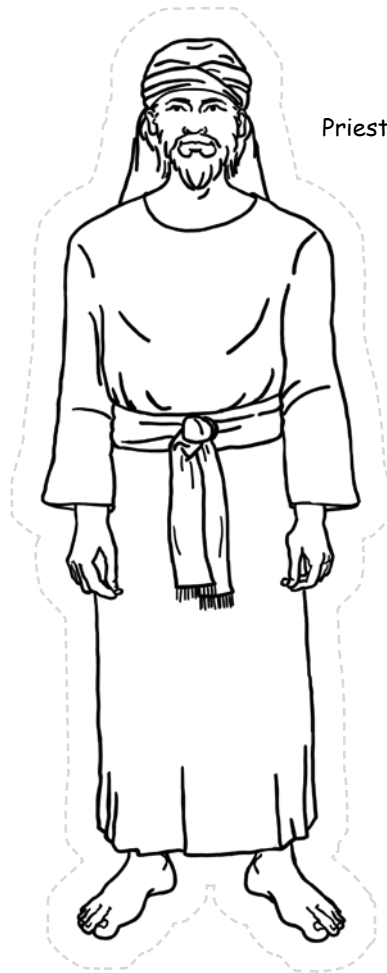

Dwelling Place



Boy taking out trash



Caring emoji

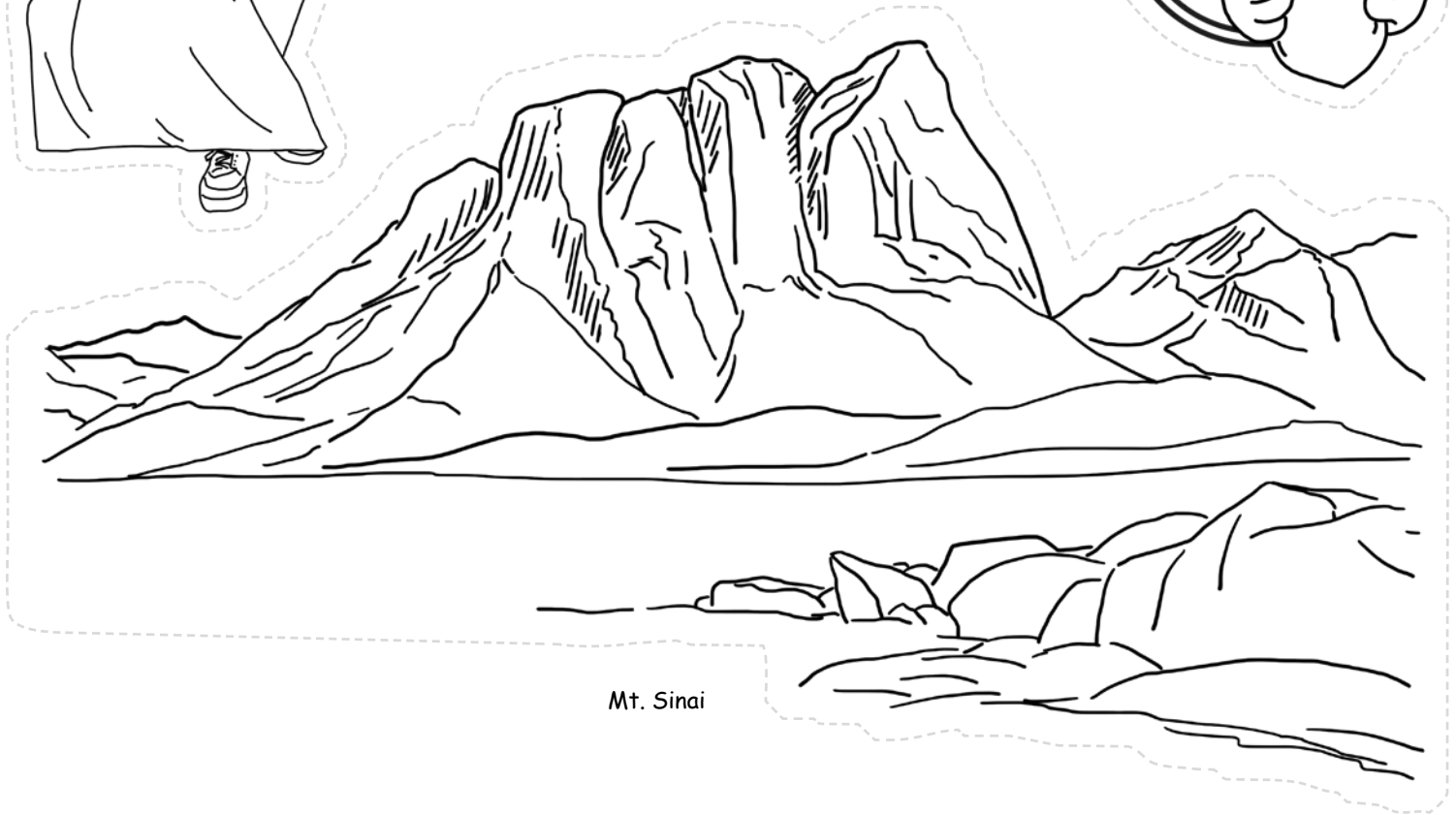

Mt. Sinai

PARENT GUIDE

This visual guide is to help parents and teachers explain the offerings required for Yom Teruah (Num. 29:2-6).

- **Burnt (Ascending) Offerings** (as a sweet fragrance to Yahweh) along with their **Grain (Meal) Offering** (Num. 29:2-5)



+



1 young bull +
3/10s of an
ephah of fine
flour mixed with
oil for the bull



+



1 ram + 2/10s of
an ephah of fine
flour mixed with
oil for the ram



+



7 lambs a year
old, perfect
ones + 1/10 of
an ephah of fine
flour mixed with
oil for each of
the 7 lambs

- **Sin Offering** (to make atonement for you)



1 male goat

- **Daily (Continual) Burnt (Ascending) Offerings** along with their **Grain (Meal) Offering** and **Drink Offering** (Num. 28:3-8;29:6)

In the morning:



+



+



1 male lamb, a year old,
perfect one

1/10 of an ephah of
fine flour mixed with
1/4 of a hin of pressed
oil

1/4 of a hin of wine for
each lamb to be poured
out in the Set-apart
Place to Yahweh

Between the evenings:



+



+



1 male lamb, a year old,
perfect one

1/10 of an ephah of
fine flour mixed with
1/4 of a hin of pressed
oil

1/4 of a hin of wine for
each lamb to be poured
out in the Set-apart
Place to Yahweh

- **Burnt (Ascending) Offerings** for the New Moon (beginning of month), along with their **Grain (Meal) Offering** and **Drink Offering** (Num. 28:11-15;29:6)



+



+



2 young bulls +
3/10s of an ephah
of fine flour mixed
with oil for each
bull + 1/2 of a hin
of wine for a bull



+



+



1 ram + 2/10s of an
ephah of fine flour
mixed with oil for
the 1 ram + 1/3 of
a hin of wine for a
ram



+



+



7 lambs a year
old, perfect ones
+ 1/10 of an ephah
of fine flour mix
with oil for each
lamb + 1/4 of a hin
of wine for each
lamb

- **Sin Offering** (to make atonement for you)



1 male goat

Counting What You Gained

This next section is intended to be reinforcement of the lessons learned during this lesson. Choose the activities that best fit your child.

STORING UP TREASURE IN MY HEART

The Katan Aleph memory verse is Numbers 29:1. If they have not already done so, begin to help them to memorize the verse. Be creative and try acting it out, or putting it to music.



Numbers 29:1

And in the seventh new moon,
on the first day of the new
moon, you have a set-apart
gathering, you do no servile
work, it is Yom Teruah.

MEMORY VERSE

Here is the link for this song:

https://www.podomatic.com/podcasts/steveberkson/episodes/2021-09-02T21_08_03-07_00

Use this space to draw a picture of the verse memorized.

Large empty rectangular box for drawing.

Use this space to write out the verse memorized.

Series of horizontal lines for writing the verse.



SEEKING TREASURE

Circle the correct choices.

1. On which month did Yahweh say the festival of Yom Teruah was to be celebrated? (Lev. 23:24)



2. Yahweh said that this was a day of remembering to do what? (Lev. 23:24)



3. Which image represents the correct amount of animal sacrifices for the burnt offering? (Num. 29:2)



4. Which image best represents the grain offering required for Yom Teruah? (Num. 29:3-4)

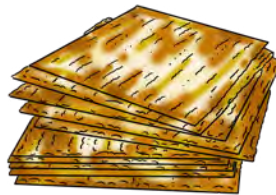

5. Which animal was sacrificed for the sin offering? (Num. 29:5)



young bull



ram



goat



lamb

WORD SEARCH

Search for the hidden words from this week's lesson.

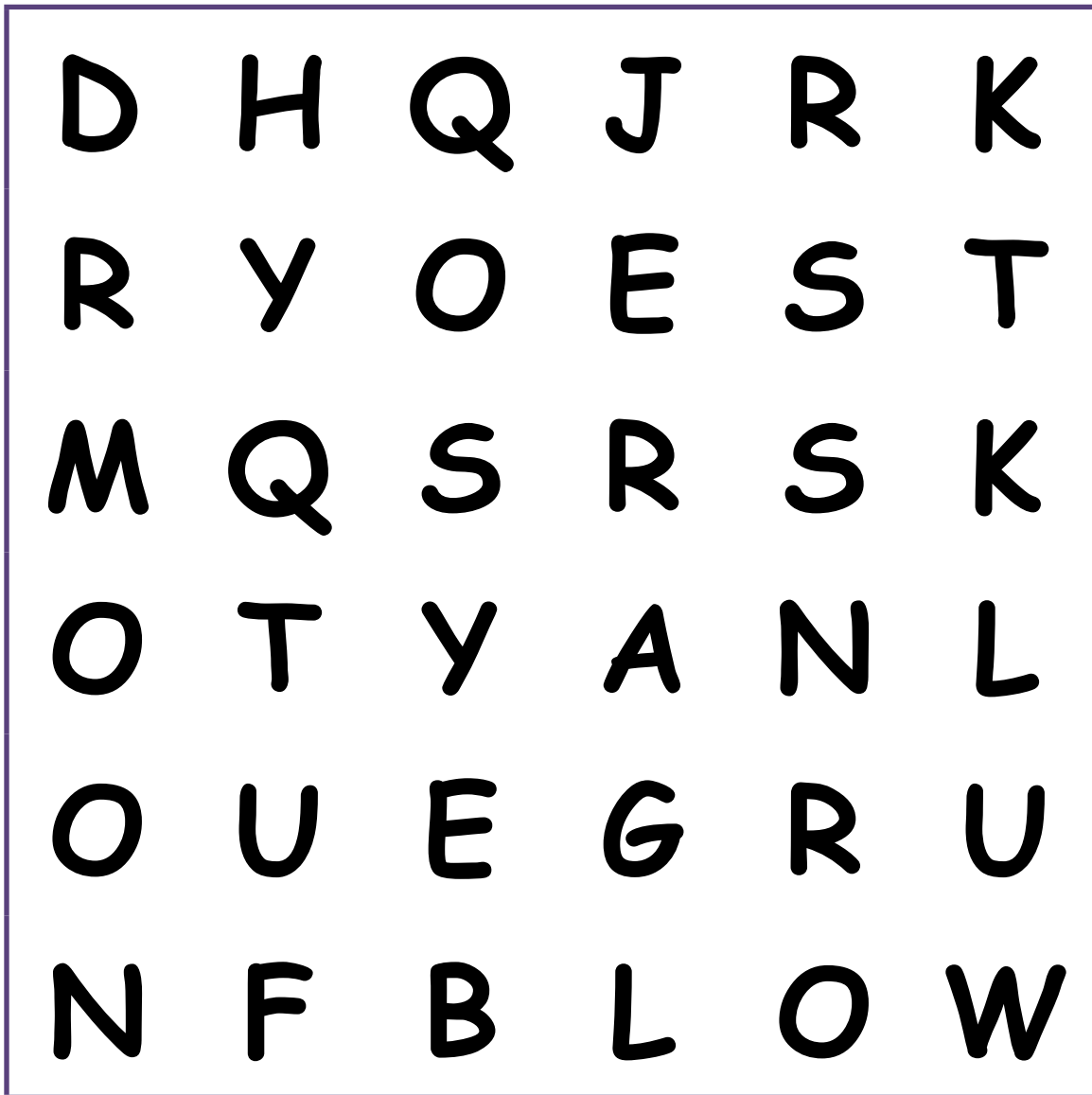

BLOW
HORN
MOON
REST
FEAST



MAZE

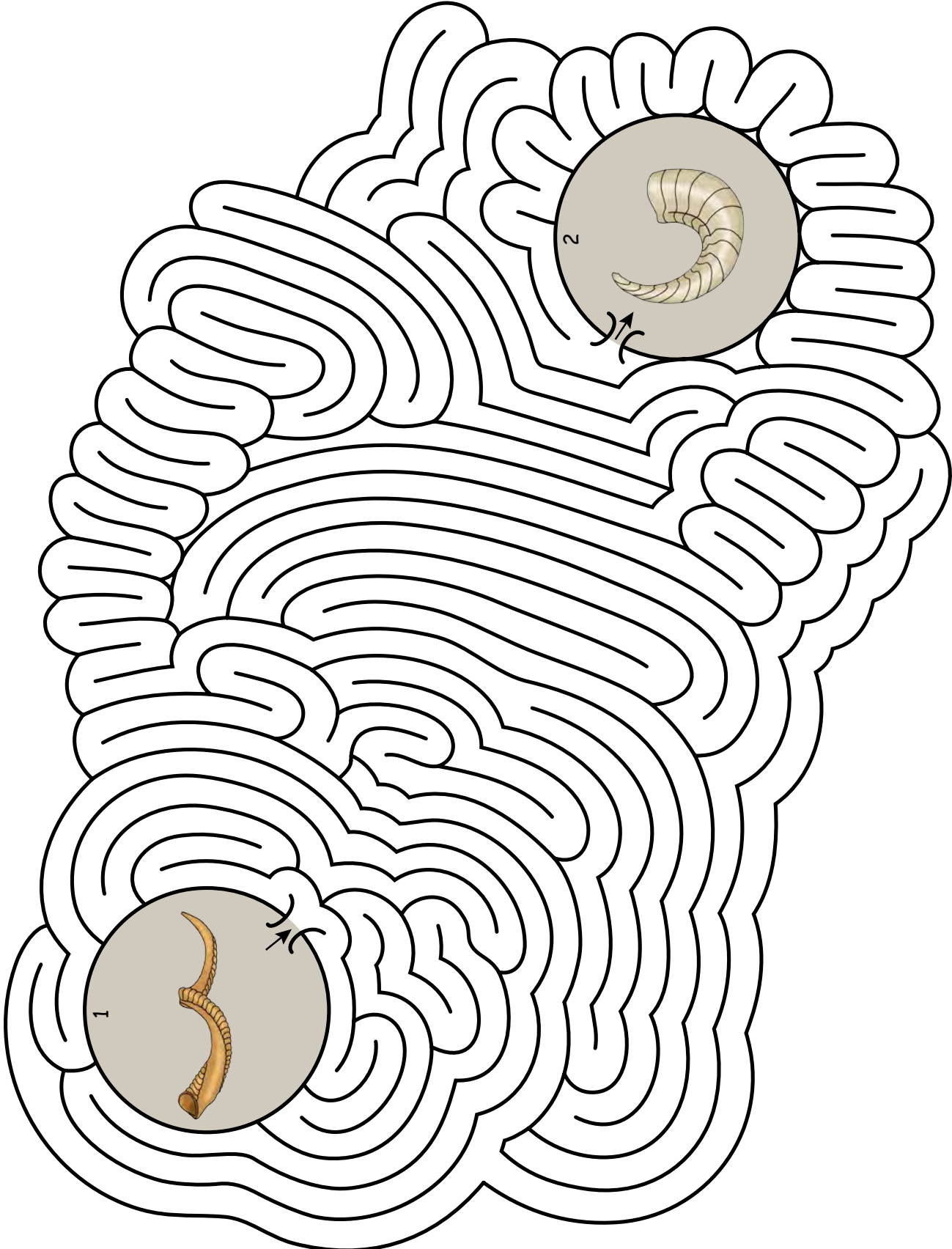

Precious Possessions

CRAFT

Materials:

- Copy paper - red & green
- Toilet paper roll (for apple core)
- Puncturing tool
- Hole punch
- Rubber bands
- Pipe cleaner - brown (6")
- Glue or glue stick
- Scissors
- Craft Templates: A & B

Parent/Teacher Preparation:

- Print Craft Template A on red copy paper.
- Print Craft Template B on green copy paper.

Instructions for the Craft:

- Cut out all Template pieces. (P1)

Apple Core

- Roll glue stick onto piece 'A' (red rectangle). (P2)
- Take the glued red rectangle 'A' piece and roll it over the toilet paper roll making sure one end comes flush to the edge of the toilet paper roll. (P3a, P3b)
- Depending on the size of the toilet paper roll, you may need to trim the other side of the red rectangle 'A' piece.
- Set aside to dry.

Apple

- Take piece 'B' (apple) and fold it in half. (P4a)
- Using scissors, cut along the black lines. Do NOT cut all the way across. (P4b)
- Pull each strip in opposite directions to form the apple. (P4c)
- Set aside.

Apple Candy Box

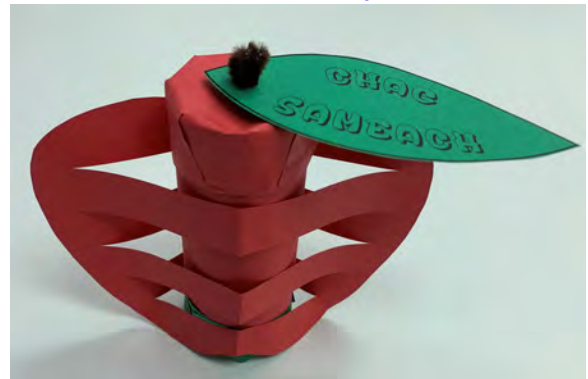

P1



P2

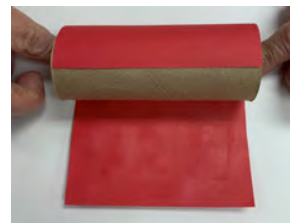

P3a



P3b

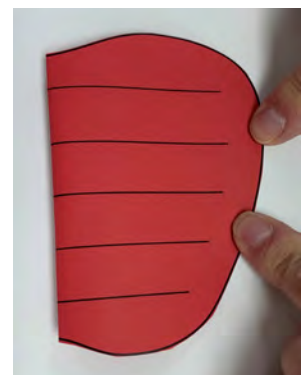

P4a

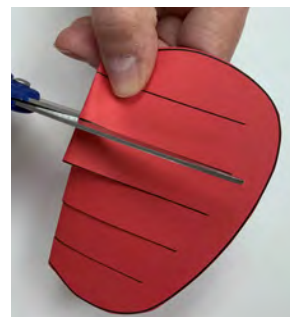

P4b



P4c

Instructions for the Craft Cont'd:

Top and Bottom of Apple Core

- Take piece 'C' and 'E' (red and green skirts) and cut the black lines. (P5a, P5b)
- Now, take piece 'D' and 'F' (red and green strips) and fold in half lengthwise. (P6)
- Starting with 'D' red strip which is for the top, make a ring around the toilet paper roll core and glue it to itself, being careful not to glue it permanently to the roll. (P7a, P7b)
- This strip just adds strength to piece 'C' (red skirt) which will go over it. (P7c)
- Place glue all around 'D' red strip. (P7c)
- Now, take piece 'C' (red skirt) and place it over the top of the apple core. (P8a)
- Start folding every other 'skirt' piece onto the glue. (P8b, P8c)
- Then add more glue to the other 'skirt' pieces and fold them over the already glued 'skirt' pieces. (P8d)
- You may need to add extra glue to some of the ends to make sure they lay down and are secure on the strip. Be careful not to glue the 'skirt' pieces to the apple core as this will be a removable lid. (P8e)
- We recommend putting a rubber band around the 'skirt' pieces to shape and secure until dry. (P9)
- Now, take the folded 'F' green strip and place glue on it. (P10a)
- Glue it around the bottom of the apple core. (P10b)
- Apply glue to the green strip. (P10c)
- Take piece 'E' (green skirt) and place over the bottom of the apple core.
- Alternate folding the 'skirt' pieces over the glue. (P11a)
- Apply glue to the other 'skirt' pieces and fold them over the bottom of the apple core. (P11b)
- We recommend using a rubber band to shape and secure the bottom until dry. (P12)



P5a

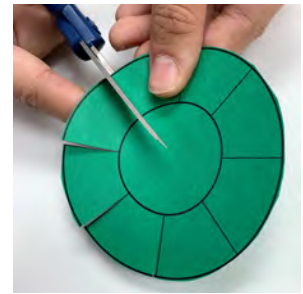

P5b



P6

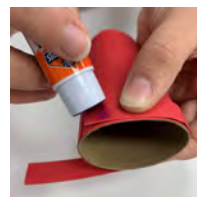

P7a



P7b



P7c



P8a



P8b



P8c



P8d



P8e



P9



P10a



P10b



P10c



P11a



P11b



P12

Instructions for the Craft Cont'd:

Apple Stem and Leaf

- Once the lid and bottom are dry, remove the rubber bands. (P13)
- Using a puncturing tool, poke a hole through the center of the lid. (P14)
- Thread a 6" brown pipe cleaner through the hole and fold and twist the end a few times to prevent it from coming back through the lid. (P15a, P15b)
- Use a hole punch through the leaf making sure the words "Chag Sameach" are facing the right direction. (P16)
- Thread the other end of the pipe cleaner through the leaf and cut off some of the length. Leave enough to twist and bend the pipe cleaner onto the lid to represent a stem. (P17a, P17b)

Finishing the Apple

- Gently slide piece 'B' (apple) through the apple core alternating the cut slits in front and behind the core. (P18)
- You can fill your apple candy box with sweet treats to enjoy this festival. It can also be used as a table centerpiece. (P19)

You now have a visual representation of a common fruit eaten on Rosh Hashanah as well as a festive decorative piece for your table setting.



P13



P14



P15a



P15b



P16



P17a



P17b



P18



P19

Craft Template A

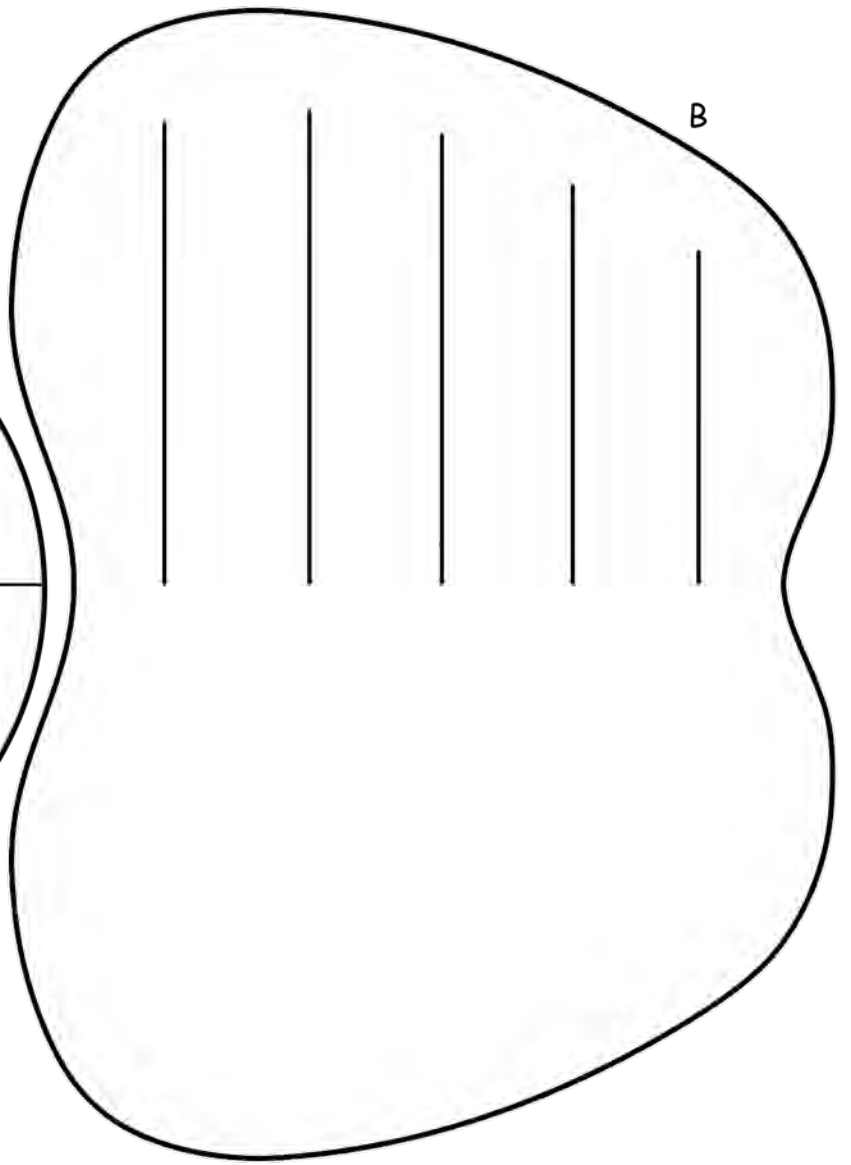
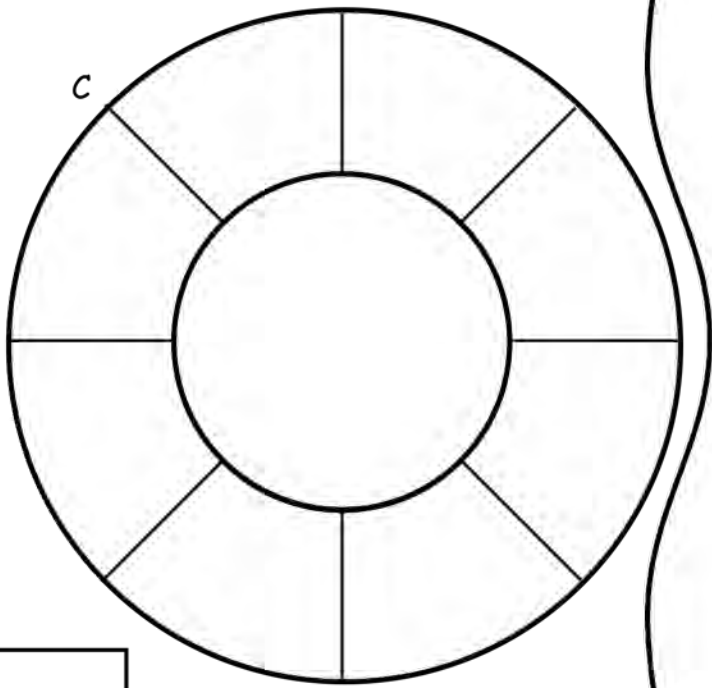

Craft Template B



F

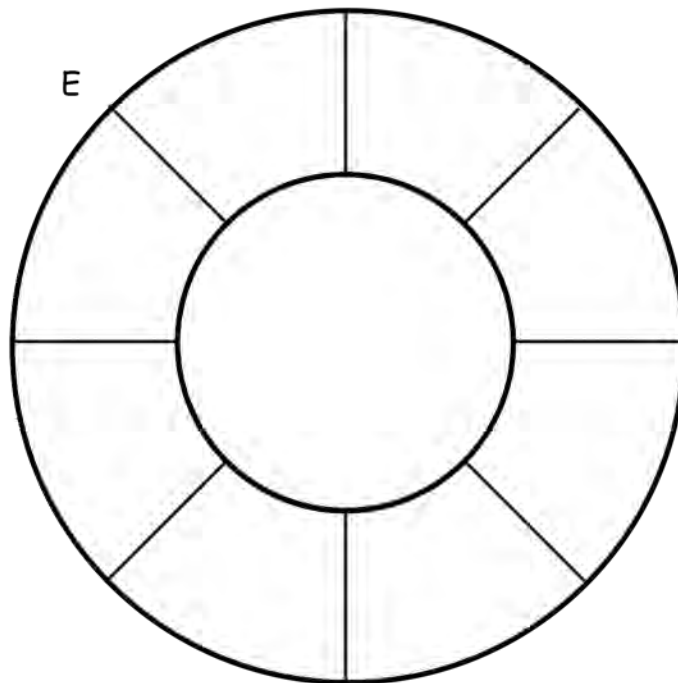

CRAFT

Apple & Honey Felt Finger Puppet

Materials:

- Copy paper
- Felt - blue, tan, red, yellow, green, brown
- Hot glue or glue
- Permanent marker - black (ultra fine tip)
- Double-sided tape
- Scissors
- Craft Template: Apple & Honey A (BW)

Parent/Teacher Preparation:

- Print Craft Template on copy paper.
- Depending on the skill of the child, you may need to assist them in cutting out the Template and felt pieces.
- A video tutorial of this craft can be viewed at:
<https://youtu.be/NQw5gM6hIkI>



Instructions for the Craft:

- Cut out all Template pieces. (P1)
- Place Template pieces on felt pieces, using double-sided tape to hold them in place if desired. Be sure to match each template piece to the color of felt designated on the template. (P2)
- Cut the felt pieces by cutting around the templates you have just placed on the felt. (P2)
- Apply glue to the edges of the 2 background pieces and put them together, making sure to leave an opening at the bottom. (P3)
- Using the black permanent marker, mark lines on the honey pot and honey, referring to the apple & honey puppet image on the template for placement. (P4)
- Glue the honey pot, honey, apple, apple stem, and apple leaves onto the background, referring to the apple & honey puppet image on the template for placement. (P5)
- Set apple & honey felt finger puppet aside to allow the glue to dry.



P1



P2



P3



P4

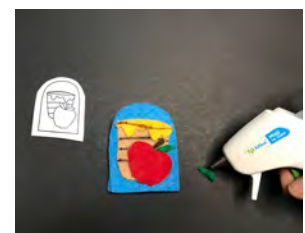

P5

CRAFT

Materials:

- Copy paper
- Glue stick or glue
- Craft stick - jumbo
- Scissors
- Craft Template: Apple & Honey B (color)

Parent/Teacher Preparation:

- Print Craft Template on copy paper.
- Depending on the skill of the child, you may need to assist them in cutting out the Template pieces.
- A video tutorial of this craft can be viewed at: <https://youtu.be/NQw5gM6hKI>

Apple & Honey Paper Stick Puppet

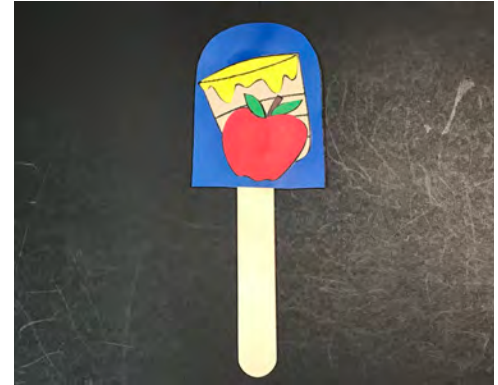

Instructions for the Craft:

- Cut out all Template pieces. (P1)
- Apply glue to the edges of the 2 background pieces and put them together, making sure to leave an opening at the bottom. (P2)
- Glue the honey pot, honey, apple, apple stem, and apple leaves onto the background, referring to the apple & honey puppet image on the template for placement. (P3)
- Apply glue to both sides of the top 1/3 of a jumbo craft stick and insert into the opening at the bottom of the apple & honey puppet. (P4)
- Press the puppet against the craft stick on both sides to adhere. (P5)
- Set apple & honey stick puppet aside to allow the glue to dry.



P1

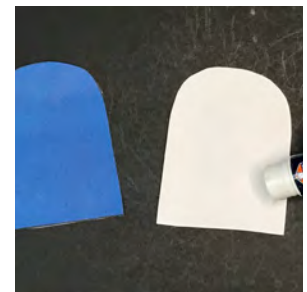

P2

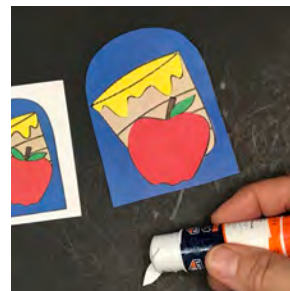

P3



P4

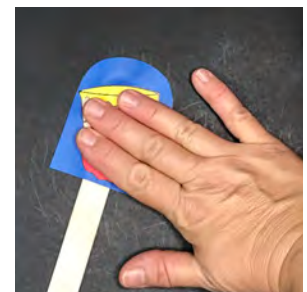

P5

CRAFT

Torah Scroll Felt Finger Puppet

Materials:

- Copy paper
- Felt - green, tan
- Cotton swabs - with the cotton removed (2)
- Permanent marker - black (ultra fine tip)
- Hot glue
- Double-sided tape
- Scissors
- Craft Template: Torah Scroll A (BW)

Parent/Teacher Preparation:

- Print Craft Template on copy paper.
- Depending on the skill of the child, you may need to assist them in cutting out the Template and felt pieces.
- A video tutorial of this craft can be viewed at:
<https://youtu.be/vu3JTLaZi8I>



Instructions for the Craft:

- Cut out all Template pieces. (P1)
- Place Template pieces on felt pieces, using double-sided tape to hold them in place if desired. Be sure to match each template piece to the color of felt designated on the template. (P2)
- Cut the felt pieces by cutting around the templates you have just placed on the felt. (P2)
- Using the black permanent marker, color one inch on each end of the 2 cotton swab sticks and set them aside. (P3)
- Apply glue to the edges of the 2 background pieces and put them together, making sure to leave an opening at the bottom. (P4)
- Hot glue the 2 cotton swab sticks to the ends of the white felt. (P5)
- Roll them inward to create a Torah scroll. (P6)
- Glue the Torah scroll onto the background. (P6)
- Set Torah scroll felt finger puppet aside to allow the glue to dry.



P1



P2

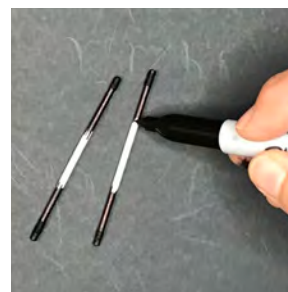

P3



P4



P5



P6

CRAFT

Materials:

- Copy paper
- Glue stick or glue
- Craft stick - jumbo
- Scissors
- Craft Template: Torah Scroll B (color)

Parent/Teacher Preparation:

- Print Craft Template on copy paper.
- Depending on the skill of the child, you may need to assist them in cutting out the Template pieces.
- A video tutorial of this craft can be viewed at: <https://youtu.be/vu3JTLAzi8I>

Torah Scroll Paper Stick Puppet



Instructions for the Craft:

- Cut out all Template pieces. (P1)
- Apply glue to the edges of the 2 background pieces and put them together, making sure to leave an opening at the bottom. (P2)
- Glue the Torah scroll onto the background, referring to the Torah scroll puppet image on the template for placement. (P3)
- Apply glue to both sides of the top 1/3 of a jumbo craft stick and insert into the opening at the bottom of the Torah scroll puppet. (P4)
- Press the puppet against the craft stick on both sides to adhere. (P5)
- Set Torah scroll stick puppet aside to allow the glue to dry.



P1



P2

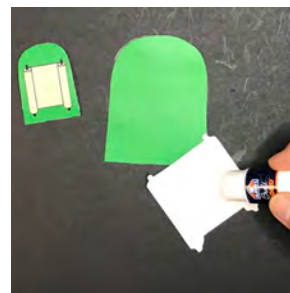

P3



P4

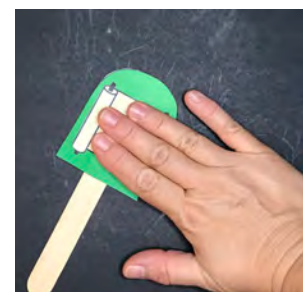

P5

CRAFT

Shofar Felt Finger Puppet

Materials:

- Copy paper
- Felt - red, tan
- Permanent marker - black (ultra fine tip)
- Glue sticks
- Hot glue
- Double-sided tape
- Scissors
- Craft Template: A (BW)

Parent/Teacher Preparation:

- Print Craft Template on copy paper.
- Depending on the skill of the child, you may need to assist them in cutting out the Template and felt pieces.
- A video tutorial of this craft can be viewed at:
<https://youtu.be/NeO7DxAyirk>



Instructions for the Craft:

- Cut out all Template pieces. (P1)
- Place Template pieces on felt pieces, using double-sided tape to hold them in place if desired. Be sure to match each template piece to the color of felt designated on the template. (P2)
- Cut the felt pieces by cutting around the templates you have just placed on the felt. (P3)
- Using the black permanent marker, draw the lines on the shofar, referring to the shofar puppet image on the template for placement. (P4)
- Apply glue to the edges of the 2 background pieces and put them together, making sure to leave an opening at the bottom. (P5)
- Glue the shofar onto the background, referring to the shofar puppet image on the template for placement. (P5)
- Set the shofar felt finger puppet aside to allow the glue to dry.



P1

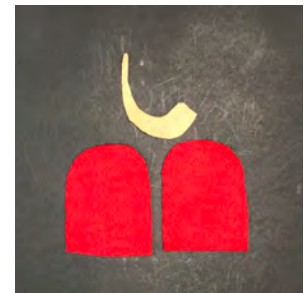

P2



P3



P4



P5

CRAFT

Materials:

- Copy paper
- Glue stick or glue
- Craft stick - jumbo
- Scissors
- Craft Template: B (color)

Parent/Teacher Preparation:

- Print Craft Template on copy paper.
- Depending on the skill of the child, you may need to assist them in cutting out the Template pieces.
- A video tutorial of this craft can be viewed at: <https://youtu.be/Ne07DxAYirk>

Shofar Paper Stick Puppet



Instructions for the Craft:

- Cut out all Template pieces. (P1)
- Apply glue to the edges of the 2 shofar background pieces and put them together, making sure to leave an opening at the bottom. (P2)
- Glue the shofar onto the background, referring to the shofar puppet image on the template for placement. (P3)
- Apply glue to both sides of the top 1/3 of a jumbo craft stick and insert into the opening at the bottom of the shofar puppet. (P4)
- Press the puppet against the craft stick on both sides to adhere. (P5)
- Set shofar stick puppet aside to allow the glue to dry.



P1

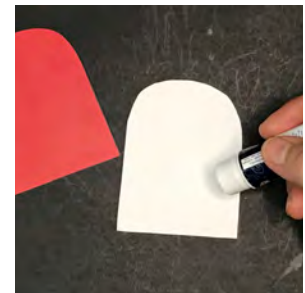

P2



P3

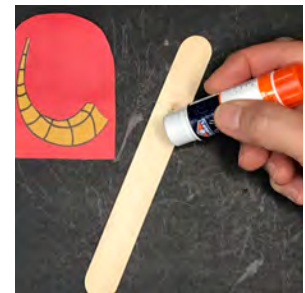

P4

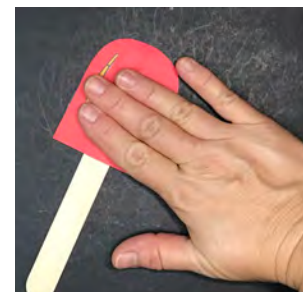

P5



APPLE & HONEY

TEMPLATE FOR FELT PUPPET

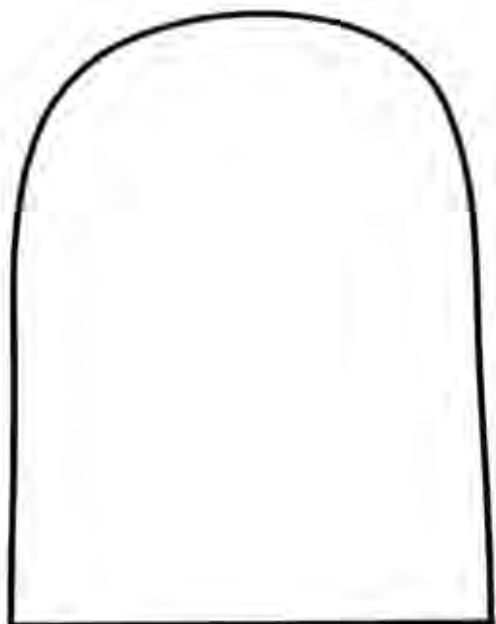

BACKGROUND

BLUE
CUT 2



APPLE STEM

BROWN

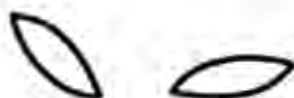

APPLE LEAVES

GREEN



APPLE

RED



HONEY POT

TAN

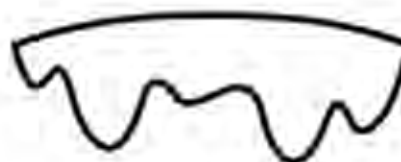

HONEY

YELLOW

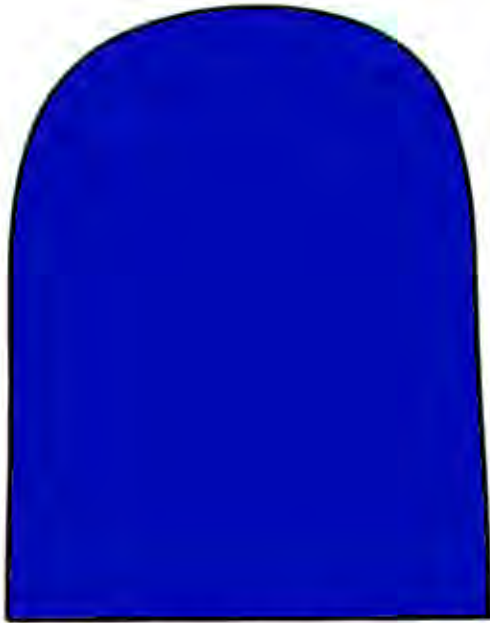

BACKGROUND FRONT



APPLE STEM



APPLE LEAVES



APPLE & HONEY

TEMPLATE FOR
STICK PUPPET

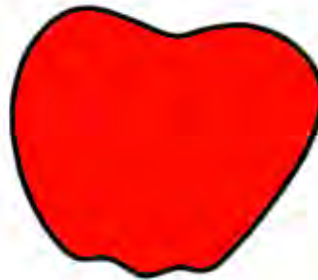

APPLE



HONEY



BACKGROUND BACK



HONEY POT

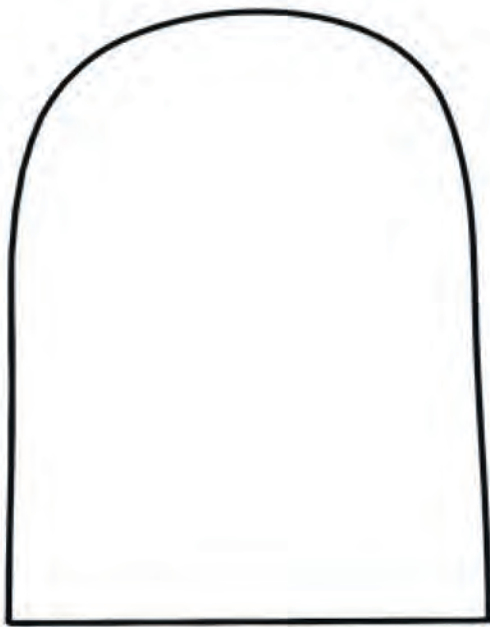

BACKGROUND
GREEN
CUT 2



SCROLL
WHITE

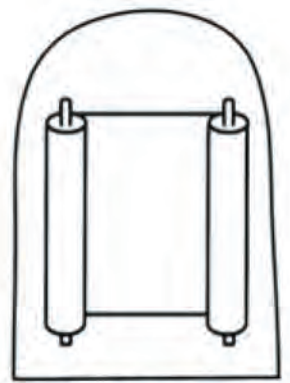

**TORAH
SCROLL**

TEMPLATE FOR
FELT PUPPET

Craft Template A (BW)

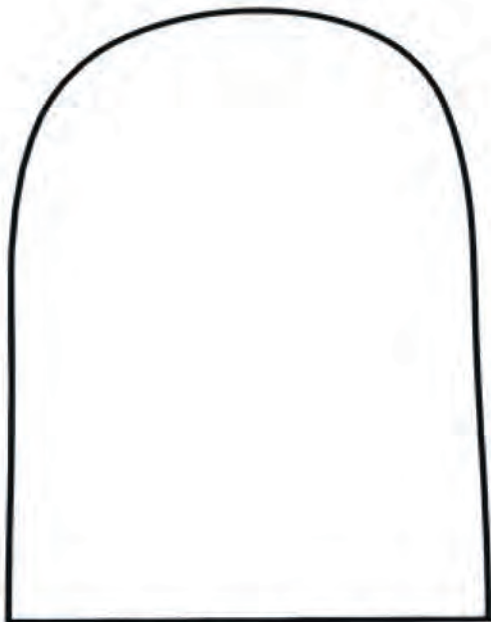

BACKGROUND
RED
CUT 2



SHOFAR
TAN

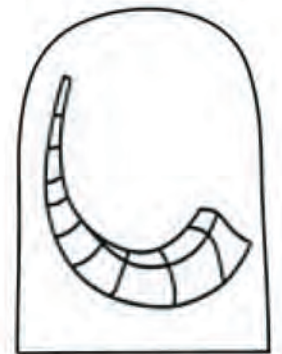

SHOFAR

TEMPLATE FOR
FELT PUPPET

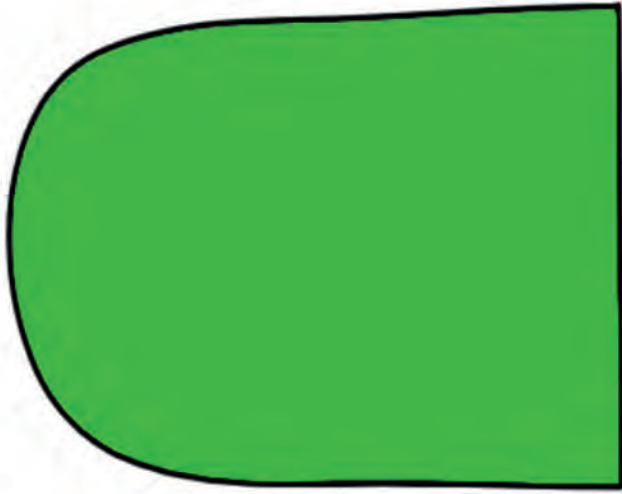

BACKGROUND FRONT

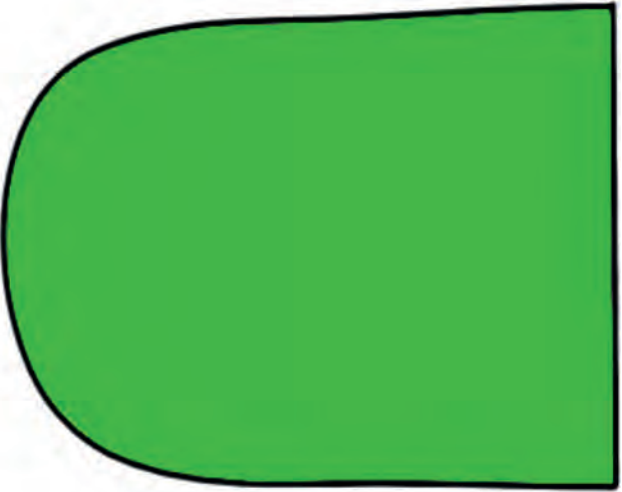

BACKGROUND BACK



TORAH SCROLL

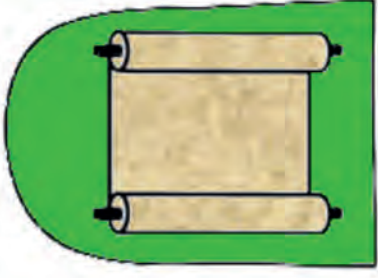

TORAH

SCROLL

TEMPLATE FOR
STICK PUPPET

Craft Template B (color)

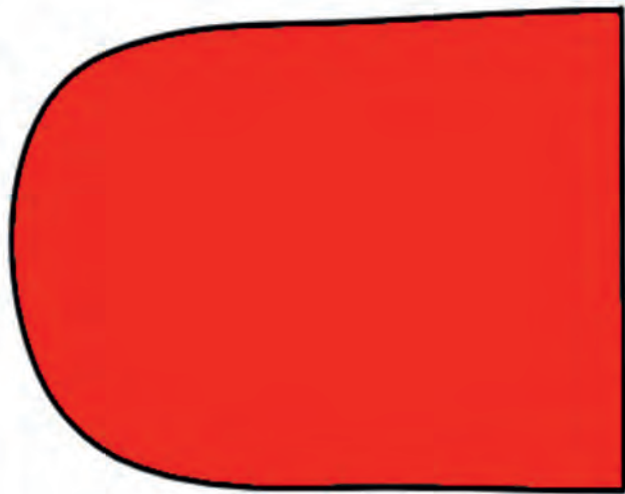

BACKGROUND FRONT

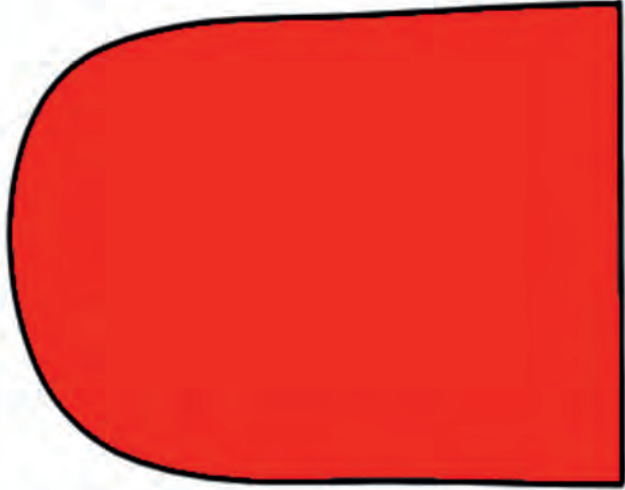

BACKGROUND BACK

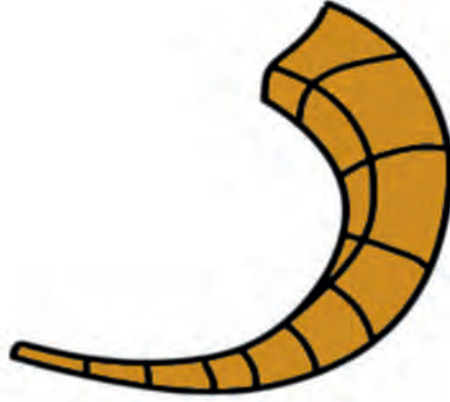

SHOFAR

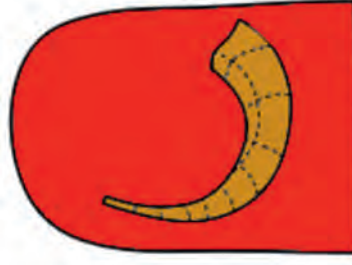

SHOFAR

TEMPLATE FOR
STICK PUPPET

Zichron Teruah

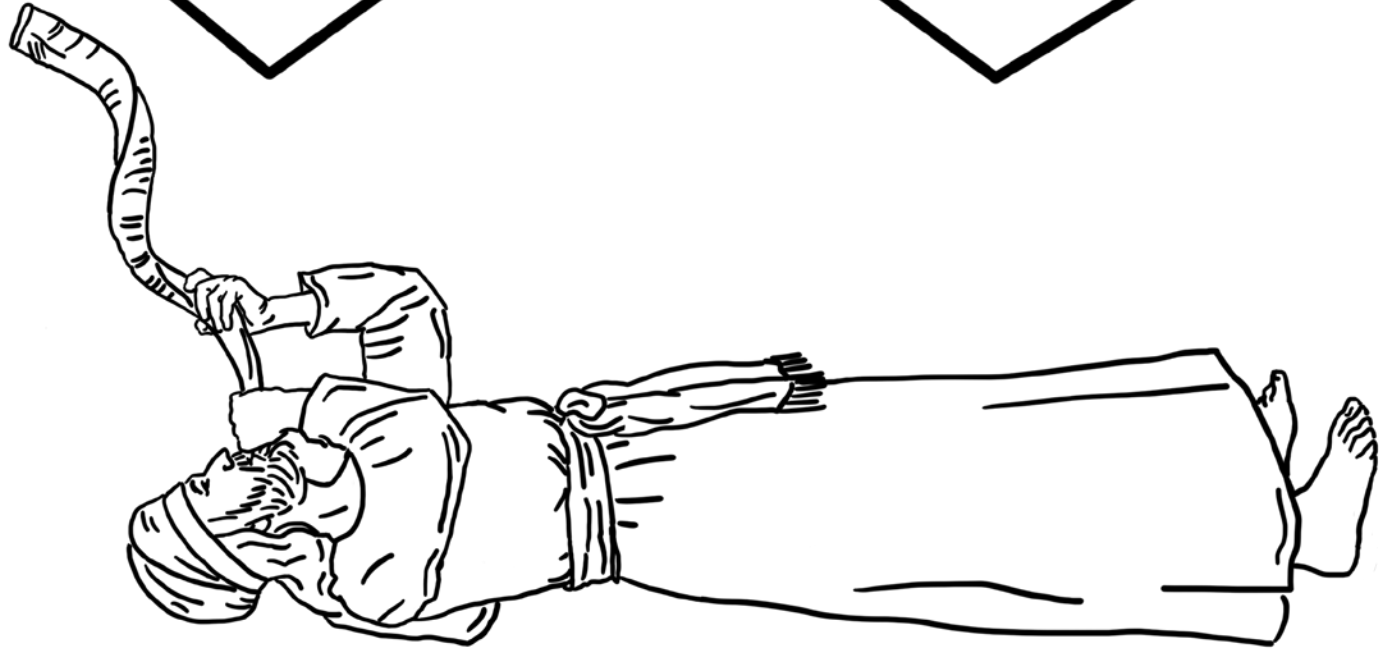

Yom Teruah

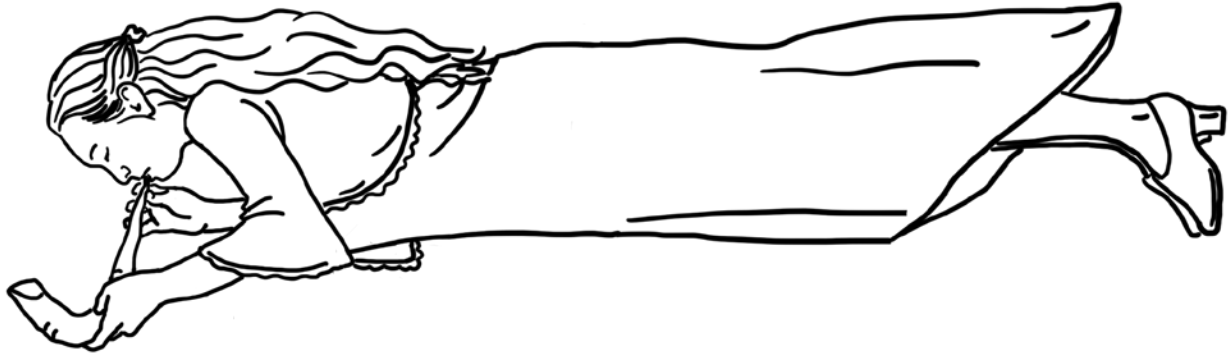
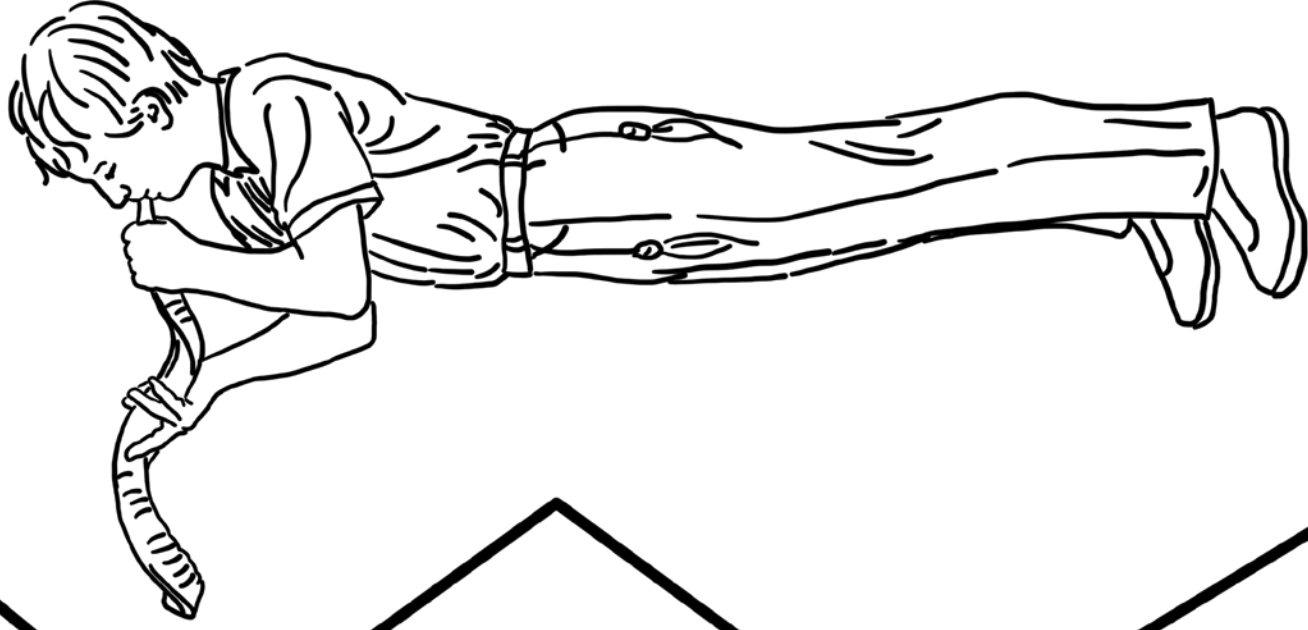

Sweetness of Torah

SWEET SOUNDS OF TORAH

(Sing Praises to His Name)

Here is the link for this song:

https://www.podomatic.com/podcasts/steveberkson/episodes/2018-09-05T04_56_09-07_00

Sing to tune of "Oh my Darling Clementine"

Dip the Apple in the Honey

Shana Tovah U' Metuka means a 'good and sweet year'

Dip the apple in the Honey
Make a Bracha loud and clear
L' Shana Tovah U' Metuka
Have a Happy Sweet New Year!

Father, Mother, Sister, Brother
Gather round the table here
L' Shana Tovah U' Metuka
Have a Happy Sweet New Year!



SWEET TASTE OF TORAH

This snack relates to this week's lesson. Please take these as suggestions and make necessary changes based on your individual dietary needs.

Waffle Cone Trumpet

Leviticus 23:24; Numbers 29:1



Ingredients:

- Waffle cone
- *Magic Shell* chocolate topping (to cover edges of cone)
- White round candy melts (represents trumpet finger buttons)
- Sprinkles (color of choice)
- Various fruits (of choice)

Instructions:

Squeeze *Magic Shell* topping all around the opening edge of a waffle cone. Place sprinkles of choice onto a dish and dip the chocolate covered cone into sprinkles making sure to cover the edges of the horn. Dip the white candy melts into *Magic Shell* to use as adhesive for the cone. Place 3-4 round candy melts on the waffle cone in a line and place in freezer to harden for a few seconds. Remove waffle cone from freezer and fill with fruit. Apples are the tradition for this day but you can use whatever you prefer.

SWEET TASTE OF TORAH

This snack relates to this week's lesson. Please take these as suggestions and make necessary changes based on your individual dietary needs.

Honey Fruit Cup



Ingredients:

- 1 (6 oz.) container lemon, custard style yogurt
- 1 (3 oz.) pkg. cream cheese, softened
- 1 Tbsp. honey
- 2 med. apples, sliced
- 2 med. pears, sliced

Instructions:

Use a food processor or blender to combine yogurt, cream cheese and honey. Process until smooth. Put apple and pear slices in bowl and cover with mixture from processor. Makes 2 (1/2 cup) servings.

You can find this and other recipes in the MTOI Ladies Ministry 2nd Edition Cookbook which gives recipes for each of the feasts. By following this [link](#) you can order your own copy of this fantastic cookbook with a collection of recipes from MTOI participants.